

BD 10/10 M4 0,59kW (251320260)

GENERAL DATA



FAN DOUBLE INLET

MANUFACTURING FEATURES:

- Galvanised steel sheet housing.
- Polyamide impeller reinforced with fibreglass in models 7/7, 9/9, 10/10 and 12/12. The impeller of the rest of models are made of galvanised steel sheet.
- Double inlet forward curved impeller in all models.
- Supplied with mounting feet (included in price). Except 15/15 which is a cubic model.
- Exclusive system Casals fixing motor and turbine fan by flexible arms silent blocks to avoid any vibration. Arms in compliance with ROHS regulations 2002/95 / EC (Restriction of Hazardous Substances in electrical and electronic equipment)
- Closed motors specially designed Casals: extruded aluminum housing, all protected inside the terminal box on the motor IP 65 protection and motor with IP54 protection and Class F insulation standard voltages: 230V 50Hz in single phase and 230/400V 50Hz three-phase.
- Single phase motors with controllable voltage speed. Three phase motors controllable using a frequency speed controller

APPLICATIONS:

Designed for assembly in equipment:

- Ventilation boxes and air handling units.
- Centrifugal heaters.
- Industrial and professional kitchen hoods.
- Maximum working temperature: 50°C for single phase motors and 60°C for three phase motors.

UNDER REQUEST

- Impeller made of galvanized steel sheet.
- MBI assembled

PERFORMANCE CURVE

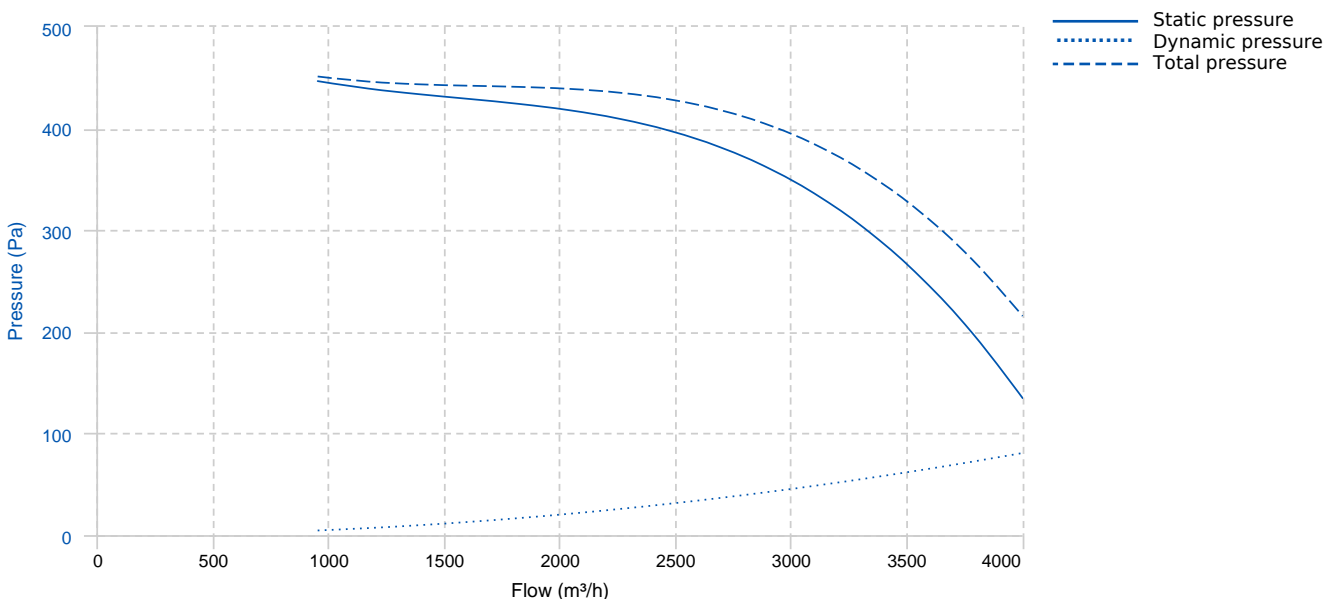

TECHNICAL DATA

Fan							
RPM	1340	Approx. weight	22 kg	Max. Flow	4010 m ³ /h		
Motor							
Power	0,59 kW	RPM	1340	Capacitor	28μF 400V	I max. (230V)	4,5 A
Size	STC80	Approx. weight	7.7 kg	Efficiency (%)	68 %	FP	0.96

ERP DATA

Fan data sheet		
Fan type	Centrifugal fan radial or forward blades	
Installation category	A: Outlet and Inlet free discharge	
Efficiency category	Static	
The fan has to be installed with VF	No	
Motor power (kW)	0.59	
	Fan values	ERP Requirements 2015
Max. efficiency (%)	38.41	36.8
Efficiency grade (N)	45.62	44
Pabs (kW)	0.727	
Flow (m ³ /h)	2454.37	
Static pressure (Pa)	399.11	
Speed (m/s)	1340	
Specific ratio	1.00	

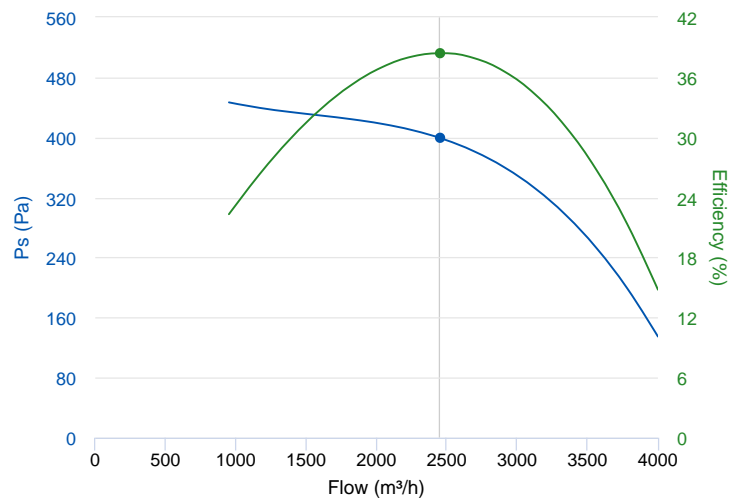

DIMENSIONS

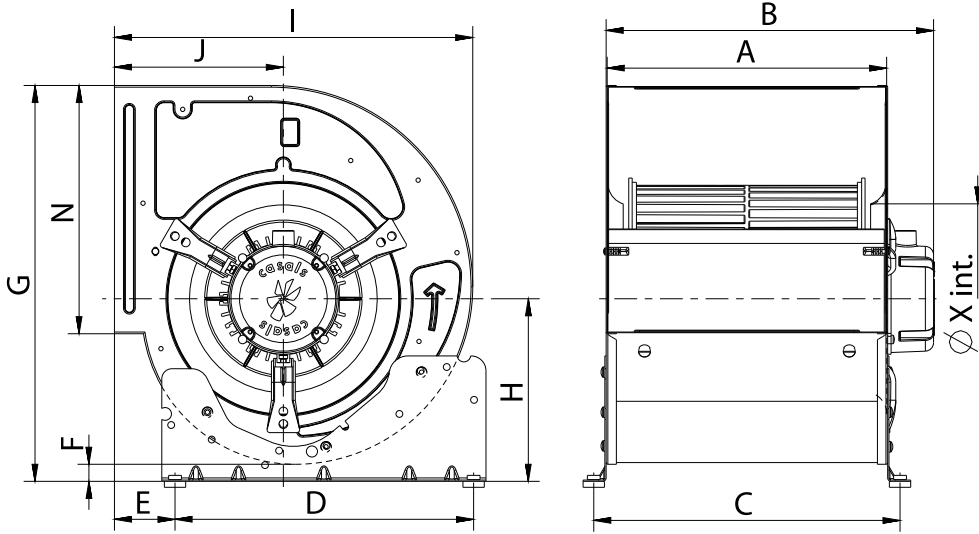

Dimensions (mm)									
A	329	B m ^à x	384	C	359	D	350	E	70,5
F	20	G	464	H	214	I	420	J	198
N	291	X	220						

WIRING DIAGRAM

SINGLE PHASE MOTOR MOTOR MONOFÁSICO

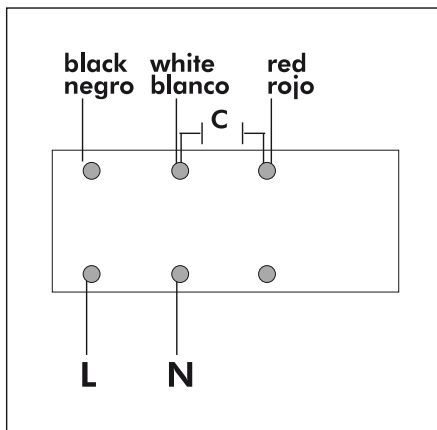

ACCESSORIES



**MANUAL SINGLE PHASE SPEED CONTROLLER
REG 5A**
REF: 960710050



**SAFETY SWITCH
INT 25 3P A**
REF: INT253PA



**OUTLET PROTECTION GUARD FOR FANS
RI 10/10**
REF: 960000406



**PROTECTION GRID FOR BD FANS, MOTOR SIDE
RM 10 (T80)**
REF: 960000804



**INLET PROTECTION GUARD FOR CENTRIFUGAL
FANS
RA 10**
REF: 960650100



**OUTLET FLANGE FOR BD AND BV FANS
MBI 10/10**
REF: 251371691

SPARE PARTS

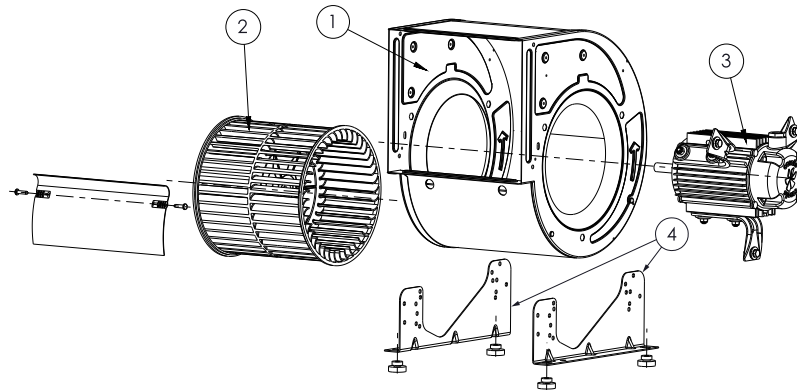

	Code	Model	Qty
1	R-251379421	CASING BD10/10	x1
2	R-251379383	TURBINE PA6 BD10/10	x1
3	251329478	MOTOR+SUPPORTS BD10/10M4 STC	x1
3	720331145	MOTOR BD M4 0,59kW 230V	x1
4	960520100	MOUNTING SUPPORT S 10	x1