

BT-3 250 (509825000)

GENERAL DATA

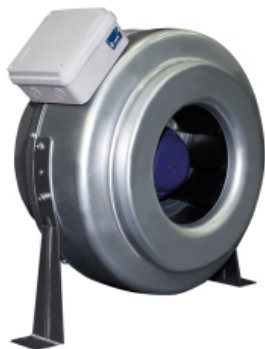

CENTRIFUGAL IN LINE WITH EXTERNAL ROTOR MOTOR

MANUFACTURING FEATURES:

- Housing in galvanized sheet.
- Backward impeller dynamically balanced.
- External connection box.
- Single-phase asynchronous motor with external rotor, including thermal protector for automatic resetting and long-life permanent lubrication ball bearings (40,000 hours). Protection IP-44. Standard voltage 230V 50/60Hz (except 315 size which has different motor at 50Hz than 60Hz)
- Supplied with support feet (optional mounting)

APPLICATIONS:

Designed for duct installation, suitable for false ceiling, are indicated for:

- Renovation of air in bathrooms and small rooms.
- Maximum continuous working temperature: 50°C.
- Fan not suitable for transporting explosive gases.

PERFORMANCE CURVE

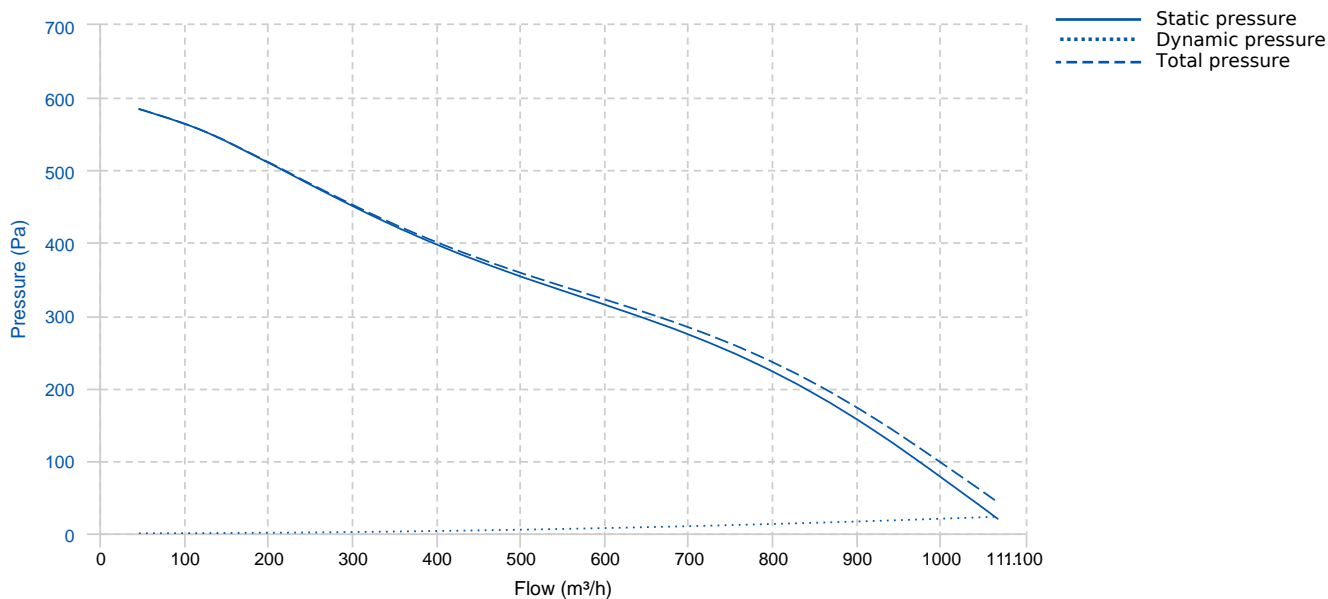

TECHNICAL DATA

Fan					
RPM	2765	Approx. weight	5.25 kg	Max. Flow	1070 m³/h
Motor					
Power	0,152 kW	RPM	2765	I max. (230V)	0,66 A

ERP DATA

Fan data sheet		
Fan type	Unit for non-residential ventilation (LOT 6)	
Typology	Unidirectional	
reports.other	None	
Type of driver	None	
Motor power (kW)	0.152	
	Fan values	ERP Requirements 2018
Max. efficiency (%)	36.97	30.18
Effic. Heat recovery (%)	-	
Pabs (kW)	0.149	
Flow (m³/h)	586	
Static pressure (Pa)	320.15	
Speed (m/s)	3.4	
SFP (W/m3/s)	912.84	

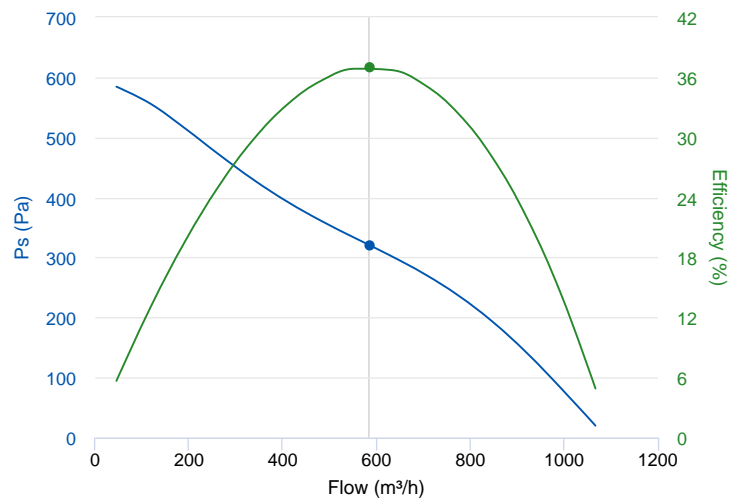

DIMENSIONS

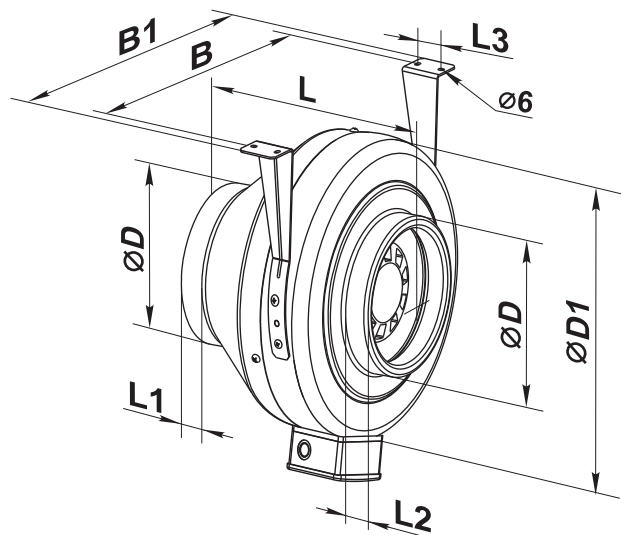

Dimensions (mm)									
B	340	B1	380	L	213	L1	25	L2	29
L3	40	ØD	249	ØD1	332				

WIRING DIAGRAM

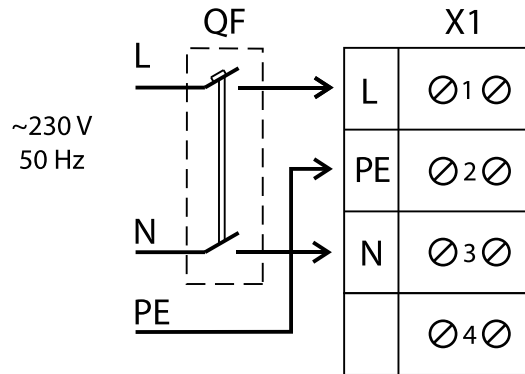

ACCESSORIES



MANUAL SINGLE PHASE SPEED CONTROLLER
REG 1,5A
REF: 960710015



SAFETY SWITCH
INT 25 3P A
REF: INT253PA



ANTI-VIBRATION JOINT
JE 45
REF: 300719201



MANUAL SINGLE PHASE SPEED CONTROLLER
REGD-1
REF: 300782600



CIRCULAR SOUND ATTENUATOR IN GALVANISED
STEEL
SILC-MINI 250
REF: SILCM250