



The Cooling Tower Collection Quality - Efficiency - Hygiene



JACIR



DECSA



GOHL-KTK

Cooling for life

JACIR S.A.S. DECSA SRL GOHL-KTK GMBH



QUALITY – EFFICIENCY – HYGIENE

- ▶ For more than half a century, the brands JACIR, DECSA, GOHL and KTK have been synonymous with innovative cooling tower technologies.

Under the umbrella of COFINAIR Group, they bring together experience and expertise in the development and manufacturing of high quality cooling towers.





JACIR

140 people in France

GOHL-KTK

115 people in Germany

DECSA

45 people in Italy

4 Lean manufacturing production sites
for a total surface of **45 000 m²**



105

Qualified skilled production workers,
including method and industrialisation
Engineers, Certified welders, qualified
technicians and engine operators

45

Draughtsmen in the Technical office
dedicated to design and 3D modeling



THE LARGEST EUROPEAN PRODUCT RANGE

DIVERSITY OF COOLING TOWER PROJECTS

Our extremely wide product line and decades of experience allow us to find the right solution for each of our customers. In fact, our systems are already used in nearly all fields of building climate control and industrial process cooling.

COMMITTED TO THE CUSTOMER BENEFIT

HYGIENE

All of our system-based solutions are designed and constructed to meet the highest statutory directives and requirements. We support you from the first consultative discussion and up to delivery of comprehensive services, so you get complete solutions from one dependable source.

QUALITY & ENVIRONMENT

Sustainability is one of the pillars of our corporate philosophy. We strive for quality and longevity in both our products and business relationships. Environmentally-friendly use of resources and energy plays a central role in the development of our new technology innovations.

EFFICIENCY

Aside from performance, efficiency is one of the top factors in any investment decision. Low operating costs and very lower service expenses are deciding parameters.



Decsa pays special attention to its R&D activities. A dedicated team of engineers continuously tests and develops new solutions in the evaporating cooling and thermal exchange field, to be applied to our machine range of products : acoustic & performance tests

GUARANTEED PERFORMANCE

The quality we deliver is based on many years of experience and verified by specific certifications. We've done the hard work already! Take advantage of our certifications from independent institutes.

EUROVENT AND CTI CERTIFICATION

COFINAIR Group brands participate in cooling towers performance ECC Program.

Thermal performance has been verified by thermodynamic calculations and independent tests on test stands performed by Eurovent-certified test Quality Management System.



Label of DTC Line

- CTI ▶ member + certification
- EUROVENT ▶ association + certification

EUROVENT CERTIFIED PRODUCT LINES ARE:

DTC - VAP - ZENIT - X-TAR

CTI CERTIFIED PRODUCT LINES ARE:

DTC - VAP - ZENIT - X-TAR - TMA-EU

**CHECK ONGOING VALIDITY OF CERTIFICATES:
WWW.EUROVENT-CERTIFICATION.COM OR WWW.CTI.COM**



CORROSION

The independent Institut für Korrosionsschutz Dresden GmbH has verified that the whirl sintering coating process meets the requirements of DIN EN ISO 12944 at the highest corrosion category C5-M.



The COFINAIR Group companies are **ISO 9001** certified : Quality Management System.



DECSA company is also **ISO 14001** & **ISO 45001**

- ▶ EAC - "EurAsian Economic Certification" certified.
- ▶ PED certification for coils – Directive 2014/68/EU Mod B
- ▶ PED certification for coils – Directive 2014/68/EU Mod D



JACIR production facilities is **MASE-UIC** certified.

CONTENTS

MATERIALS	Page 10
PRODUCTS RANGES	
▶ Open-Circuit - Counter Flow Cooling Towers	Page 12
▶ Open-Circuit - Cross Flow Cooling Towers	Page 20
▶ Closed-Circuit Cooling Towers	Page 22
▶ Hybrid Cooling Towers	Page 28
▶ Heavy Duty	Page 32
▶ Adiabatic Coolers & Condensers	Page 36
▶ Evaporative Condensers	Page 42
SERVICES	Page 46
REFERENCES	Page 54

MATERIALS

- ▶ Cooling towers are frequently subject to extreme weather conditions and must therefore be constructed of corrosion and weather-resistant materials. Whether you choose X-STEEL, DecsaCOATING Plus or Whirl-sintering, you can be confident in the durability of our towers.

CASING AND INFILLS

Range of cooling towers aesthetically designed for ease of maintenance : design and material selection ensures good performance, long life and safe, easy cleaning.

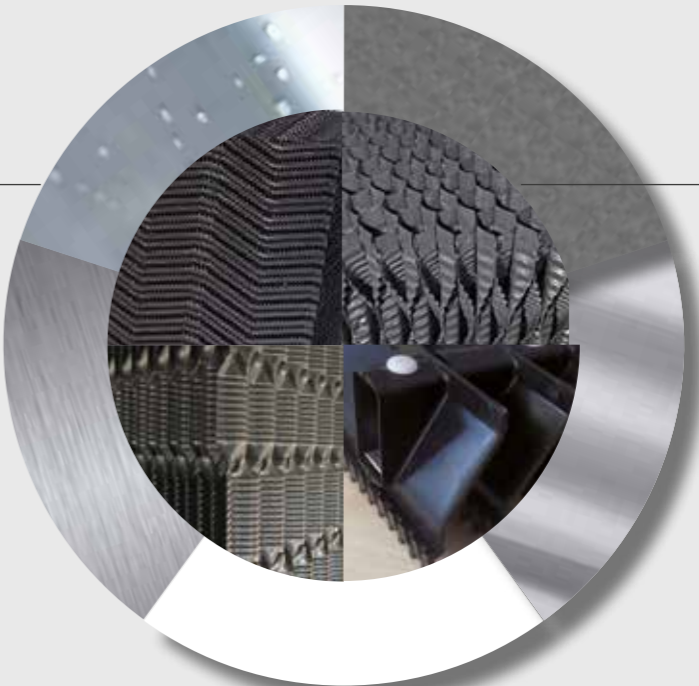
CASING options		INFILL options
X-Steel		X-Stream
—		—
Whirl-sintering		DecsaPACK
—		—
DecsaCOATING		Freefilm
—		—
FRP		Effi-Pack
—		—
Silver Steel		X-Pack
—		—
Galvanized steel		PP 12mm
		PP 19mm

SILVER-STEEL : manufactured on a classic hot dip galvanized steel production line, and the dipped into a fusion bath of specific chemical zinc composition which is enriched of aluminum and magnesium. 5 years non perforation warranty.

X-STEEL stainless steel characterised by mechanical and chemical resistance to corrosion higher than those of 316 L stainless steel, Its smooth surface slows bio film growth and avoids galvanisation 's loss which is a pollutant once diluted in the water (harmfull pollutant as soon as diluted in discharge water - zinc). 10 years non perforation warranty.

DecsaCOATING Plus provides a high level of protection of galvanized sheet powder coating : leading to reduction of water consumption thanks to higher cycles of concentration than running in HDGS Z725, and consequently lower environmental impact.

Whirl sintering is a 0,3mm termoplastic coating for cooling towers of brand GOHL which stands for extremely long operating cycle. It is C5-M certified, the highest corrosion category in accordance to coastal and offshore areas with high salt pollution (DIN 55633 und DIN EN ISO 12944).

Others available materials : [Galvanized Steel](#) - [FRP](#) - [Concrete](#)

OPEN CIRCUIT COOLING TOWERS FOR CLEAN WATER

OPEN COOLING TOWERS HAVE
THE HIGHEST POWER DENSITY

- ▶ They are used wherever cooling machines require large volumes of water and/or when cooling water must be at a low temperature. Open-circuit towers do not have special requirements for water quality.

The most efficient method of cooling



COUNTER FLOW - OPEN CIRCUIT COOLING TOWERS CENTRIFUGAL FORCED-DRAFT FANS

- ▶ Pressure-ventilated evaporative cooling towers with centrifugal fans are highly flexible and have a relatively small footprint. Forward curving vanes on the fan impeller allow the fan to work at low speed. The significant pressure reserves allow attachment of additional sound absorbers on the unit.

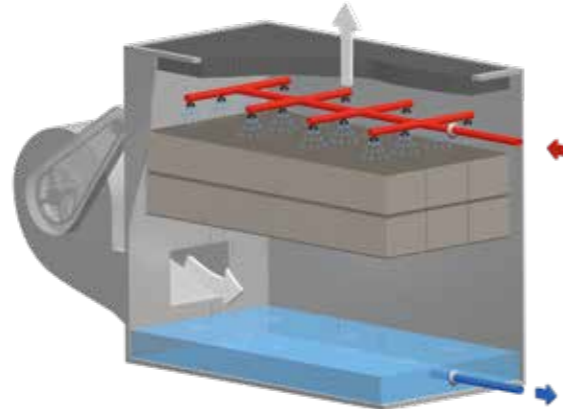

Series of centrifugal cooling towers S /KS /ERD /WRD /TMR

Forced-draft evaporative cooling towers for open-circuits, with side-mounted centrifugal fans, for indoor and outdoor installation.

BENEFITS

- ▶ Low noise values
- ▶ Robustness
- ▶ High efficiency
- ▶ Low investment
- ▶ Maintenance & Hygiene
- ▶ Compact for transport



HYGIENE & TECHNICAL FEATURES

- ▶ Water basin bottom inclined towards the drain
- ▶ Hygiene-optimized water inlets and outlets
- ▶ Variable height - higher cooling capacity with the same surface area

COUNTER FLOW - OPEN COOLING TOWERS AXIAL FORCED-DRAFT FANS

Series of axial forced-draft cooling towers KH

Induced-draft cooling tower with axial fan, for outdoor installation.

BENEFITS

- ▶ Low power consumption
- ▶ Motor fan outside the wet air flow
- ▶ Easy motor and fan access

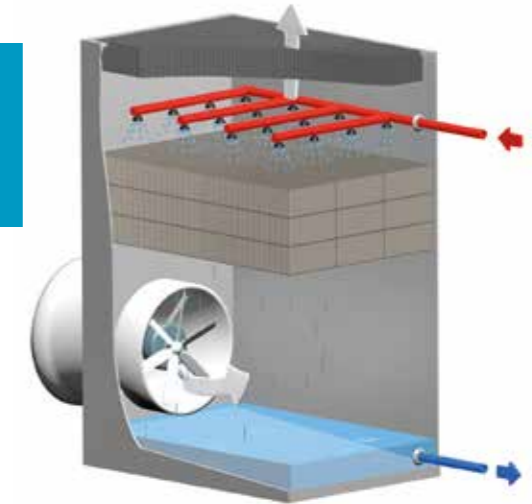

- ▶ Pressure-ventilated evaporative cooling towers with helicoidal fan are highly flexible and have mechanical strength to match the industrial applications needs. Specially designed based on accessibility to all internals for an easy maintenance.



COUNTER FLOW - OPEN CIRCUIT COOLING TOWERS AXIAL INDUCED-DRAFT FAN

Series of axial fan cooling tower TMA-EU

Induced-draft evaporative cooling towers for open-circuits, with axial fan, for indoor and outdoor installation.

- ▶ Suitable for industrial applications in many fields like plastic, chemical, pharmaceutical, automotive, energy production and air conditioning for hospital, commercial buildings...

BENEFITS

- ▶ Low maintenance costs
- ▶ Robustness
- ▶ High efficiency
- ▶ Maintenance & Hygiene
- ▶ Compact for transport



HYGIENE & TECHNICAL FEATURES

- ▶ Waterbasin anti legionella design
- ▶ Hygiene-optimized and easy maintenance spare parts
- ▶ Low energy consumption motor

Series of axial fan technology cooling towers SQA

Induced-draft evaporative cooling towers equipped with AC fans, with permanent magnet variant, easy maintenance oriented design, for indoor and outdoor installation.

BENEFITS

- ▶ Best ratio heat rejection / overall dimensions
- ▶ Extended fill packs: 19 mm, splash
- ▶ High energy saving
- ▶ Operational flexibility
- ▶ Quick and easy maintenance
- ▶ Reduced transportation costs

- ▶ Suitable for industrial applications with water even partially contaminated with suspended solids



Series of axial induced-draft VAP

Induced-draft cooling tower with axial fan FRP for outdoor installation.

- ▶ Open-circuit axial induced-draft cooling towers have the highest power density. The straightforward design and small footprint, making it suitable for virtually all industrial cooling tasks. High-performance axial fans are characterized by very low power needs. This keeps power consumption and operating costs low.

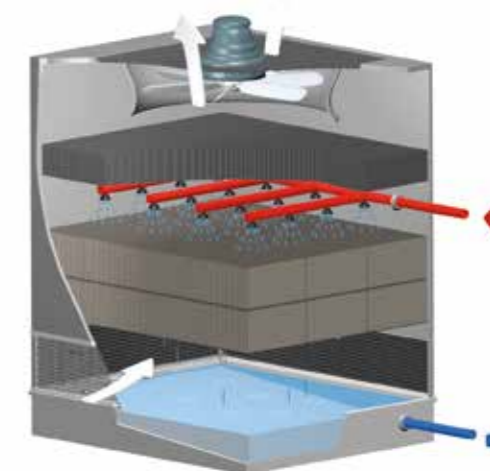

- ▶ NON-corrodible tower casing for parts in contact with water
- ▶ Very compact, delivered in a single piece (according range type) for a simple and quick installation on site
- ▶ Direct drive single fan = long lasting and mechanical reliability
- ▶ Large access door for easy and complete maintenance



EUROVENT AND CTI CERTIFICATION

The wet cooling tower line VAP IS based on the latest calculation methods in the thermodynamic power configuration. Energy consumption and cooling capacity are confirmed by EUROVENT and CTI.

CHECK ONGOING VALIDITY OF CERTIFICATES:

WWW.EUROVENT-CERTIFICATION.COM OR WWW.CTI.COM

COUNTER FLOW - OPEN COOLING TOWERS MAINTENANCE-FREE EC FORCED-DRAFT FANS

- ▶ The innovative, service-optimized design of DTC merges the benefits of indispensable wet cooling towers with economical operation and elevated requirements for hygiene.

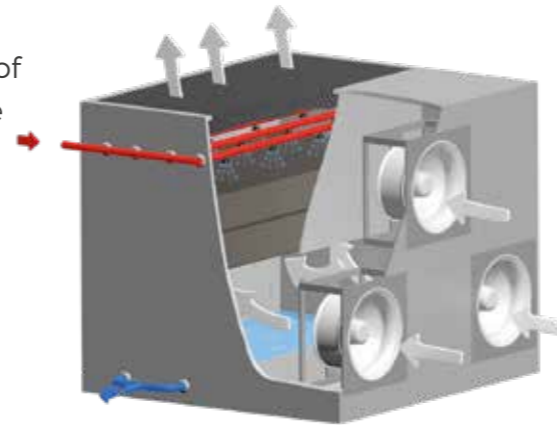

Series of EC-Fans technology cooling towers DTC

Forced-draft evaporative cooling towers equipped with EC fans, easy maintenance oriented design, for indoor and outdoor installation.

BENEFITS

- ▶ 30% energy savings
- ▶ Very low noise
- ▶ Sustainably low operating costs
- ▶ Maintenance-free EC fans
- ▶ Large access opening for service and maintenance
- ▶ Best hygienic conditions



EASY MAINTENANCE

- ▶ "Walk-In" System
- ▶ Maintenance free EC-fans
- ▶ Reduction of components

EC FANS TECHNOLOGY

- ▶ Ecodesign (EU) 327/2011 compliant technology for the application of Directive 2009/125/EC (ErP) for minimum efficiency thresholds after 202x.
- ▶ New compact quiet EC centrifugal motor-fans for more power and efficiency, whose EC motor is integrated directly into the wheel.
- ▶ Continuous control by electronic switching: efficiency significantly higher than the IE4 efficiency class, without any use of rare earth magnets.

COUNTER FLOW - OPEN COOLING TOWERS AXIAL INDUCED-DRAFT MAINTENANCE FREE EC-FANS

Series of EC fans induced-draft cooling towers ZENIT

Induced-draft cooling tower with EC-fans, for outdoor installation.

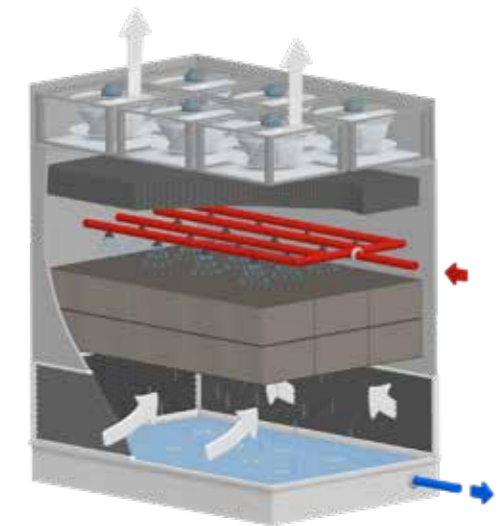

BENEFITS

- ▶ Low power consumption
- ▶ Mechanical reliability
- ▶ Easy maintenance and hygiene



EUROVENT AND CTI CERTIFICATION

The wet cooling tower lines DTC and ZENIT are based on the latest calculation methods in the thermodynamic power configuration. Energy consumption and cooling capacity are confirmed by EUROVENT and CTI.

CHECK ONGOING VALIDITY OF CERTIFICATES:
WWW.EUROVENT-CERTIFICATION.COM OR WWW.CTI.COM

CROSS FLOW - OPEN COOLING TOWERS INDUCED DRAFT MAINTENANCE FREE EC-FANS

Series of EC Fans induced draft cooling towers X-TAR

Induced-draft evaporative cooling towers equipped with EC fans, easy maintenance oriented design, for indoor and outdoor installation.

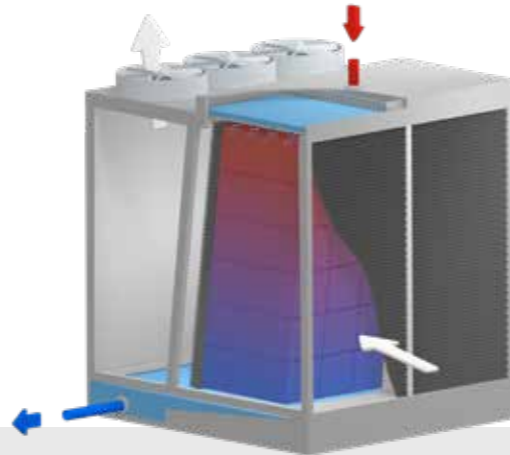

EC FANS TECHNOLOGY

- ▶ Ecodesign (EU) 327/2011 compliant technology for the application of Directive 2009/125/EC (ErP) for minimum efficiency thresholds after 202x.
- ▶ New compact quiet EC centrifugal motor-fans for more power and efficiency, whose EC motor is integrated directly into the wheel.
- ▶ Continuous control by electronic switching: efficiency significantly higher than the IE4 efficiency class, without any use of rare earth magnets.



BENEFITS

- ▶ X-PACK highly efficient Infill
- ▶ State-of-the-art EC motor technology Highly efficient, silent and low-carbon footprint
- ▶ Designed for easy and safety maintenance

EUROVENT AND CTI CERTIFICATION

The wet cooling tower line X-TAR is based on the latest calculation methods in the thermodynamic power configuration. Energy consumption and cooling capacity are confirmed by EUROVENT and CTI.

CHECK ONGOING VALIDITY OF CERTIFICATES:
WWW.EUROVENT-CERTIFICATION.COM OR WWW.CTI.COM

CROSS FLOW - OPEN COOLING TOWERS INDUCED DRAFT AC-FANS WITH PM VARIANT

Series of AC Fans induced draft cooling towers TM-X

Induced-draft evaporative cooling towers equipped with AC fans, with permanent magnet variant, easy maintenance oriented design, for indoor and outdoor installation.



BENEFITS

- ▶ DecsaPACK Infill providing highly efficient exchange surface
- ▶ Low pressure drop
- ▶ Reduced power consumption
- ▶ Reduced transportation costs



- ▶ Evaporative cooling towers with helicoidal fan are highly flexible and have mechanical strength to match the industrial applications needs. Specially designed based on accessibility to all internals for an easy maintenance.



CLOSED CIRCUIT COOLING TOWERS FOR CLEAN WATER

SAFE OPERATION

- ▶ Closed cooling towers are preferred particularly in situations with high requirements for cooling water quality, such as machines with narrow cooling channels.

COUNTER FLOW - CLOSED CIRCUIT COOLING TOWERS CENTRIFUGAL OR AXIAL FORCED-DRAFT FANS

- ▶ Water evaporative cooling tower, closed-type, is designed for a glycol-free operating during winter.
The closed cooling towers are fully factory assembled on a single frame and composed of a dismantlable and cleanable Plate Heat Exchanger, a pump and a filter with all technical accessories grouped together inside a closed room that is accessible through a large door for its maintenance.

Series of Closed circuit cooling towers SF / KSF / KHF

Centrifugal or axial Forced-draft fans - closed cooling towers for indoor and outdoor installation.

BENEFITS

- ▶ No freezing without glycol
- ▶ Low noise
- ▶ Easy maintenance

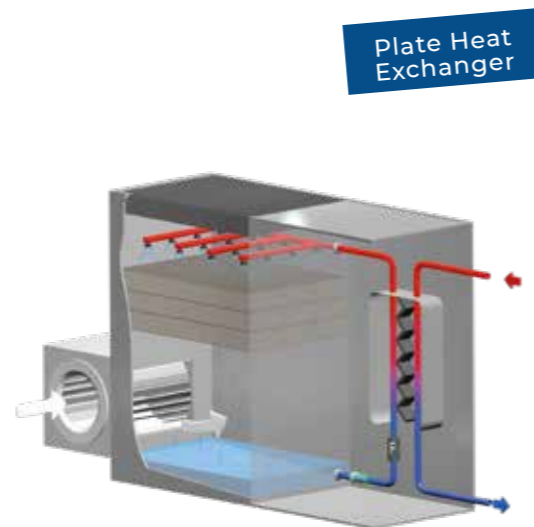

FRC centrifugal filter

In addition to the natural fouling resistance of the exchanger (high water velocity), this equipment is designed to retain and then remove suspended solids in the water that may offer nourishment for bacteriological growth. Automatic cleaning is realised during the blow-down by induction cycle or by timer, 100% filtering of the water flow at 60 µm efficiency.

patented



COUNTER FLOW - CLOSED CIRCUIT COOLING TOWERS AXIAL INDUCED-DRAFT FANS

Series of Closed circuit cooling towers VAPF

Axial Induced-draft fan - closed cooling towers, for outdoor installation.

- ▶ Supplied on its frame, the plate heat exchanger does not require any anti-freeze protection: in case of electrical stop, the water-cooling tower circuit automatically drains by gravity down the basin, protecting by the way plates and gaskets of the exchanger. Also equipped with its pump, pressure meters and FRC centrifugal filter (JACIR patent) for complete clean circuit.

BENEFITS

- ▶ No freezing without glycol
- ▶ Full cleaning on primary & secondary circuits

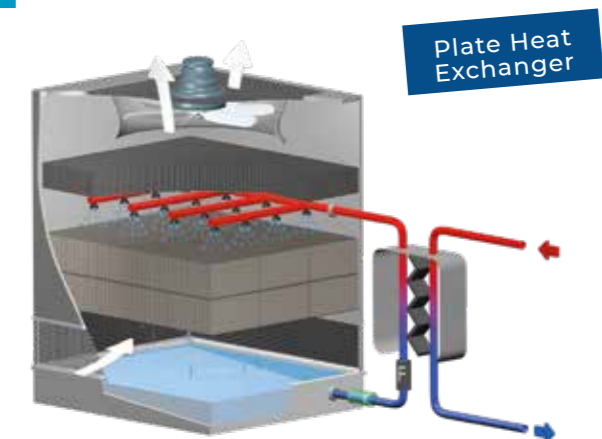

- ▶ Exceptional lifetime
- ▶ Simplified maintenance
- ▶ Complete disassembly and cleaning
- ▶ Direct coupling fan/motor

COUNTER FLOW - CLOSED CIRCUIT COOLING TOWERS CENTRIFUGAL FORCED-DRAFT FANS

- ▶ Water evaporative cooling tower, closed-type equipped with a hot dip galvanised carbon steel tube coil heat exchanger.

Series of Closed circuit cooling towers REF-C

Centrifugal Forced-draft fans - closed cooling towers, for indoor and outdoor installation.



BENEFITS

- ▶ Wide range of heat rejection capacities
- ▶ Low noise
- ▶ Easy maintenance
- ▶ Economical transportation



Tube coil Heat Exchanger

COUNTER FLOW - CLOSED CIRCUIT COOLING TOWERS AXIAL INDUCED-DRAFT FAN

Series of Closed circuit cooling towers REF-A

Axial Induced-draft fan - closed cooling towers for outdoor installation.



BENEFITS

- ▶ Wide range of heat rejection capacities
- ▶ Best ratio heat rejection / overall dimensions
- ▶ Low power consumption
- ▶ Easy maintenance
- ▶ Economical transportation

- ▶ REF-A series is designed and made to meet all applications where high efficiency and low operating costs evaporative coolers are required. The REF-A series is best integrated in systems where low noise and reliability are a fundamental point in the selection of equipment.



Tube coil Heat Exchanger



HYBRID COOLING TOWERS FOR CLEAN WATER

PLUMELESS COIL - HYBRID TECHNOLOGY

- ▶ Unique on the market, this technology prevents plume, even during low temperatures and reduces water consumption and its associated water treatment.

**COUNTER FLOW - OPEN HYBRID COOLING TOWERS
CENTRIFUGAL OR AXIAL FORCED-DRAFT FANS**

Series of Hybrid Coolers SIM / KSIM / KHIM

Forced-draft open Hybrid Coolers,
for outdoor installation

BENEFITS

- ▶ No plume, until 2°C ambient and 80% relative humidity,
- ▶ Water savings till 30 % over a year,
- ▶ Water treatment savings,
- ▶ Additional mechanical obstacle to drift : decrease of Legionella risk,
- ▶ The air drying reduces the drift propagation distance,
- ▶ High resistance to strong winter and maintenance conditions.

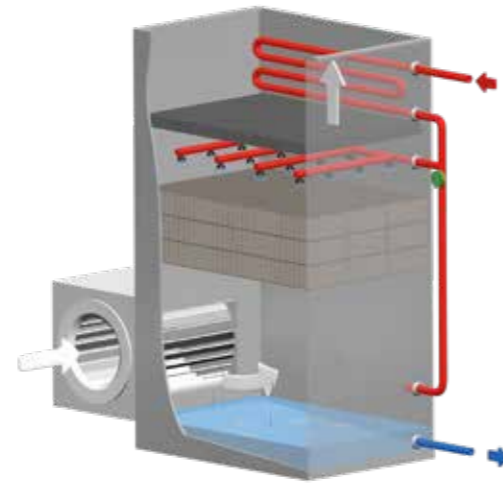

Patented

PLUMELESS COIL - HYBRID TECHNOLOGY

- ▶ Water distribution is regulated through a by-pass modulation valve
- ▶ Glycol free
- ▶ Warming and drying of the air, combined with reduced air moisture content from the packing, lead to complete plume suppression, even in severe weather conditions

**COUNTER FLOW - CLOSED HYBRID COOLING TOWERS
CENTRIFUGAL OR AXIAL FORCED-DRAFT FANS**

Series of Closed circuit Hybrid Coolers SFIM / KSFIM / KHIFIM

Centrifugal or axial Forced-draft fans Closed-Hybrid Coolers
for indoor and outdoor installation.

- ▶ Water evaporative cooling tower, closed-type, is designed for a glycol-free operating during winter.
The closed cooling towers are fully factory assembled on a single frame and composed of a dismantlable and cleanable Plate Heat Exchanger, a pump and a filter with all technical accessories grouped together inside a closed room that is accessible through a large door for its maintenance.

BENEFITS

- ▶ Glycol free
- ▶ Safe
- ▶ Easy maintenance

Plate Heat Exchanger

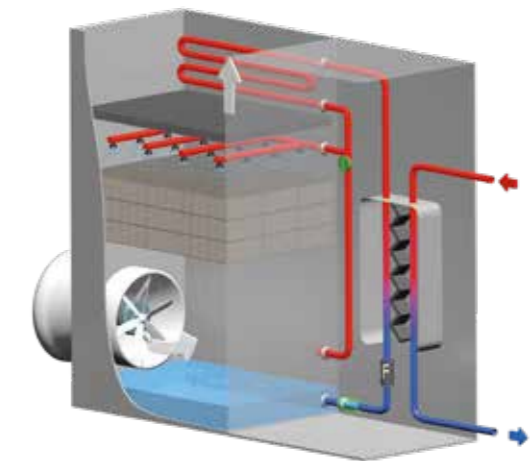

HEAVY DUTY

EXTREM CONDITIONS

- ▶ Cooling towers designed for extreme conditions of air and water. Highly polluted air and water with a high concentration of suspended particles are no longer a problem.



X-STREAM - COMPONENTS FOR EXTREME CONDITIONS OF AIR AND WATER

BENEFITS

- ▶ Very high resistance to clogging
- ▶ Very high mechanical resistance: 30 Kg/m²
- ▶ Highly simplified access for cleaning and maintenance
- ▶ For water up to 400 ppm suspended solids

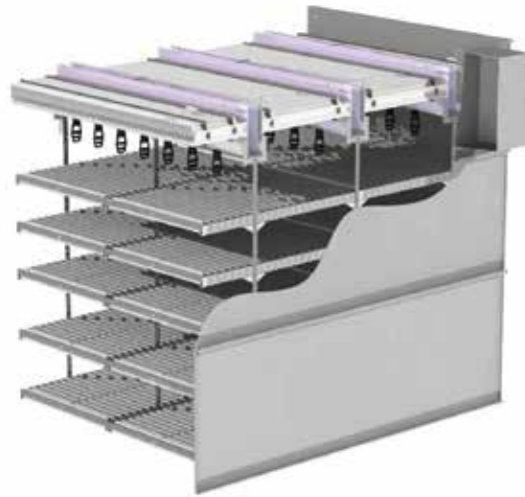

EXCHANGE SURFACE

Made of polypropylene vanes, they distribute the water along the fins, which then falls as drops onto the next lowest fin. The water cools and as it falls from one fin to another, so these drop formation bodies are extremely insensitive to clogging. They can be used for water with a solids content of up to 400 ppm. When using water with a high salt content, thermal expansion makes the **X-STREAM** drop formation bodies self-cleaning.

WATER DISTRIBUTION

Water is distributed using **X-steel** troughs that are equipped with polypropylene nozzles for optimal distribution across the entire air cross-section. These nozzles are designed with a large diameter to avoid clogging even with large amounts of suspended materials. Pressure losses are low (0 to 0.3 m WC) for low pump capacities and large drop formation keeps the water from escaping the tower. The distribution channels are designed to permit high performance even as the volume of water fluctuates greatly. The nozzles can be operated over a range of water volumes.



X-Stream Series for Axial-fans Forced-draft cooling towers **RH**

- ▶ high capacity & efficiency

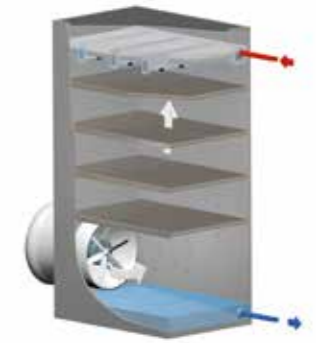

X-Stream Series for centrifugal fans forced-draft cooling towers **RC**

- ▶ low noise

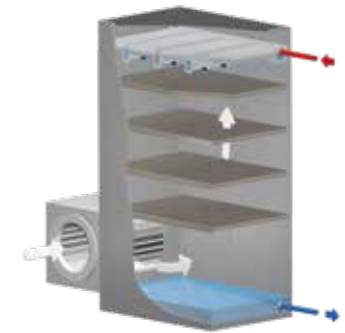

EASY MAINTENANCE

CLEANING WITHOUT DISASSEMBLY

- ▶ internal ladders with walkways (optional)
- ▶ multiple and large access doors
- ▶ X-Tract (optional)

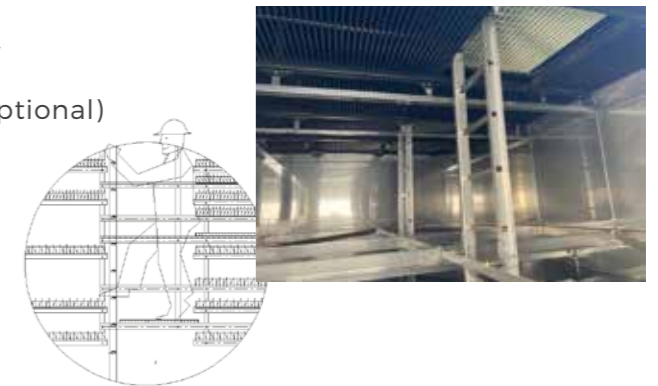

X-TRACT

Simplified installation and maintenance

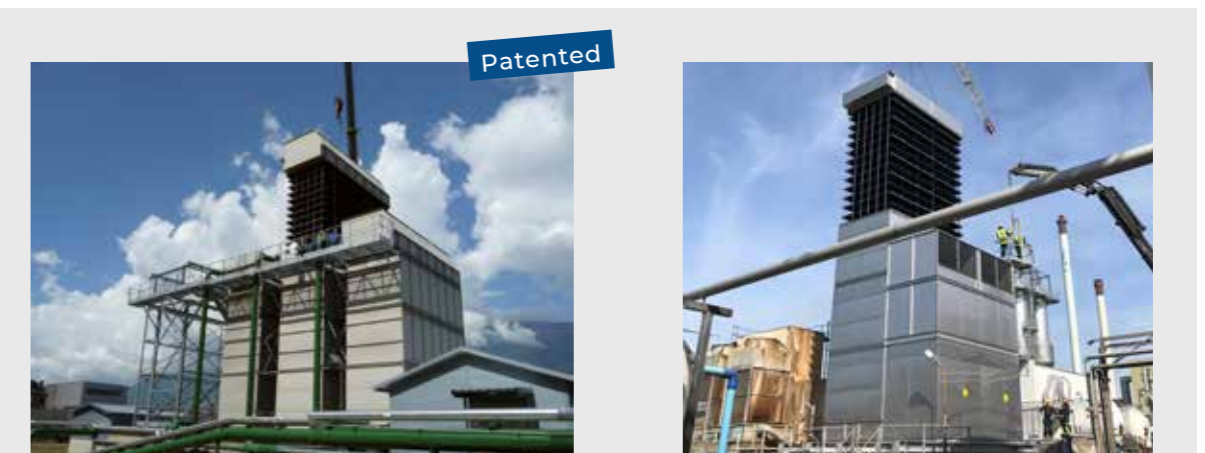

X-Tract System has been specially designed to simplify installation and maintenance operations. In a single lift, exchange surface, water distribution and drift eliminators are integrally removed allowing then a complete cleaning of the internals and of the casing on the ground.

ADIABATIC COOLERS & CONDENSERS

Legionella free

ADIABATIC RANGES ARE UNITS WHERE THE HEAT EXCHANGER REMAINS DRY.

- ▶ The Adiabatic range is a heat exchanger. Calories are released dry to the atmosphere. As soon as the climatic conditions get warmer, this exchanger uses the evaporation of water. So, safely and without water treatment, it dissipates the calories by maintaining a cold-water or condensing temperature lower than that of ambient air.

This adiabatic system results from the combination of a dry or condenser air cooler and an adiabatic pre-cooling section: this pre-cooling section lowers the ambient air temperature by evaporating water on humidifying pads designed specifically for this purpose.

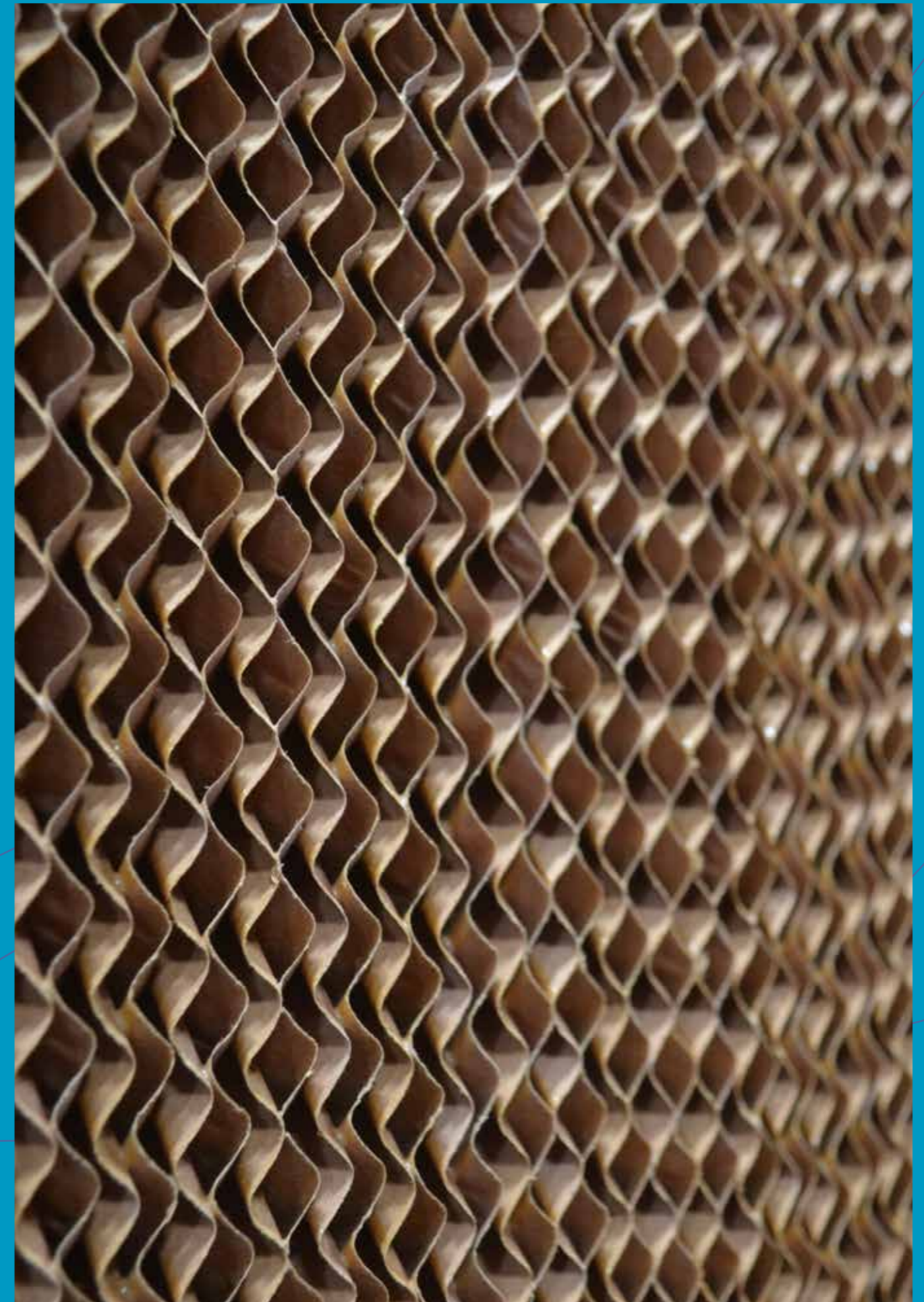

ADIABATIC COOLERS MAINTENANCE FREE EC-FANS FOR CLEAN WATERS

Series of adiabatic coolers TOPAZ®

EC fans induced-draft dry coolers - for indoor or outdoor installation.

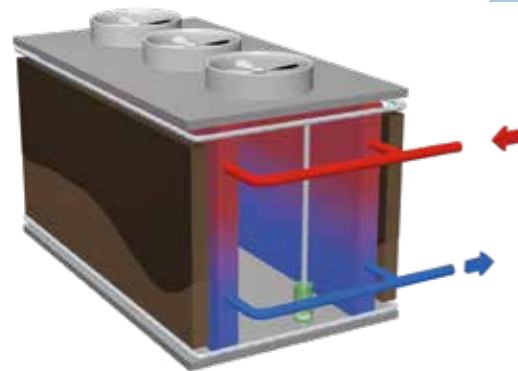

BENEFITS

- ▶ Thermal performance certified coils
- ▶ Very low operating costs
- ▶ No water treatment necessary
- ▶ No spraying of water into the air flow
- ▶ No aerosols - legionella free
- ▶ Very high switch-over point from wet to dry operation at approx. 23°C
- ▶ Full access to interior spaces makes servicing easy

- ▶ The adiabatic cooler TOPAZ® is a combination of a dry cooler and an adiabatic cooling track before the air inlet. Adiabatic pre-cooling is activated when the water outlet temperature is higher than needed. The cooling medium is cooled to below the ambient air temperature completely abacterial and without water treatment. (wet to dry switch-over point about 23°C)

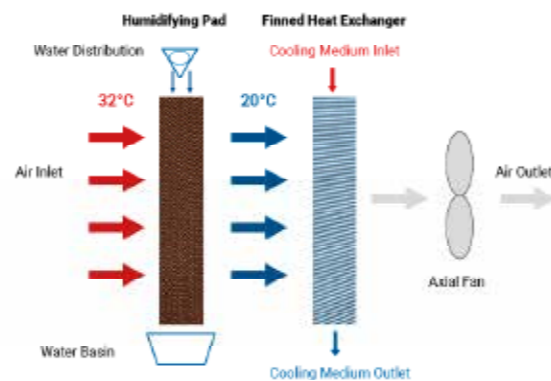

WATER SAVINGS

Collected water can be recirculated without any bacteriological risk (temperature is below the level for bacterial growth) The water consumption is then divided by a factor of 3 during adiabatic mode operation.



EASY MAINTENANCE:

- ▶ Access through complete opening
- ▶ Maintenance free EC-Fans



Series of fully drainable and non-freezing adiabatic coolers TOPAZ®

EC fans induced-draft dry coolers - for indoor or outdoor installation.



OPTIONAL:

- ▶ Geometry of the coils allowing complete draining by gravity without any injection of compressed air.
- ▶ Plug-and-play functionality
- ▶ opportunity for winter operation without glycol (drainage function)
- ▶ Master-slave regulation for serial installations

EC-FANS MAINTENANCE FREE ADIABATIC COOLERS

Series of adiabatic coolers ZYRCO

EC-fans induced-draft adiabatic dry coolers for indoor or outdoor installation.

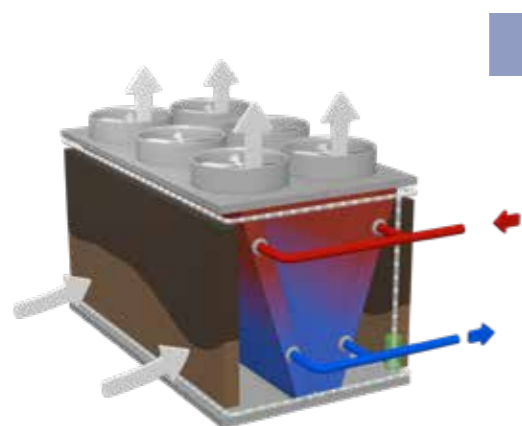

BENEFITS

- ▶ Thermal performance certified coils
- ▶ Very low operating costs
- ▶ Inside access
- ▶ No water treatment necessary
- ▶ No spraying of water into the air flow
- ▶ No aerosols - legionella free
- ▶ Very high switch-over point from wet to dry operation at approx. 23°C

- ▶ The adiabatic cooler ZYRCO is a combination of a dry cooler and an adiabatic cooling track before the air inlet. Adiabatic pre-cooling is activated when the water outlet temperature is higher than needed. The cooling medium is cooled to below the ambient air temperature completely abacterial and without water treatment. (wet to dry switch-over point about 23°C).

EC-Technology

MAINTENANCE-FREE AND LOW-NOISE EC AXIAL FANS

The perfect interaction of technically mature components produces the highest possible system efficiency. Optimized flow paths maximize efficiency and minimize noise emissions.



OPTIONAL:

- ▶ Plug-and-play functionality
- ▶ Master-slave regulation for serial installations

EC-FANS MAINTENANCE FREE ADIABATIC CONDENSERS

Series of adiabatic Condensers ONYX for ammonia NH3

EC-fans Induced-draft adiabatic condensers, for indoor or outdoor installation.

The ONYX range combines latest technologies to achieve the expected and safe performance from an environmentally focused heat rejection system

- ▶ Condensing at lower temperature than ambient air
- ▶ No water spray in the airflow
- ▶ Optimized water consumption – no water treatment required
- ▶ Easy maintenance: full internal access to all components
- ▶ Highly efficient EC technology motors
- ▶ ErP 202x compliant

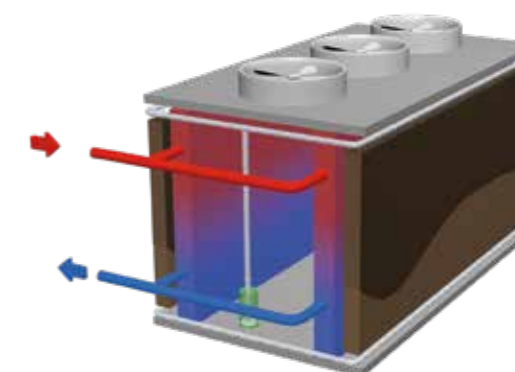

- ▶ **ONYX SAFE®**
Refrigerant containment and protection device



Safety Frame®

Building containment sleeve for better condenser refrigerant management



Safety Pulse®

Refrigerant abatement system in case of leak detection



Safety Drain®

safe recovery and evacuation network

Complete equipment dedicated to maintenance are located on a single side of the unit



Safety Side



EVAPORATIVE CONDENSERS

- ▶ Ammonia R717
- R14
- R17
- R114
- R134A
- R404A
- R407c
- R407F
- R410A
- R422A
- R448A
- R449A
- R507A
- R513A
- Freon 12
- Freon 22
- Propane r29
- Propane R290
- Genetron

COUNTER FLOW - EVAPORATIVE CONDENSERS CENTRIFUGAL FORCED-DRAFT FANS FOR CLEAN WATERS

- ▶ Water evaporative condenser, closed-type equipped with a hot dip galvanised carbon steel tube coil heat exchanger.

Series of Closed circuit cooling towers CFR-C

Centrifugal Forced-draft fans - evaporative condensers for indoor and outdoor installation.

BENEFITS

- ▶ Low noise level thanks to the centrifugal fans
- ▶ Self-supporting and high resistance Z-725 (725 g/sqm of zinc) galvanized steel metal frame and panels
- ▶ Condensing cooling by means of an internal tubes coil
- ▶ Wide range of heat rejection capacities
- ▶ Easy and economical transportation and installation of the sections
- ▶ Certified coils (PED)

Tube coil
Heat Exchanger



- ▶ Designed for condensing gases such as ammonia or other refrigerant gases, the CFR-C series is particularly suitable for industrial refrigeration plant applications where reliability, efficiency, quiet operation and low operating cost are required.

COUNTER FLOW - EVAPORATIVE CONDENSERS AXIAL INDUCED-DRAFT FAN FOR CLEAN WATERS

Series of Closed circuit cooling towers CFR-A

Axial Induced-draft fan - evaporative condensers for outdoor installation.

Tube coil
Heat Exchanger



BENEFITS

- ▶ Low management costs, mainly thanks to low consumption of the motors driving the fans
- ▶ Self-supporting and high resistance Z-725 (725 g/sqm of zinc) galvanized steel metal frame and panels
- ▶ Condensing cooling by means of an internal tubes coil
- ▶ Wide range of heat rejection capacities
- ▶ Easy and economical transportation and installation of the sections
- ▶ Certified coils (PED)

- ▶ CFR-A model is designed and manufactured in accordance with the Quality System certified according to ISO 9001:2015 standards and according to the Directive 2014/68/EU (PED), which guarantees the pressure tightness of coils installed up to 40 bar and authorizes its use with pressures up to 28 bar.





SERVICES

SERVICES DEPARTMENT

In addition to our skills and know-how in designing and manufacturing our products, our SERVICES business is **constantly listening to users**, and aims to offer the **best economical solution** based on the strong values that have built our DNA:

REACTIVITY – KNOW-HOW – INNOVATION – CUSTOMER SATISFACTION

- ▶ For **optimum performance** and **controlled operating costs**, our qualified experts can provide you with **customised solutions** for all types of cooling towers or adiabatic equipment to **guarantee reliable availability of your installation** all year long.



EXPERTISE

Our **qualified experts** have the skills to assess problems on all types and brands of cooling towers. Our **technical advice** during the on-site assessment enables us to offer you **optimised solutions for appropriate maintenance**, repairs or renovations needed to ensure that your equipment is running correctly.



THERMAL DIAGNOSIS

- ▶ By taking into account changes in your process or the condition of your cooling towers, the on-site thermal balance provides a **detailed view of the current performance** of your installation. This diagnosis helps you to plan for improved performance.



SERVICES

Our **experience on site** as a manufacturer of cooling towers and adiabatic equipment guarantees, first and foremost, high-quality work for all cooling tower types by our **experts trained in our specific activities**, and **tailored support** for all preventive maintenance, with **turnkey job management**.



- ▶ Refurbishing cooling towers and adiabatic coolers is essential to ensure **long-term performance**, the **longevity** of the equipment and the **reliability** of a complete process, while keeping operating costs and bacteriological risks under control.

DECSAMONITOR

DecsaMonitor is innovative 4.0 service that enables remote monitoring of vital cooling tower parameters, alerting in advance and promptly to any anomalies.



DECSAMONITOR SENSOR

The DecsaMonitor solution is as simple as it is effective: the sensor can be installed on new cooling towers and on already installed retrofitted cooling towers.

SERVICES DEPARTMENT

MAINTENANCE

The operating conditions and environment of the installation are determining factors in the choice of service frequency. To **maintain original performance**, we recommend at least annual preventive maintenance.

Our experience as a manufacturer has shown over the years that the DECSA, JACIR and GOHL-KTK maintenance contracts set up with our customers has made a major contribution to the **longevity of the equipment and its components**.



IMPROVING PERFORMANCE & TECHNOLOGY DEVELOPMENT

Our recognized know-how and experience enable us to completely renovate cooling towers, to guarantee the reliability of your equipment's operation, and provide you with our commitment to new performance.

Our support extends from a detailed analysis by our dedicated design office for the modernisation of cooling towers or the increase in capacity through the integration of new-generation components, to the complete management of human and material resources in compliance with safety regulations.



ENERGY EFFICIENCY

The operating conditions and environment of the installation are determining factors in the choice of service frequency. To **maintain original performance**, we recommend at least annual preventive maintenance.

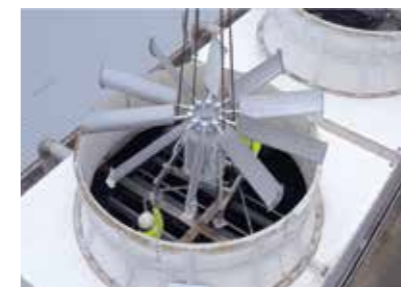

- ▶ Reducing water and electricity consumption is one of our major challenges. Replacing the key components of your equipment with innovative solutions will **reduce your energy and water consumptions**.

BOOSTCOOLER® SAFE ADIABATIC COOLING FOR DRY COOLERS AND CHILLERS

BoostCooler® technology is a secure adiabatic cooling system for Dry Coolers and Chillers. It makes it possible to overcome operating problems such as the collapse of performance and the drift of COP, the degradation of the coils due to direct watering, or even a non-compliance of safety requirements.

The BoostCooler® system uses the evaporation of water in adiabatic mode and thus makes it possible to obtain a cold water temperature lower than that of the ambient air.



BENEFITS

- ▶ Maintenance of cold water temperature during hot conditions
- ▶ Increasing of heat rejection
- ▶ Lowering of cold water temperature
- ▶ No drift guaranteed
- ▶ Increase the cooling capacity of chillers and secure these installations, even during heat waves
- ▶ Reduce the compressors' operation, energy and maintenance costs

RENTAL

A fleet of dedicated rental machines is available and our support service will design, deliver, install and supervise your temporary cooling solution in record time.



INDUSTRIAL RETROFIT

The task of our qualified experts is to understand and analyse the challenges facing your installation. We provide a customised technical solution for all types of cooling tower structures: wood, concrete, steel, FRP, etc. to give you optimum performance, controlled operating costs and reliability of your process all year long.



BENEFITS

- ▶ For all application fields, including: chemical and petrochemical plants, sugar refineries, steelworks, metalworks, foundries, refineries, paper mills, etc.
- ▶ The most appropriate technical solution for the needs and constraints of the process
- ▶ Compliance with site safety regulations
- ▶ Guaranteed thermal performance
- ▶ Complete management of human and material resources
- ▶ Ensuring that the project is completed on schedule



REFERENCES

► As one of the leading experts of evaporative cooling, JACIR, DECSA and GOHL-KTK are recognised as global leaders in the design and manufacturing in France, Italy and Germany of an extensive range of cooling towers, adiabatic coolers and condensers.

Our products comply with local environmental regulations, meet stringent sound requirements and are built with a variety of fan combinations, materials and exchange surfaces choice. They are designed for applications including HVAC, food, dairy, chemical, pulp and paper...

More than 38.000 cooling towers projects realised worldwide to over 100 countries are clear proof of our capability.

We are committed to offering clients the best solutions to maintain reliability and optimise the performance of their cooling equipment.

A CONVINCING PERFORMANCE

ENERGY

EON - RWE - Siemens - Philipps - Thyssen Krupp - Lech Stahlwerke - Alstom Power - Total - Engie...

MEDIA & STORES

Springer - Bundesdruckerei - SWR - Burda Medien - Bayerischer Rundfunk - WDR - IKEA - Louis Vuitton...

PUBLIC INSTITUTION

Airports Hamburg, Frankfurt - Aéroports de Paris - Messe München, Hamburg...

INDUSTRY

O-I Manufacturing - Arcelor - Fibre Excellence - Saint Gobain...

FINANCE

Credit Suisse - Bank of America - Zürcher Kantonalbank - Commerzbank...

CHEMICALS AND PHARMACEUTICAL INDUSTRY

BASF - Grünenthal - Degussa - Bayer - Takeda - GlaxoSmithKline - Air Liquide...

AUTOMOTIVE INDUSTRY

Opel - Audi - BMW - VW - Porsche - Airbus - Mercedes - Ford - Michelin - Toyota - PSA - Dacia...

FOOD INDUSTRY

Danone - Nestlé - Lactalis - Tereos...

JACIR S.A.S
11, rue Jean Moulin
77348 Pontault-Combault Cedex - France
Tel.: +33 1 6443 5320
contact@jacir.fr
www.jacir.fr

DECSA Srl
Str. Cappelletta, 1
27058 Voghera PV - Italy
Tel.: +39 0383 69411
info@decsa.eu
www.decsasrl.com

GOHL-KTK GmbH
Schlosserstraße 5
76448 Durmersheim - Germany
Tel.: +49 7245 91916 0
kuehlturm@kuehlturm.de
www.gohl-ktk.de

www.cofinair-group.com

COFINAIR Group_09.2023



Cooling for life