

SF and SFIM

Closed Circuit Cooling Tower

Closed Hybrid Cooler

CONTENT	Page(s)
Closed circuit cooling tower	2
Closed cooling tower principle and operation	3
Closed hybrid cooling tower principle and operation	4
Manufacturing details – Options	5-10
Technical characteristics – SF	11
Drawings and dimensions - SF without sound attenuation	12-13
Drawings and dimensions – SF with IB sound attenuation	14-15
Drawings and dimensions – SFIM with ICV-ICVK-Special	16-17
Technical characteristics – SFIM	18
Drawings and dimensions – SFIM without sound attenuation	19-20
Drawings and dimensions – SFIM with IB sound attenuation	21-22
Drawings and dimensions – SFIM with ICV-ICVK-Special	23-24
Support SF	25
Support SFIM	26
On site layout	27
Water treatment	28
Prescription SF	29-31
Prescription SFIM	32-34

Closed circuit cooling tower SF - SFIM

JACIR

With more than 60 years' experience, our company:

- ∞ Has invested in detailed research and development in order to propose technical solutions in accordance with environmental protection through unequalled realizations and patents.
- ∞ Is today the European leader thanks to its technology beyond market requirements.

STRONG BENEFITS OF THE SF - SFIM

- ∞ **SECURITY AND HYGIENE** Compliant with hygienic standards
- ∞ **PLATE HEAT EXCHANGER** Made of stainless steel, the plates are removable to ease the cleaning.
- ∞ **NO FREEZING RISK** Glycol free Plate Heat Exchanger without winter freezing risks.
- ∞ **WATER PROOF** Thanks to our assembling technology, we guaranty no leak equipment.
- ∞ **SILENCE** Very silent cooling towers in standard version, can be adapted according requirements.
- ∞ **EXCHANGE SURFACE** **EFFI-PACK:** Highly efficient and easy to maintain, excellent resistance to temperature (75°C continuous) the infill may support use till 95°C as an option.
- ∞ **ANTICORROSION COATING** Made of galvanized steel as a standard, the casing of the tower is assembled without any welding, also proposed in **X-STEEL** stainless steel (corrosion resistance superior to 316L).
- ∞ **EASY MAINTENANCE** Large access doors, fan outside the tower and at man chest, inclined and plane basin for a complete drain.
- ∞ **EVOLUTIVE TOWER** Possible to increase the exchanged power by addition of plates, to lower the sound level without increasing the motor power.
- ∞ **MODULAR CONSTRUCTION** Easy handling and transport.

Closed cooling tower principle and operation SF

A cooling tower is a heat exchanger, which enables water to be cooled through direct contact with air. The heat transfer from the water to the air is carried out partly by sensible heat transfer, but mainly by latent heat transfer (evaporation of part of the water into the air), which makes it possible to reach cooling temperatures lower than ambient temperatures.

Closed circuit cooling tower operation:

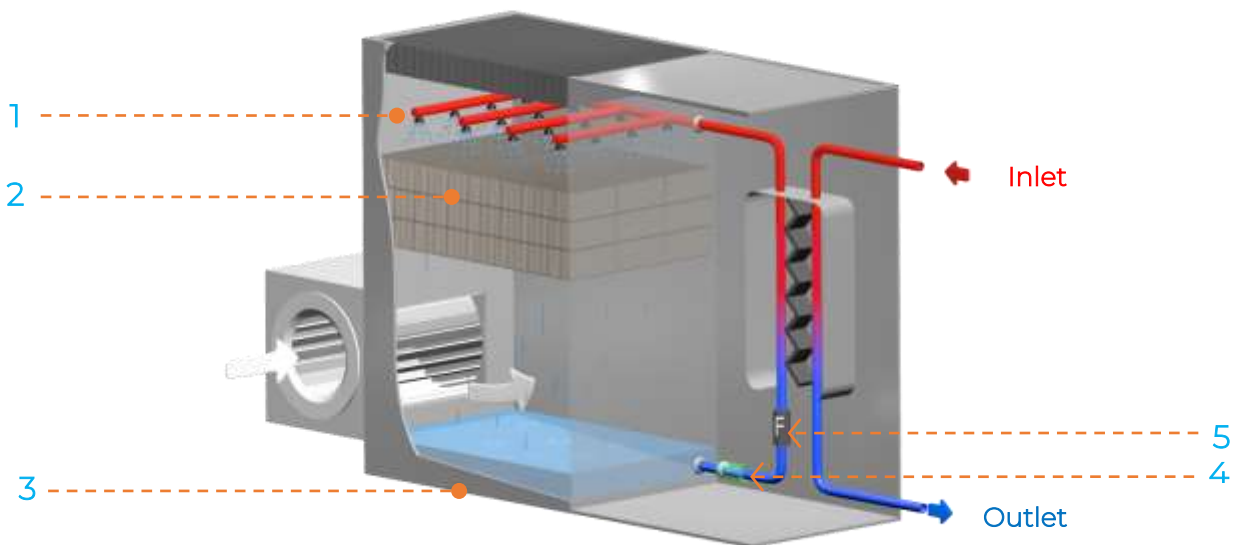

The fluid to be cooled flows through the primary circuit of a stainless-steel plate heat exchanger (inlet/outlet). The water from the secondary circuit, flows from the heat exchanger by pipes to the top of the cooling tower. This water is distributed on the exchange surface (2) through the nozzles (1).

The air is forced by the fan from the bottom to the top of the cooling tower. During the pass, it has been warmed up and saturated in water through the exchange surface.

Because of the superficial tension created by the exchange surface, the water equally flows down along the whole height of the so extended exchange surface.

Cooled by the forced air, the water falls by gravity to the inclined basin (3) located on the bottom of the tower.

This water is recycled on the plate heat exchanger by the circulating pump (4) filtered by a strainer and then by a FRC centrifugal filter (5).

Closed Hybrid cooling tower principle and operation SFIM

Standard SF closed circuit cooling tower ranges have originally been designed to receive the plume abatement coil option; these SF ranges are then referred to as SFIM Closed Hybrid Cooler range. Their efficiency is ensured by a finned tube coil combined with a valve for adjusting the water spray on the exchange surface (packing). This water flow regulation over the exchange surface is market exclusivity, (JACIR patent).

Therefore, the combination of the air desaturation by air outlet warming up, and the reduction of the water spray on the packing, ensures the complete plume suppression. Beyond the plume suppression itself, this system can provide water savings up to 80 % and is an ultimate obstacle to the drifts.

This technology proposed by JACIR has been deeply researched in partnership with the CETIAT for over 40 years, and has offered the opportunity to file innovating patents.

The closed-circuit hybrid towers are perfectly adapted for operating without glycol in winter. Their design makes access and cleaning very easy and ensures performance durability.

Operation:

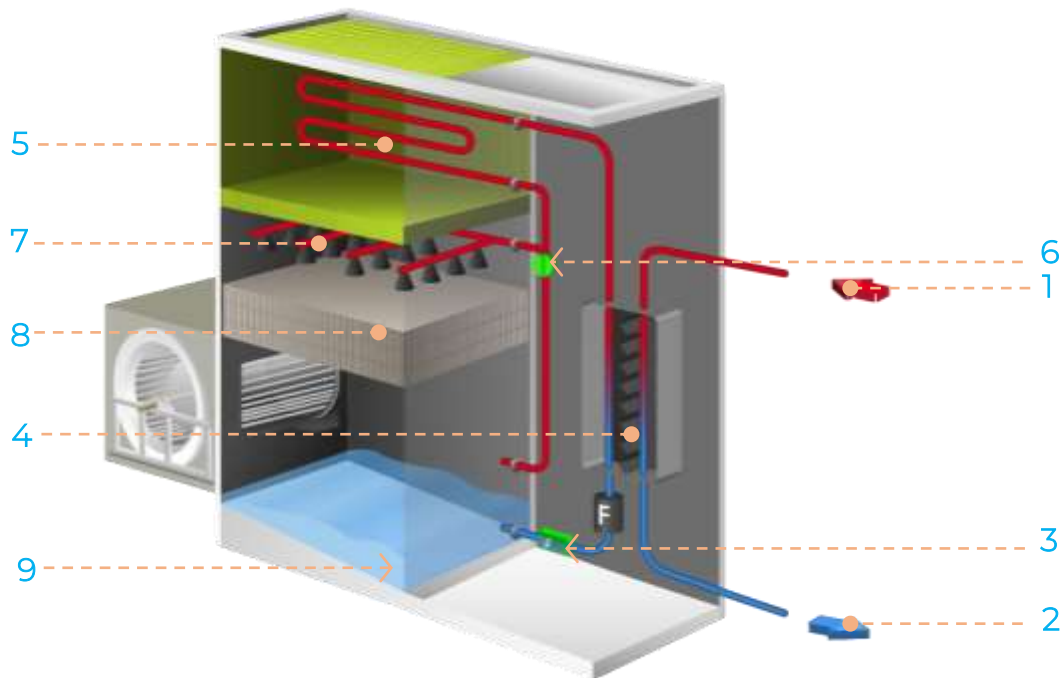

Process (primary) Side:

The water to be cooled (1) enters into the integrated plate heat exchanger and exits once cooled (2). Primary (user) circuit is closed and is not in contact with the air.

Cooling tower side (evaporation):

Water is sucked up by a pump (3), circulates through the plate heat exchanger (4) filtered by a strainer and a FRC centrifugal filter, and enters into the non-freezing plume suppression coil (5) (JACIR patent); then, via a power-activated valve (6), water goes either to the water spraying system (7) to be distributed over the exchange surface (8), or directly to the basin if the ambient conditions are cold enough for a dry cooling. The water cooled thanks to the forced draft fan, falls into the bottom cooling tower sloped basin (9).

No freezing risk and easy maintenance:

This technology does not require glycol to avoid exchanger freezing risk. Designed for an easy cleaning or descaling of all the cooling tower components by a very simple operation maintenance.

Manufacturing details and options SF - SFIM

I – AIR - WATER EXCHANGE: TOWER CIRCUIT

Casing structure

Self-supporting rigid panels, with 2 or 4 folds on the four sides, (**JACIR design**) allowing sound attenuation casing addition if required. Thanks to this technology, we can offer cooling towers with an extremely low sound level.

Towers are assembled with waterproof stainless-steel rivets (uniform, high-capacity locking).

There is no welding on assembled panels for the parts in contact with water; a high covering seal ensures the close fit between the panels. Folds and cutting plan are all outside oriented.

As standard model, the panels are in galvanised steel mm2 thick ZENDZIMIR process 275 gr / m² (galvanised plates are protected by the zinc oxidation on the surface).

Silver Steel or **X-STEEL** stainless steel (corrosion resistance superior to 316L one) are optional.



Sloped and flat basin

The sloped and plan basin allows a **complete and easy drain**.

On the utilities panels of the basin are located:

- ∞ Overflow,
- ∞ Drain below the lower level of the basin and **POWER FLOW** access enabling to quickly and completely evacuate all sludge and other accumulated parts in the bottom of the casing using simple water spray,
- ∞ **FRC centrifugal filter (JACIR patented)** (260 x 110 mm): 100 % of the cooling tower flow is filtered continuously every 1-2 minute at 60µm,
- ∞ Make-up water by float valve or electro valve as an option,
- ∞ Water outlet through a removable strainer (made of stainless steel or PEHD) with a flange, oversized to eliminate cavitation, with a perforated steel plate,
- ∞ Large doors to access the basin through a rectangular access (540x 390 mm).
- ∞ Option: electrical heater of V 230 or V 400 and waterproof thermostat with separate bulb and automatic cleaning generated by opening the purge circuit (with the DAi option).

By the way, evaporation circuit stays clean and avoids Legionella's growth risk.



Exchange surface: EFFI-PACK

Made of thermoformed and welded Polypropylene sheets, this heat exchange surface is resistant to chocks and offers a large available surface. Resistant up to 75°C, its excellent thermal efficiency favours energy saving.

Also called infill, EFFI-PACK is made of PP and offers a maximal heat exchange surface:

- ∞ High temperature resistance (75 °C continuous),
- ∞ High-efficiency, extended surface,
- ∞ Easy maintenance,
- ∞ High resistance to chemical agents,
- ∞ Range of operation up to 95°C (option).

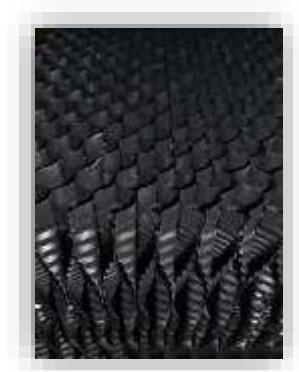

Water distribution

Water distribution is made of PVC pipes through highly efficient water distributors. The nozzles made of polypropylene distribute the water in the shape of a full jet cone over the exchange surface.

The nozzles are bolted (stainless steel screws) to the distribution pipes, for easy maintenance and strong mechanical resistance.

An internal turbulator distributes the water so that a uniform water distribution reaches the exchange surface.

The nozzles are selected according to distribution pressure and flow rate.



Drift eliminators

Highly efficient, drift eliminators are made of PP sheets and prevent the water from being sprayed out of the tower: the drift is 0.01 % maximum of the re-circulating water flow. This value has been Eurovent certified.

Ultraviolet resistant, they are easy to remove from the top in order to access to the distributors and to the exchange surface.

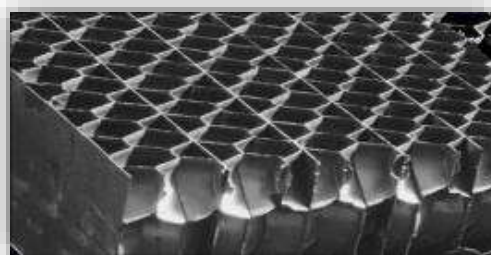

Fans

The centrifugal fans are specially designed and manufactured by **JACIR**. The impeller is a double side air inlet type. The air inlet ducts are removable to access to the impeller, and are made of polyester. Their shape noticeably improves the performances of the fans.

The bearings are self-aligning, lubricated in our factory and to be regularly lubricated thanks to a copper deposited line lubrication as a standard for a simple and quick maintenance without any removal.

Each fan is associated with its own motor.

The volutes side-plates are used to fix the motor support. This design prevents the belts from producing a slapping effect.

Trapezoidal pulleys and V-belts transmission are used. Tension is applied to the belts by tipping the motor seat, for easy adjustment.

The impeller is protected from corrosion by a baked epoxy coating. The elliptical scroll is made of X-STEEL stainless steel.

Optionally, the impeller can be made of stainless-steel.

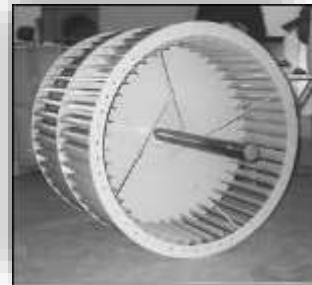

Motors

- ∞ IE3 asynchronous three-phases motor, Frequency drive compliant,
- ∞ 1500 rpm,
- ∞ 230/400 V up to 5.5 kW,
- ∞ 400/690 V above 5.5 kW,
- ∞ Hz 50,
- ∞ IP55 (possible open sky operating),
- ∞ F/B Class,
- ∞ Direct connection to terminal box,



Accessibility

As a standard, the basin is equipped with access door(s) sized 390 x 540 mm, and one **POWER FLOW** access sized 260x110 mm: located under the bottom level of the basin, it allows a fast complete drain and an easy cleaning of sludge or other accumulated parts of the bottom casing using simple water jet.

One large door sized 1290 x 640 mm in the same material as the cooling tower casing is also provided: allowing quickly removing of the drift eliminators, the nozzles, the packing (infill) and the water distribution pipes.



Non-freezing plume suppression coil (JACIR patent) – SFIM option

As a standard, the coil is made of X-STEEL stainless steel.

Two air vents secure the freezing risk. This “cover” type configuration protects the coil from accidental damage related to possible freeze-over.

The tubes are assembled in a triangular pitch, made of copper (stainless-steel option)

The fins are in copper.

A monitored valve adjusting the water flow sprays over the infill, associated to the plume coil.

As soon as ambient conditions are met, this system makes it possible to operate **significant water saving** by cooling the water in the dry mode, rather than spraying and evaporating it.



II – WATER-WATER EXCHANGE: PROCESS CIRCUIT

Integrated exchanger room to the cooling tower

Made of galvanized steel in standard (X-STEEL stainless steel option), self-supporting stiff panels equipped with an access door (2100 x 600 mm) with key lockers. The panels can be disassembled, and all components are designed for easy access and maintenance.

As a standard, the exchanger room is equipped with automatic presence detection lightening. Electrical heater is available as an option.



Plate Heat Exchanger

It is protected from weather conditions inside its dedicated room.

User's connection is directly fixed outside the room to facilitate connection with primary circuit, with only two connections: inlet and outlet located either in the cooling tower axe or perpendicularly. It does not require antifreeze protection: in case of electrical stop, the water-cooling tower circuit automatically drains by gravity down the basin, protecting by the way plates and gaskets of the plate heat exchanger. For easy re-assembly, JACIR selects with symmetrical plates and clipped gaskets.

Heat exchanger pump

Protected against freezing by a patented thermostatic valve: no electrical tracing need. A water level switch is included and a pump frequency drive is also proposed as an option.

Pressure meters

Installed before and after the pump, and also before water distribution piping.

FRC Centrifugal filter

Located at the basin outlet, a 5 mm filtration strainer is installed.

A **FRC centrifugal filter** chosen in the same material as the piping (galvanized or 304 – 316L stainless steel options) is located at the plate exchanger inlet.

It offers the following characteristics:

- ∞ 100 % of the cooling tower flow is filtered continuously every minute: very high efficiency,
- ∞ High efficiency at 60µm for all elements with density superior to 1,
- ∞ Automatic cleaning during the blow down of the water circuit = JACIR patented system option.

The evaporative water circuit remains clean, thus reducing the risk of legionella proliferation.

Automatic Inductive blow down (AiD)

Automatic Inductive blow down is available in option.



III – SOUND ATTENUATION (options):

IB standard sound attenuation

Additional casing of the air inlet fan(s), made of self-supporting rigid steel panels covering, double folding on the 4 internal sides of the panels. Internal lagging is made of absorbent sound material. Complete access door is provided for a total accessibility maintenance in front door with 4 lockers, activated by key.

At the air outlet, an exhaust cone reduces the acoustic emission surface.

ICV complete sound attenuation

Additional casing of the air inlet fan(s), made of self-supporting rigid steel panels covering, double folding on the 4 internal sides of the panels. Internal lagging is made of absorbent sound material and contains sound acoustics baffles. These galvanized steel sound baffles, made of high-density rock wool panels, are easily removable.

At the air inlet, the rock wool is coated by a fibre glass layer.

At the air outlet, baffles receive a reinforced protection by a stainless-steel grid.

ICVK complete sound attenuation with double casing

The entire casing of ICV cooling tower is fitted with a double casing: high density rock wool covered by an additional steel sheet - ICVK.

Special sound attenuation

ICVK solution is adapted to reach required sound level, up to NR 30 at 10m.

OPTIONS

- ∞ Pump frequency drive,
- ∞ **X-STEEL** stainless-steel plate heat exchanger room,
- ∞ Non-freezing plume suppression coil system (**SFIM**),
- ∞ SILVER STEEL casing option,
- ∞ **X-STEEL** stainless-steel casing (resistance to corrosion superior to 316L),
- ∞ Non-freezing heater with thermostat,
- ∞ Electrical convector for plate heat exchanger room heating,
- ∞ 2 speeds motor (separate wiring or PAM – 1500/1000 rpm),
- ∞ Fans frequency drive,
- ∞ Water level control with electric-valve and input filter,
- ∞ Automatic Inductive Deconcentration (see AiD documentation),
- ∞ All accessories made of stainless steel (fan casing, wheel, plume suppression coil, etc.),
- ∞ Discharge cone (air outlet speed increased with lower sound radiation and recycling),
- ∞ **EFFI-SILENT** basin sound abatement,
- ∞ Available air pressure for connection to the duct,
- ∞ Equipment delivered in parts, to be assembled on site,
- ∞ Assembly on site by our experimented technicians.

Technical characteristics SF

CLOSED COOLING TOWER WITHOUT SOUND ATTENUATION

	Heat power ref. average (1) [kW]	Fans Qty	Outlet air flow rate [m3/h]	Water Heater power [kW]	Motor power [kW]	Sound level (2) at 20 m [dB(A)]	Weight empty (without beams) [kg]	Weight full (without beams) [kg]	Overall dimensions (with exhaust cone option) [mm]
SF-1812	260	1	28 000	3	9	50	1 885	2 980	H = 2 630 L = 4 395 I = 1 600
SF-2415	430		47 000	3	15	52	2 300	3 915	H = 2 700 L = 5 165 I = 1 600
SF-2718	590		64 000	6	18.5	53	2 795	4 890	H = 2 900 L = 5 710 I = 1 900
SF-3021	770		82 000	6	22	54	3 890	6 700	H = 3 050 L = 6 170 I = 2 200

CLOSED COOLING TOWER IB SOUND ATTENUATION

	Heat power ref. average (1) [kW]	Fans Qty	Outlet air flow rate [m3/h]	Water Heater power [kW]	Motor power [kW]	Sound level (2) at 20 m [dB(A)]	Weight empty (without beams) [kg]	Weight full (without beams) [kg]	Overall dimensions (with exhaust cone option) [mm]
SF-1812 IB	250	1	28 000	3	9	44	2 235	3 325	H = 2 630 L = 6 195 I = 1 600
SF-2415 IB	420		47 000	3	15	46	2 735	4 345	H = 2 700 L = 7 165 I = 1 600
SF-2718 IB	570		64 000	6	18.5	47	3 300	5 395	H = 2 900 L = 8 010 I = 1 900
SF-3021 IB	750		82 000	6	30	48	4 475	7 280	H = 3 050 L = 8 720 I = 2 200

CLOSED COOLING TOWER ICV – ICVK - Special SOUND ATTENUATIONS

	Heat power ref. average (1) [kW]	Fans Qty	Outlet air flow rate [m3/h]	Water Heater power [kW]	Motor power [kW]	Sound level (2) at 20 m [dB(A)]	Weight empty (without beams) [kg]	Weight full (without beams) [kg]	Overall dimensions (with exhaust cone option) [mm]
SF-2415 ICV	410	1	47 000	3	18.5	39	4 035	5 645	H = 4 440 L = 7 165 I = 1 600
SF-2415 ICVK						36	4 545	6 160	
SF-2415 Special						On demand	4 750	6 365	
SF-2718 ICV	560	1	64 000	6	22	40	4 785	6 880	H = 4 440 L = 8 010 I = 1 900
SF-2718 ICVK						37	5 385	7 480	
SF-2718 Special						On demand	5 625	7 720	
SF3021 ICV	730	1	82 000	6	30	41	6 145	8 950	H = 4 720 L = 8 720 I = 2 200
SF3021 ICVK						38	6 860	9 660	
SF3021 Special						On demand	7 145	9 945	

(1): Reference power is based on thermal data 32 / 27 / 21°C.

(2): Sound level: average pressure level (Lp) in free field in 4 directions at 1.5m high.

Note: for higher power, towers can be added side by side.

Drawings and dimensions SF without sound attenuation

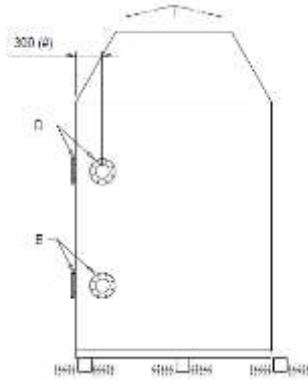
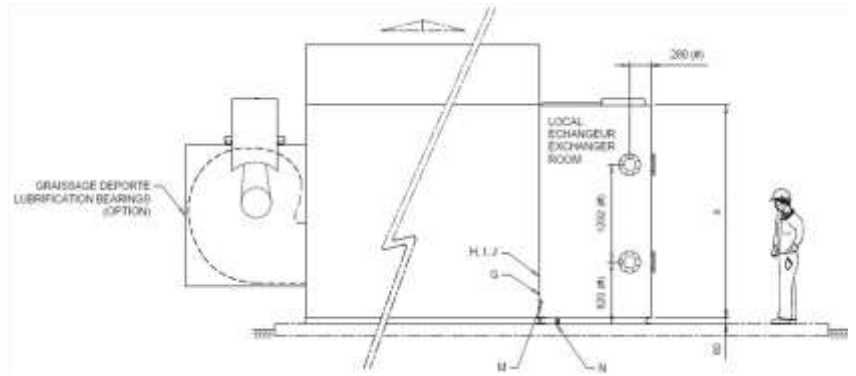
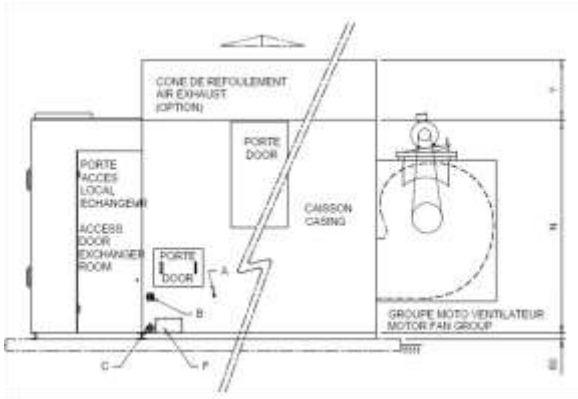

			SF 1812	SF 2415	SF 2718	SF 3021
Dimensions N (mm)			2 400	2 530	2 670	2 820
Dimensions X (mm)			2 420	2 420	2 670	2 820
Dimensions Y (mm)			600	700	700	800
A	Electro vanne Float valve (male)	Ø*	3/4"	1"	1"	1"1/2
		Ø*	1"	1"1/4	1"1/4	1"1/4
	Water make up	X	1 100	1 650	1 950	2 200
		Y	585	585	585	585
B	Overflow	DN	50	50	50	50
		X	1 800	2 400	2 700	3 000
		Y	560	560	560	560
C	Drain (female)	DN	50	50	50	50
		X	1 800	2 400	2 700	3 000
		Y	150	150	150	150
D	Hot water inlet	DN	150	150	150	150
		X	**	**	**	**
		Y	**	**	**	**
E	Cold water outlet	DN	150	150	150	150
		X	**	**	**	**
		Y	**	**	**	**
F	Drain basin POWER FLOW					
G	Non-freezing heater with integrated thermostat (option)					
H - I	Water level switch (option)					
J	Safety water level (low/high) (option)					
M	Outlet blow down (option)					
N	Outlet Exogel and drain pump					

*: According to thermal data

** : According selected servitudes

Drawings and dimensions SF without sound attenuation

PLAN DE POSE SF1812
SF1812 BASEMENT

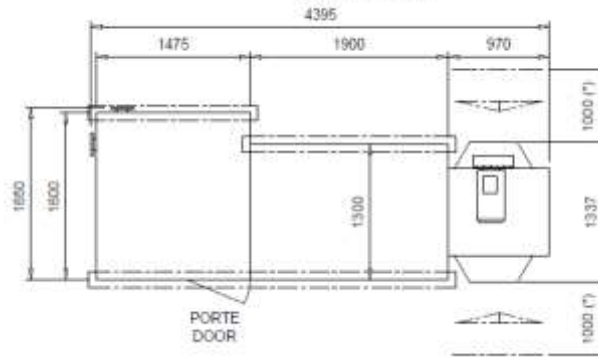

PLAN DE POSE SF2415
SF2415 BASEMENT

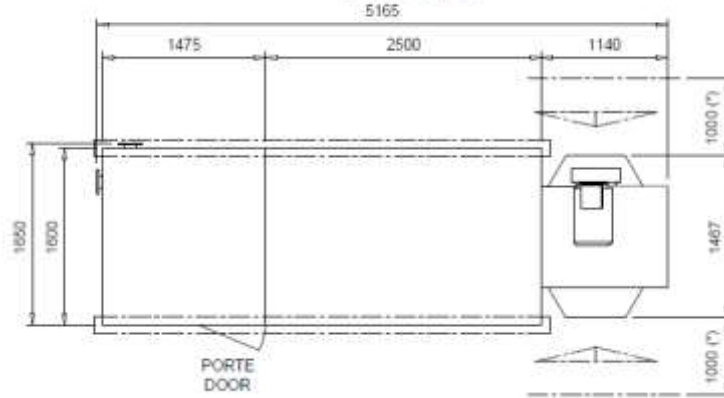

PLAN DE POSE SF2718
SF2718 BASEMENT

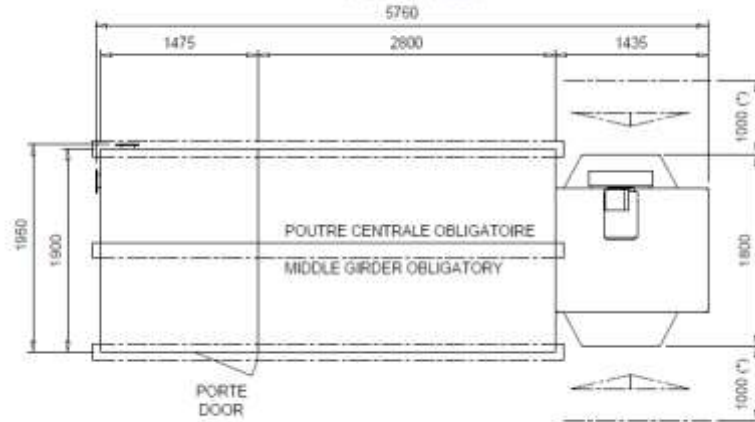

PLAN DE POSE SF3021
SF3021 BASEMENT

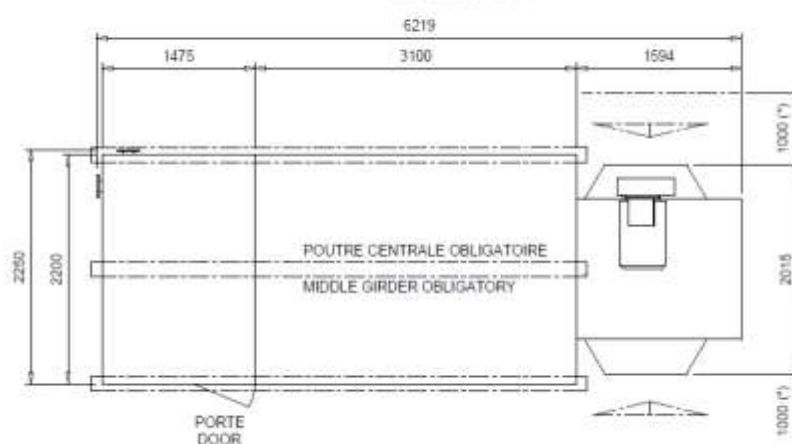

Drawings and dimensions SF with IB sound attenuation

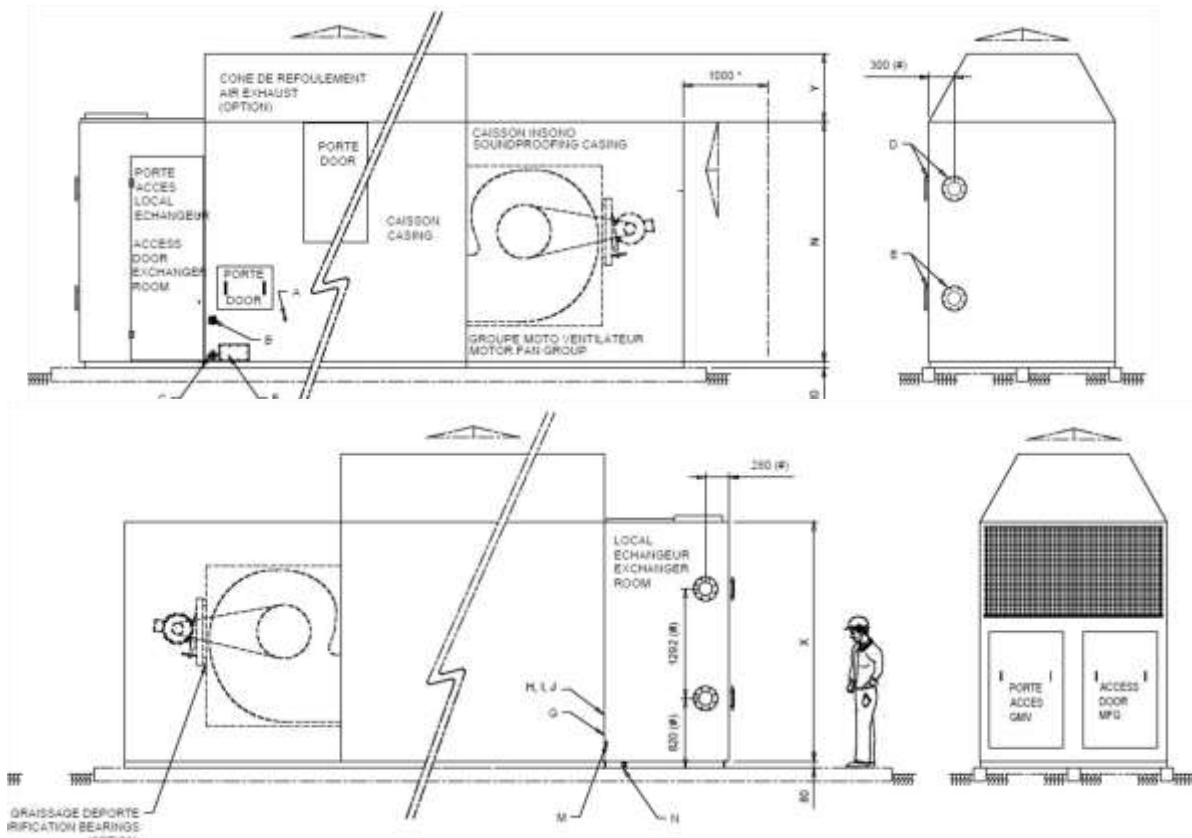

			SF 1812 IB	SF 2415 IB	SF 2718 IB	SF 3021 IB
Dimensions N (mm)			2 400	2 530	2 670	2 820
Dimensions X (mm)			2 420	2 420	2 670	2 820
Dimensions Y (mm)			600	700	700	800
A	Electro vanne Float valve (male)	Ø*	3/4"	1"	1"	1"1/2
		Ø*	1"	1"1/4	1"1/4	1"1/4
	Water make up	X	1 100	1 650	1 950	2 200
B	Overflow	Y	585	585	585	585
		DN	50	50	50	50
		X	1 800	2 400	2 700	3 000
C	Drain (female)	Y	560	560	560	560
		DN	50	50	50	50
		X	1 800	2 400	2 700	3 000
D	Hot water inlet	Y	150	150	150	150
		DN	100	100	100	150
		X	**	**	**	**
E	Cold water outlet	Y	**	**	**	**
		DN	100	100	100	150
		X	**	**	**	**
F	Drain basin POWER FLOW					
G	Non-freezing heater with integrated thermostat (option)					
H - I	Water level switch (option)					
J	Safety water level (low/high) (option)					
M	Outlet blow down (option)					
N	Outlet Exogel and drain pump					

*: According to thermal data

** : According selected servitudes

Drawings and dimensions SF with IB sound attenuation

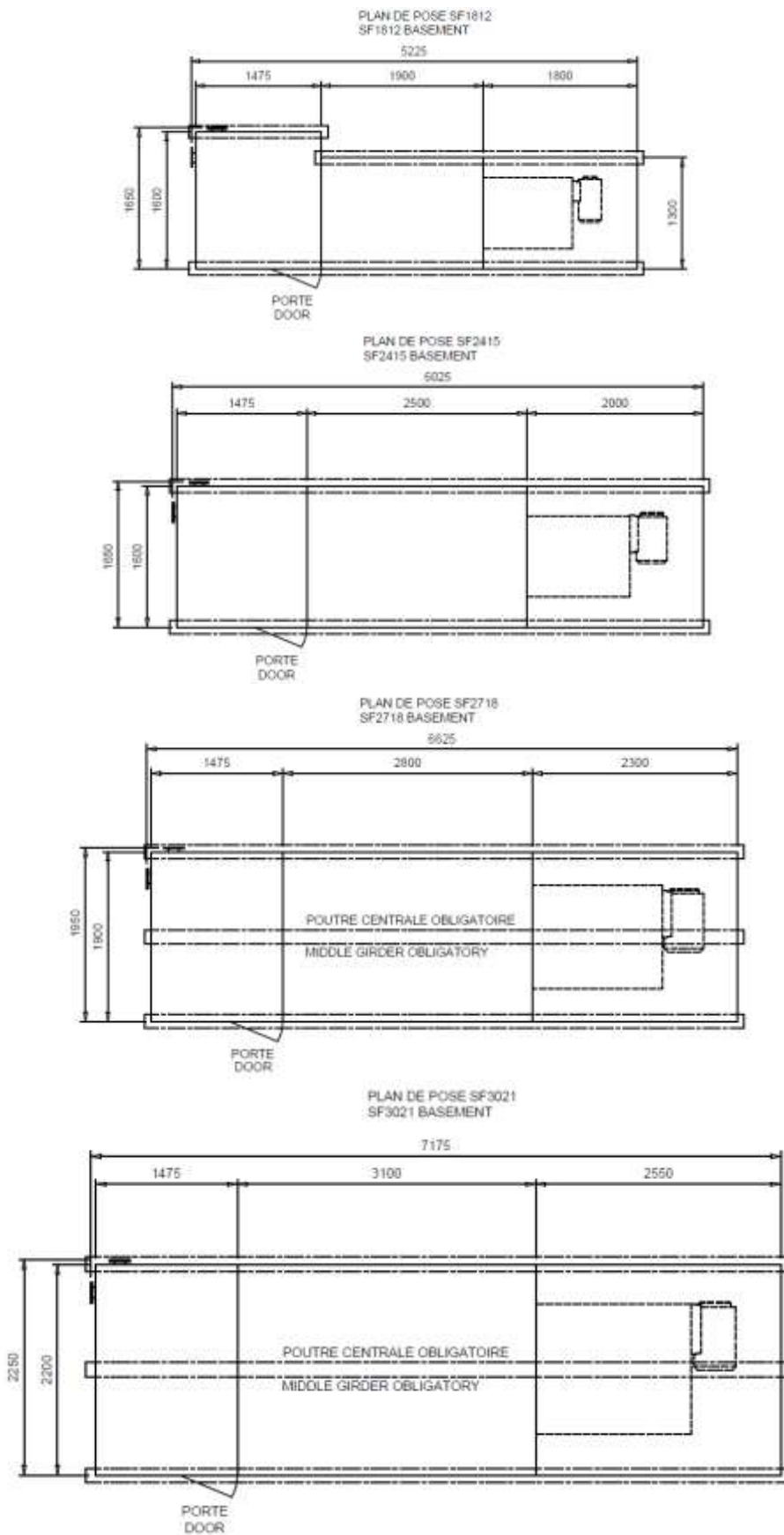

Drawings and dimensions SF with ICV sound attenuation

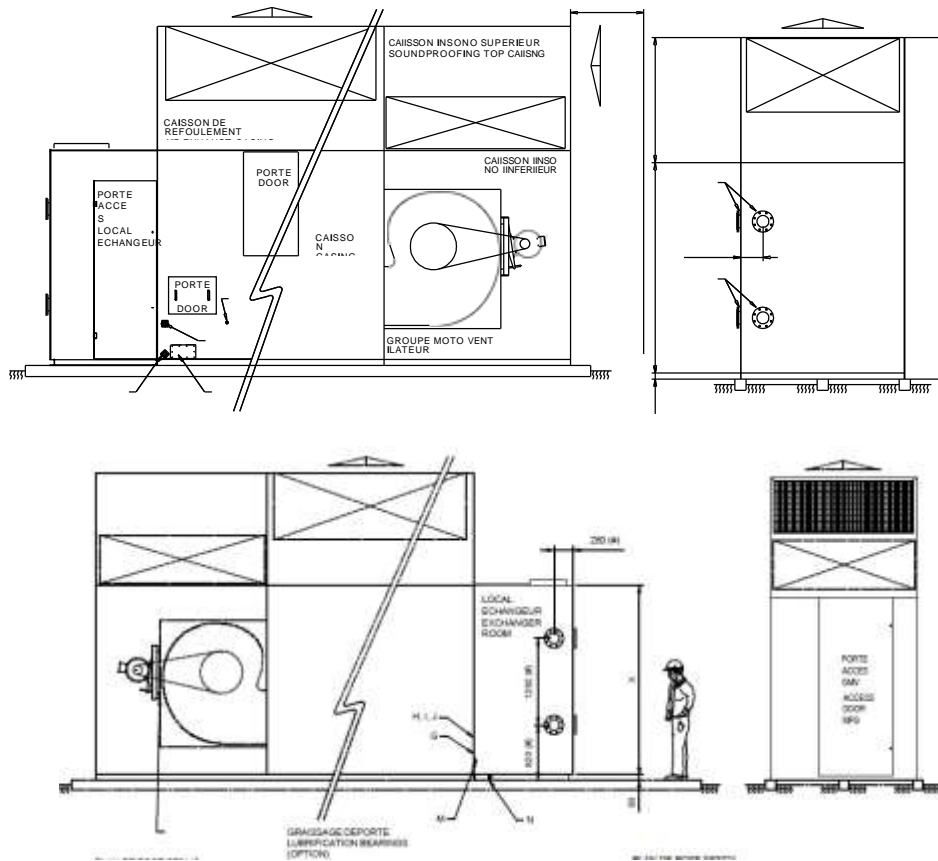

			SF 2415 ICV	SF 2718 ICV	SF 3021 ICV
Dimensions N (mm)			2 530	2 670	2 820
Dimensions X (mm)			2 420	2 670	2 820
Dimensions Y (mm)			4 290	4 430	4 580
A	Electro valve	Ø*	1"	1"	1"1/2
	Float valve (male)	Ø*	1"1/4	1"1/4	1"1/4
	Water make up	X	1 650	1 950	2 200
		Y	585	585	585
B	Overflow	DN	50	50	50
		X	2 400	2 700	3 000
		Y	560	560	560
C	Drain (female)	DN	50	50	50
		X	2 400	2 700	3 000
		Y	150	150	150
D	Hot water inlet	DN	100	100	150
		X	**	**	**
		Y	**	**	**
E	Cold water outlet	DN	100	100	150
		X	**	**	**
		Y	**	**	**
F	Drain basin POWER FLOW				
G	Non-freezing heater with integrated thermostat (option)				
H-I	Water level switch (option)				
J	Safety water level (low/high) (option)				
M	Outlet blow down (option)				
N	Outlet Exogel and drain pump				

*: According to thermal data

** : According selected servitudes

Drawings and dimensions SF with ICV sound attenuation

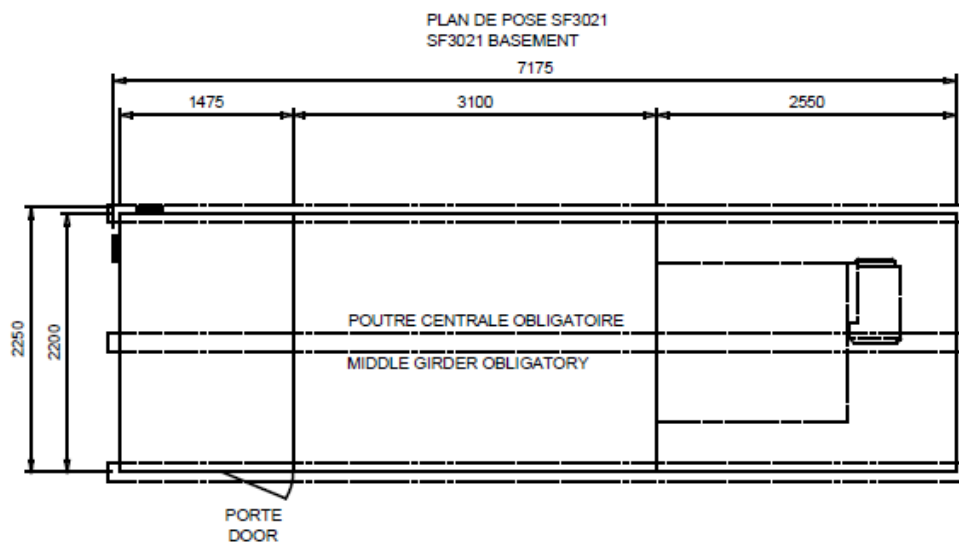
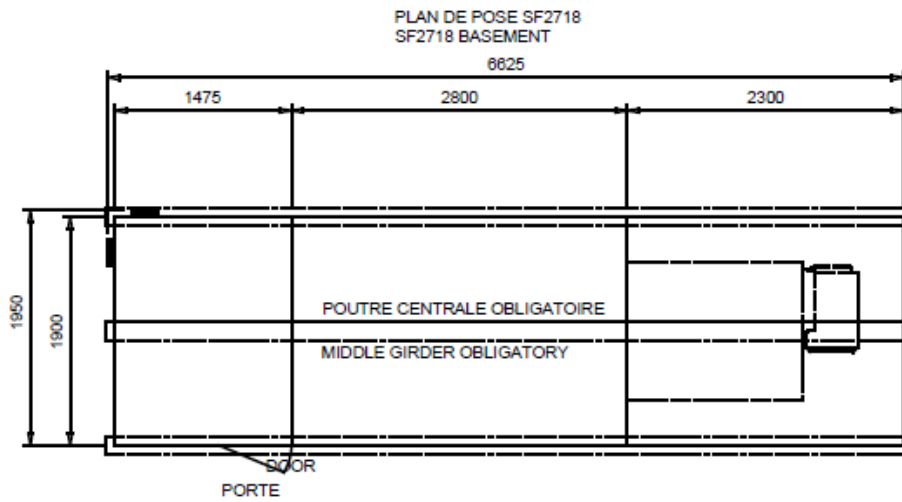
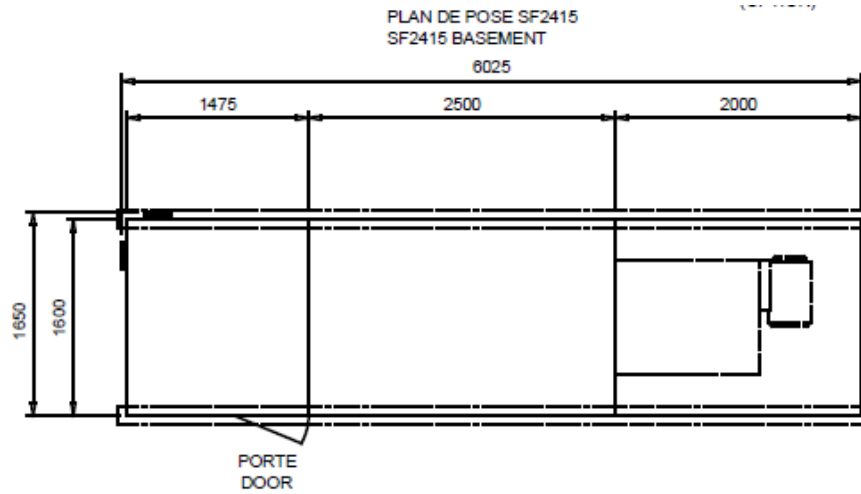

Technical characteristics SFIM

HYBRID CLOSED COOLING TOWER WITHOUT SOUND ATTENUATION

	Heat power ref. average (1) [kW]	Fans Qty	Outlet air flow rate [m3/h]	Water Heater power [kW]	Motor power [kW]	Sound level (2) at 20 m [dB(A)]	Weight empty (without beams) [kg]	Weight full (without beams) [kg]	Overall dimensions (with exhaust cone option) [mm]
SFIM-1812	260	1	27 000	3	9	50	2 055	3 255	H = 3 090 L = 4 345 I = 1 920
SFIM-2415	430		45 600	3	15	52	2 570	4 330	H = 3 270 L = 5 165 I = 2 220
SFIM-2718	590		62 000	6	18,5	53	3 145	5 435	H = 3 400 L = 5 705 I = 2 600
SFIM-3021	770		80 000	6	22	54	4 340	7 365	H = 3 550 L = 6 165 I = 2 815

HYBRID COOLING TOWER IB SOUND ATTENUATION

	Heat power ref. average (1) [kW]	Fans Qty	Outlet air flow rate [m3/h]	Water Heater power [kW]	Motor power [kW]	Sound level (2) at 20 m [dB(A)]	Weight empty (without beams) [kg]	Weight full (without beams) [kg]	Overall dimensions (with exhaust cone option) [mm]
SFIM-1812 IB	250	1	27 000	3	9	44	2 405	3 600	H = 3 790 L = 5 175 I = 1 920
SFIM-2415 IB	420		45 600	3	15	46	3 000	4 760	H = 3 970 L = 5 975 I = 2 220
SFIM-2718 IB	570		62 000	6	18,5	47	3 650	5 940	H = 4 100 L = 6 575 I = 2 600
SFIM-3021 IB	750		80 000	6	22	48	4 920	7 950	H = 4 250 L = 7 125 I = 2 815

CLOSED HYBRID COOLING TOWER ICV – ICVK – SPECIAL SOUND ATTENUATIONS

	Heat power ref. average (1) [kW]	Fans Qty	Outlet air flow rate [m3/h]	Water Heater power [kW]	Motor power [kW]	Sound level (2) at 20 m [dB(A)]	Weight empty (without beams) [kg]	Weight full (without beams) [kg]	Overall dimensions (with exhaust cone option) [mm]
SFIM-2415 ICV	410	1	45 600	3	18.5	39	4 300	6 060	H = 5 650 L = 5 975 I = 2 220
SFIM-2415 ICVK						36	4 815	6 570	
SFIM-2415 Special						On demand	5 020	6 675	
SFIM-2718 ICV	560	1	62 000	6	22	41	5 135	7 425	H = 5 780 L = 6 575 I = 2 600
SFIM-2718 ICVK						38	5 735	8 025	
SFIM-2718 Special						On demand	5 975	8 265	
SFIM-3021 ICV	730	1	80 000	6	30	42	6 590	9 620	H = 5 930 L = 7 125 I = 2 815
SFIM-3021 ICVK						39	7 300	10 330	
SFIM3021 Special						On demand	7 585	10 615	

(1): Reference power is based on thermal data 32 / 27 / 21°C.

(2): sound level: average pressure level (Lp) in free field in 4 directions at 1.5m high.

Note: for higher power, towers can be added side by side.

Drawings and dimensions SFIM without attenuation

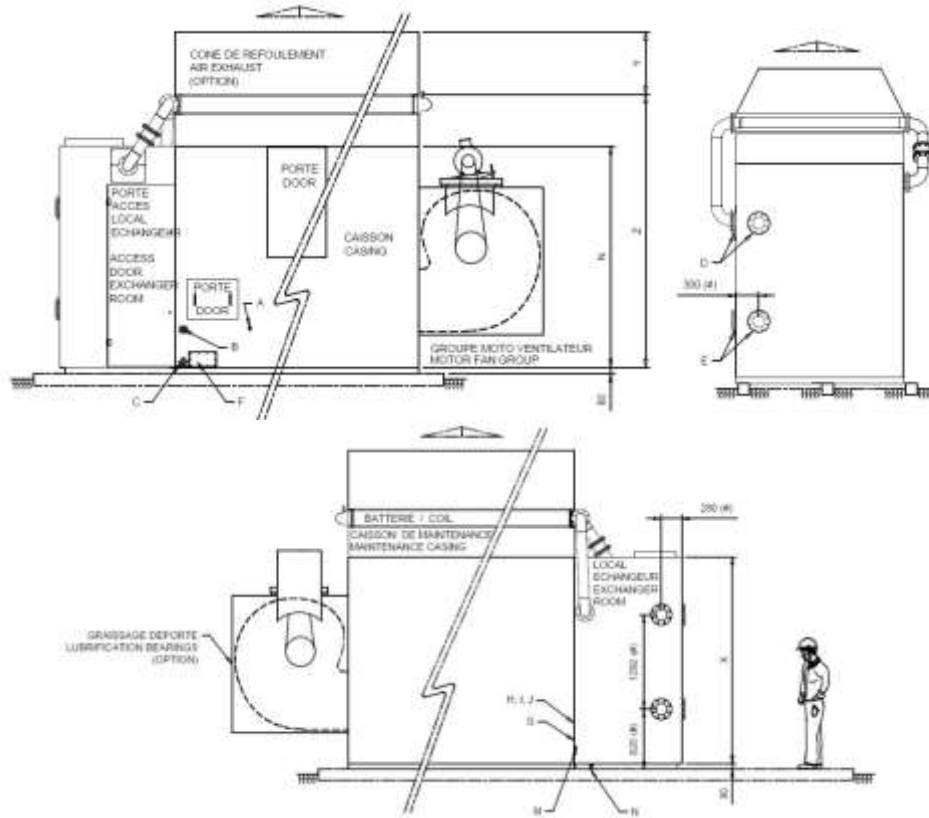

			SFIM 1812	SFIM 2415	SFIM 2718	SFIM 3021
Dimensions N (mm)			2 400	2 530	2 670	2 820
Dimensions X (mm)			2 420	2 420	2 670	2 820
Dimensions Y (mm)			600	700	700	800
Dimensions Z (mm)			3 130	3 260	3 400	3 550
A	Electro vanne Float valve (male)	Ø*	3/4"	1"	1"	1"1/2
		Ø*	1"	1"1/4	1"1/4	1"1/4
	Water make up	X	1 100	1 650	1 950	2 200
B	Overflow	DN	50	50	50	50
		X	1 800	2 400	2 700	3 000
		Y	560	560	560	560
C	Drain (female)	DN	50	50	50	50
		X	1 800	2 400	2 700	3 000
		Y	150	150	150	150
D	Hot water inlet	DN	100	100	100	150
		X	**	**	**	**
		Y	**	**	**	**
E	Cold water outlet	DN	100	100	100	150
		X	**	**	**	**
		Y	**	**	**	**
F	Drain basin POWER FLOW					
G	Non-freezing heater with integrated thermostat (option)					
H - I	Water level switch (option)					
J	Safety water level (low/high) (option)					
M	Outlet blow down (option)					
N	Outlet Exogel and drain pump					

*: According to thermal data

** : According selected servitudes

Drawings and dimensions SFIM without attenuation

PLAN DE POSE SFIM1812
SFIM1812 BASEMENT

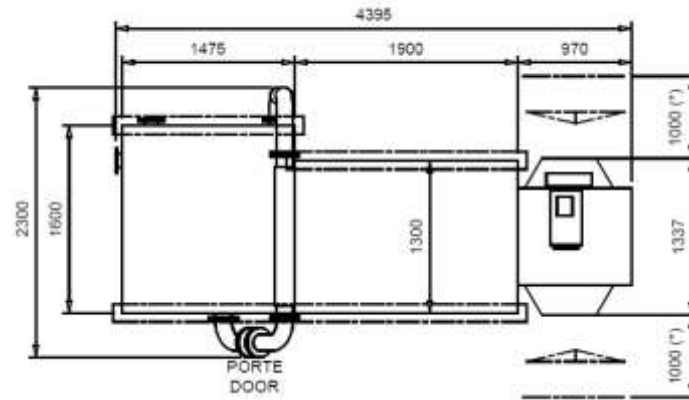

PLAN DE POSE SFIM2415
SFIM2415 BASEMENT

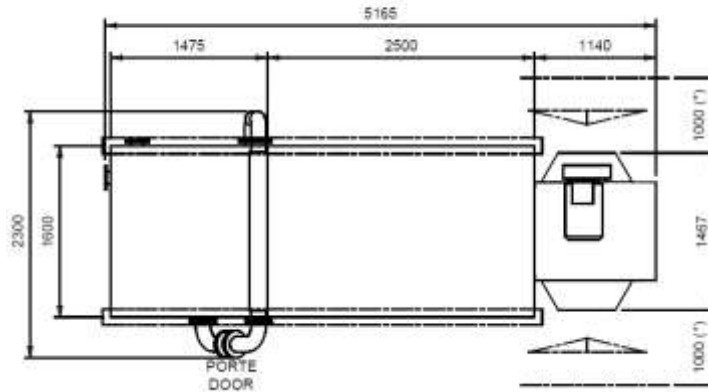

PLAN DE POSE SFIM2718
SFIM2718 BASEMENT

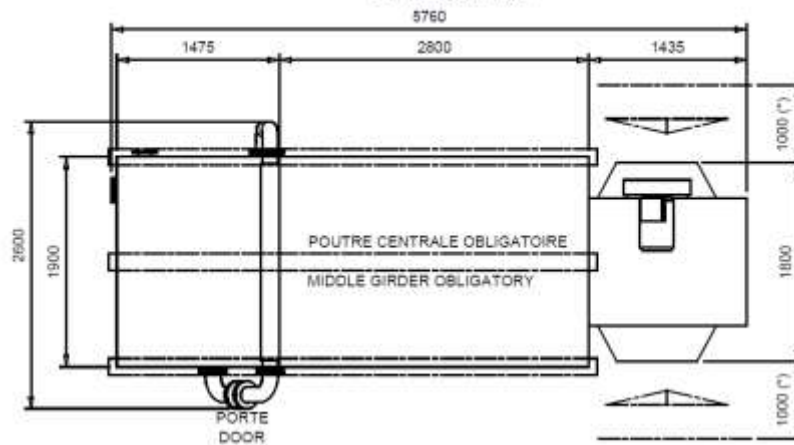

PLAN DE POSE SFIM3021
SFIM3021 BASEMENT

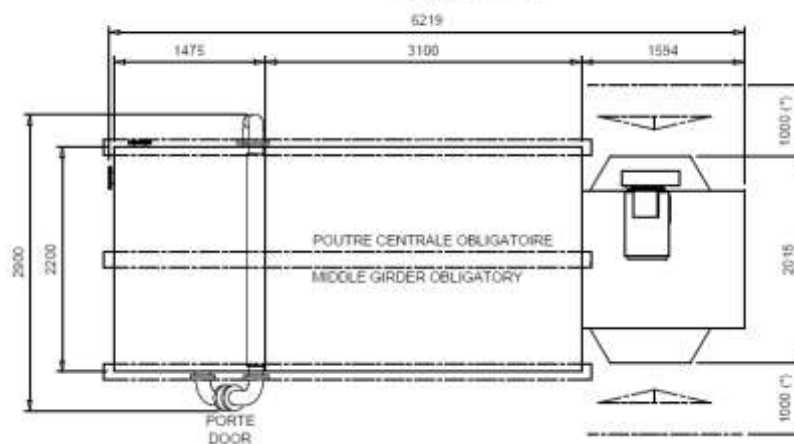

Drawings and dimensions SFIM with IB sound attenuation

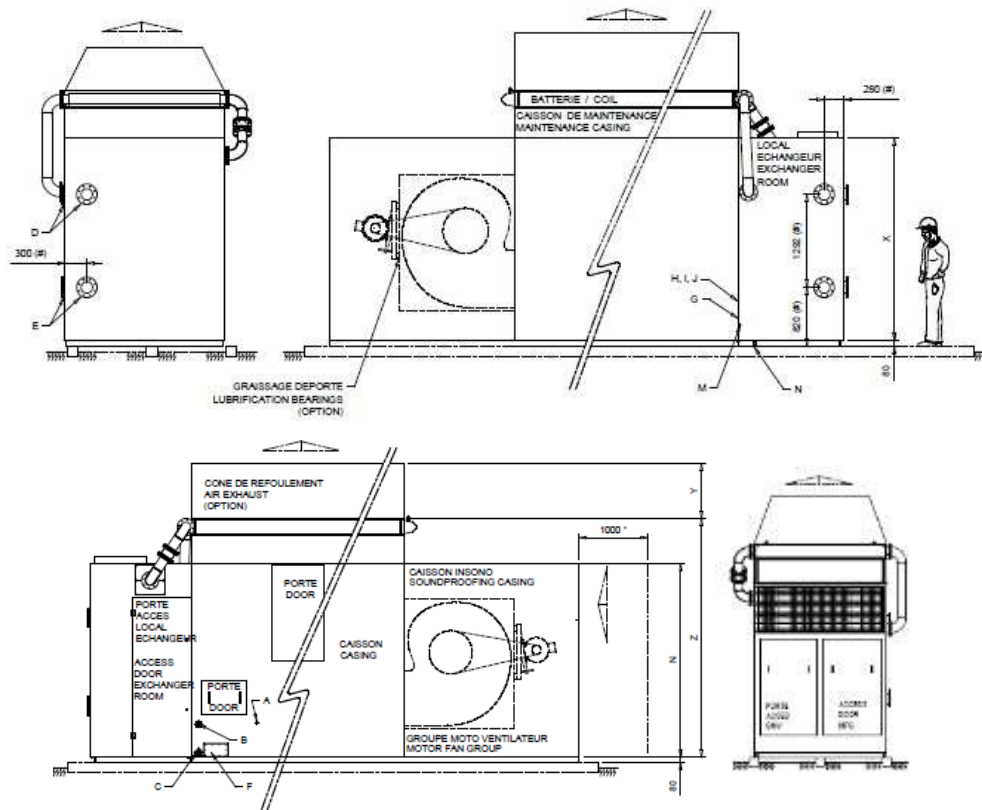

			SFIM 1812 IB	SFIM 2415 IB	SFIM 2718 IB	SFIM 3021 IB
Dimensions N (mm)			2 400	2 530	2 670	2 820
Dimensions X (mm)			2 420	2 420	2 670	2 820
Dimensions Y (mm)			600	700	700	800
Dimensions Z (mm)			3 130	3 260	3 400	3 550
A	Electro vanne Float valve (male)	Ø*	3/4"	1"	1"	1"1/2
		Ø*	1"	1"1/4	1"1/4	1"1/4
	Water make up	X	1 100	1 650	1 950	2 200
B	Overflow	Y	585	585	585	585
		DN	50	50	50	50
		X	1 800	2 400	2 700	3 000
C	Drain (female)	Y	560	560	560	560
		DN	50	50	50	50
		X	1 800	2 400	2 700	3 000
D	Hot water inlet	Y	150	150	150	150
		DN	100	100	100	150
		X	**	**	**	**
E	Cold water outlet	Y	**	**	**	**
		DN	100	100	100	150
		X	**	**	**	**
F	Drain basin POWER FLOW					
G	Non-freezing heater with integrated thermostat (option)					
H-I	Water level switch (option)					
J	Safety water level (low/high) (option)					
M	Outlet blow down (option)					
N	Outlet Exogel and drain pump					

*: According to thermal data

** : According selected servitudes

Drawings and dimensions SFIM with IB sound attenuation

PLAN DE POSE SFIM1812
SFIM1812 BASEMENT

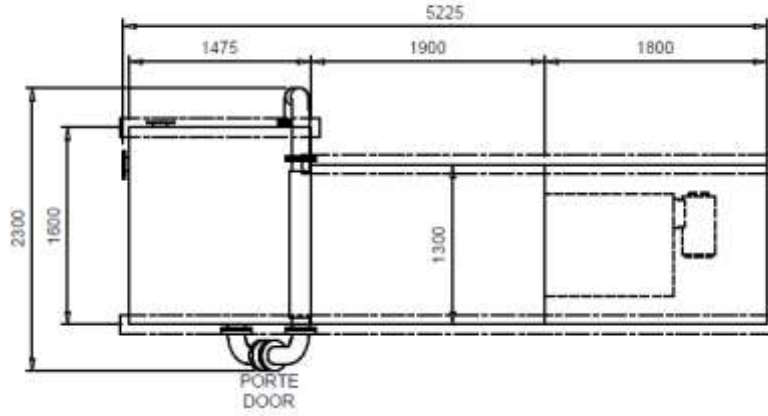

PLAN DE POSE SFIM2415
SFIM2415 BASEMENT

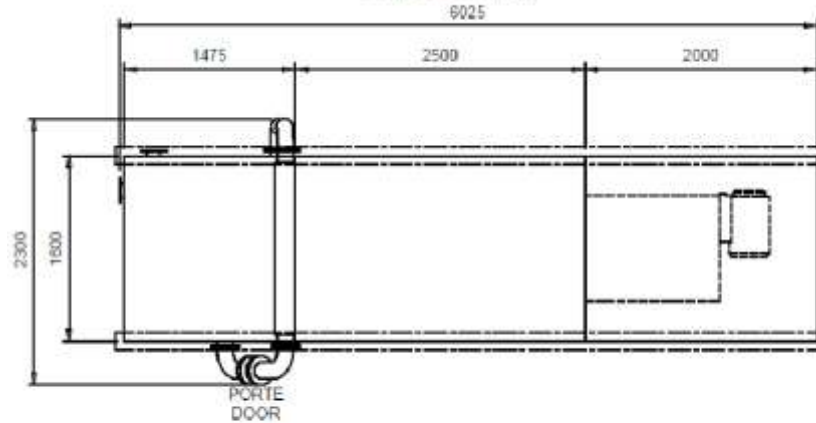

PLAN DE POSE SFIM2718
SFIM2718 BASEMENT

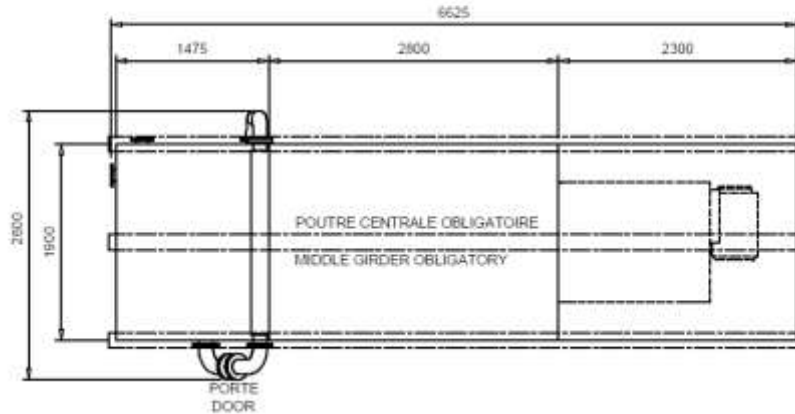

PLAN DE POSE SFIM3021
SFIM3021 BASEMENT

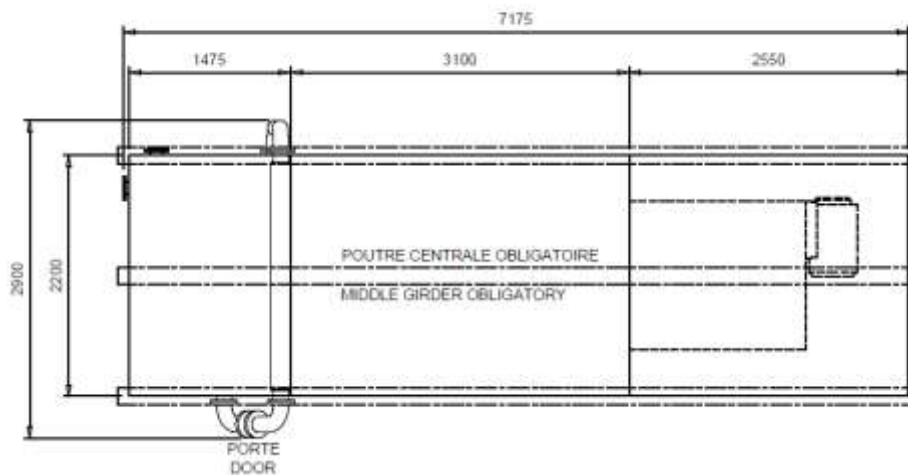

Drawings and dimensions SFIM with ICV – ICVK - Special sound attenuation

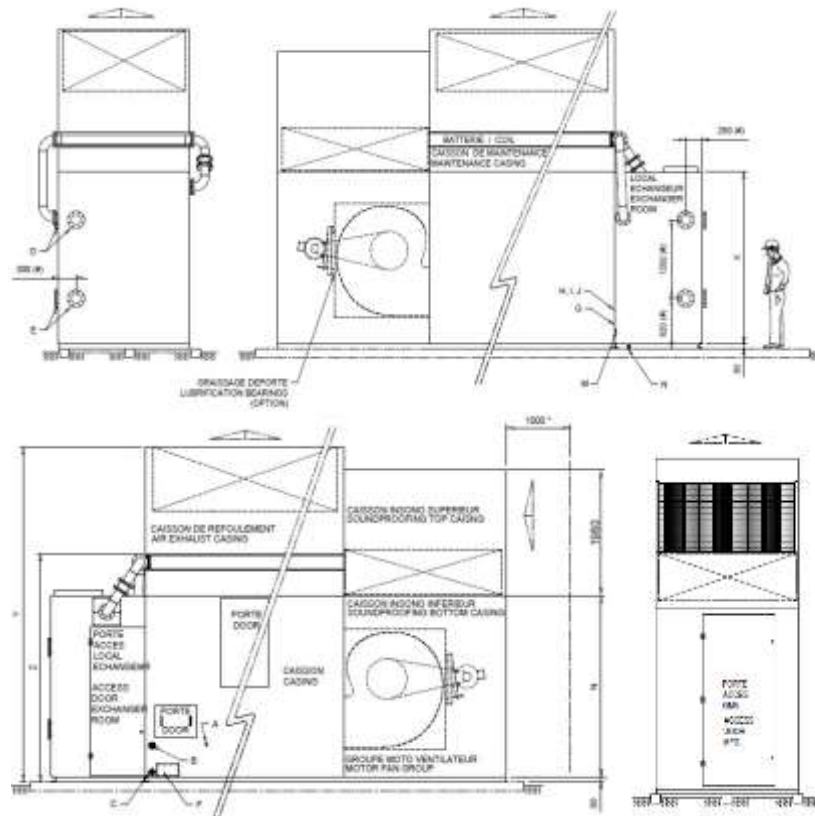

			SFIM 2415 ICV	SFIM 2718 ICV	SFIM 3021 ICV
Dimensions N (mm)			2 530	2 670	2 820
Dimensions X (mm)			2 420	2 670	2 820
Dimensions Y (mm)			4 940	4 080	4 230
Dimensions Z (mm)			3 180	3 320	4 370
A	Electro valve	Ø*	1"	1"	1"1/2
	Float valve (male)	Ø*	1"1/4	1"1/4	1"1/4
	Water make up	X	1 650	1 950	2 200
B	Overflow	Y	585	585	585
		DN	50	50	50
		X	2 400	2 700	3 000
C	Drain (female)	Y	560	560	560
		DN	50	50	50
		X	2 400	2 700	3 000
D	Hot water inlet	Y	150	150	150
		DN	100	100	150
		X	**	**	**
E	Cold water outlet	Y	**	**	**
		DN	100	100	150
		X	**	**	**
F	Drain basin POWER FLOW				
G	Non-freezing heater with integrated thermostat (option)				
H-I	Water level switch (option)				
J	Safety water level (low/high) (option)				
M	Outlet blow down (option)				
N	Outlet Exogel and drain pump				

*: According to thermal data

** : According selected servitudes

Drawings and dimensions SFIM with ICV – ICVK - Special sound attenuation

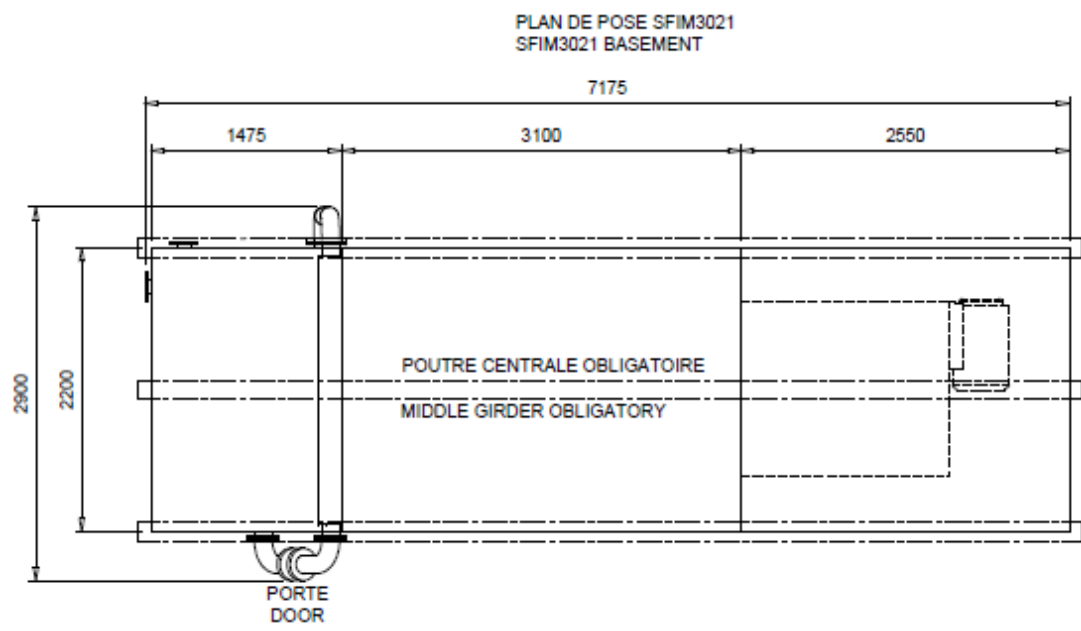
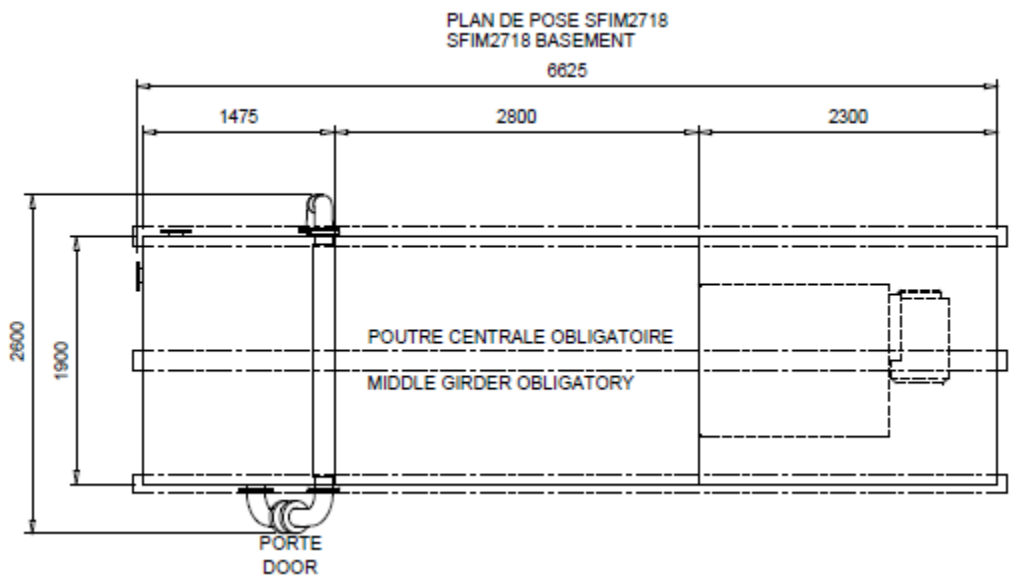
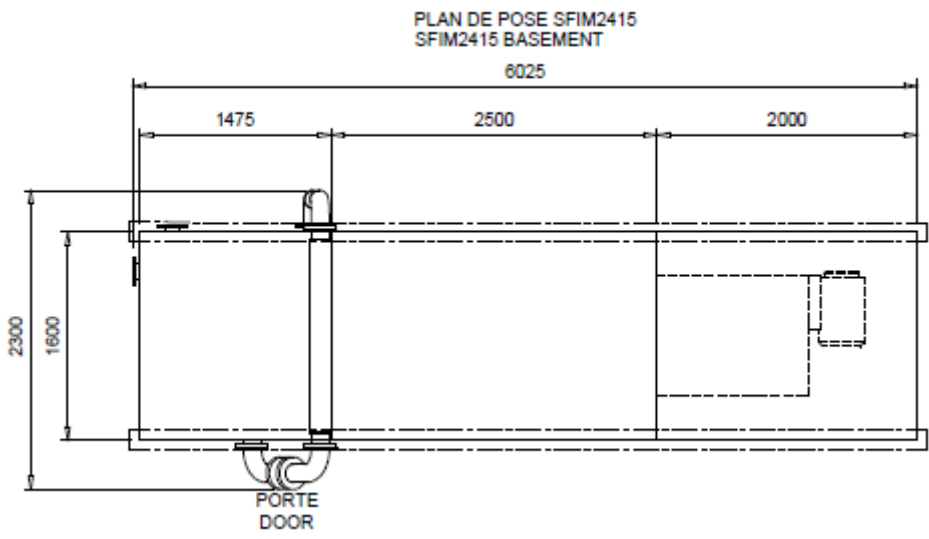

Support SF

SF cooling tower ranges can stand on a concrete base or on steel frame beams (customer supply). Check that the ground can stand the operating load, and that surface or supports are flat and horizontal.

Quantity and position of concrete or metallic beams (customer supply) for cooling towers without sound attenuation

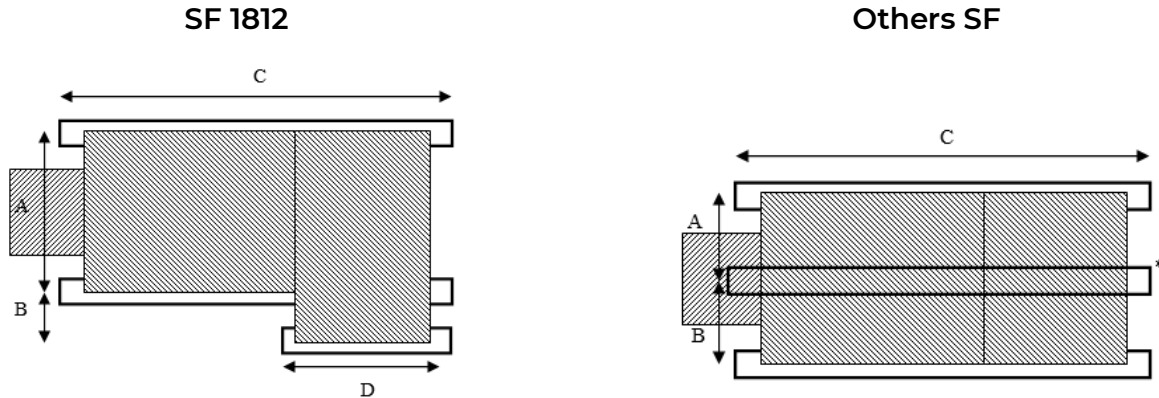

	Qty	Distance between beams under the basin A [mm]	Distance between beams under the basin B [mm]	Length superior to C [mm]	Length superior to D [mm]
SF 1812	3	1 330	295	3 500	1 600
SF 2415	2	1 630		4 200	
SF 2718	3	926,5	926,5	4 500	
SF 3021	3	1 115	1 115	4 800	

Quantity and position of concrete or metallic beams (customer supply) for cooling towers with IB sound attenuation

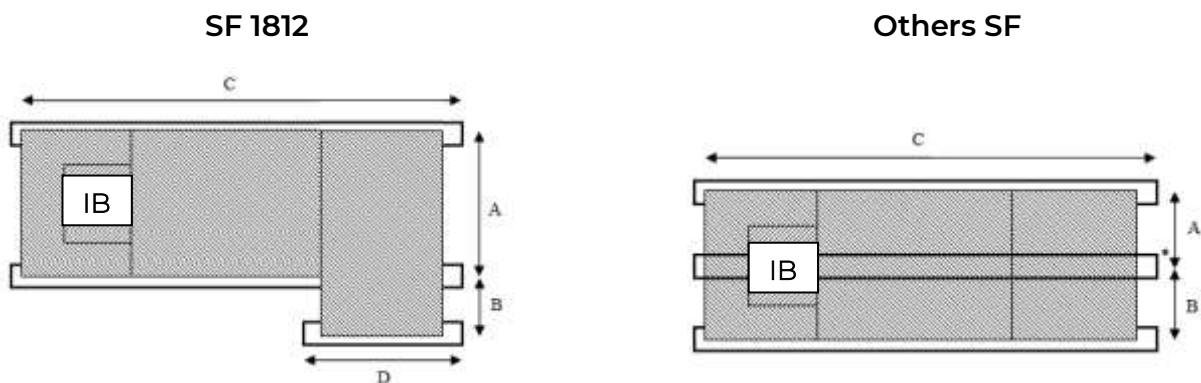

	Qty	Distance between beams under the basin A [mm]	Distance between beams under the basin B [mm]	Length superior to C [mm]	Length superior to D [mm]
SF 1812	3	1 330	295	5 300	1 600
SF 2415	2	1 630		6 200	
SF 2718	3	926,5	926,5	6 800	
SF 3021	3	1 115	1 115	7 350	

Support SFIM

SFIM cooling tower ranges can stand on a concrete base or on steel frame beams (customer supply). Check that the ground can stand the operating load, and that surface or supports are flat and horizontal.

Quantity and position of concrete or metallic beams (customer supply) for cooling towers without sound attenuation

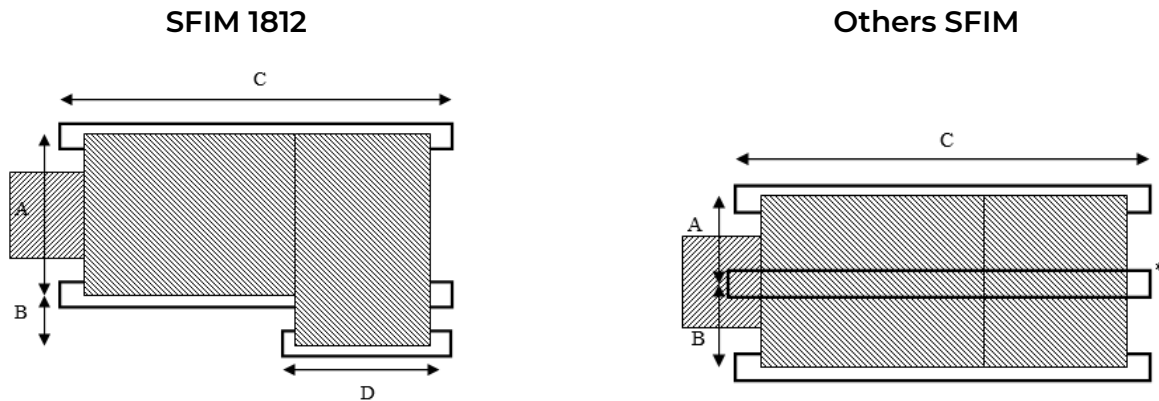

	Qty	Distance between beams under the basin A [mm]	Distance between beams under the basin B [mm]	Length superior to C [mm]	Length superior to D [mm]
SFIM 1812	3	1 330	295	3 500	1 600
SFIM 2415	2	1 630		4 200	
SFIM 2718	3	926,5	926,5	4 500	
SFIM 3021	3	1 115	1 115	4 800	

Quantity and position of concrete or metallic beams (customer supply) for cooling towers with IB sound attenuation

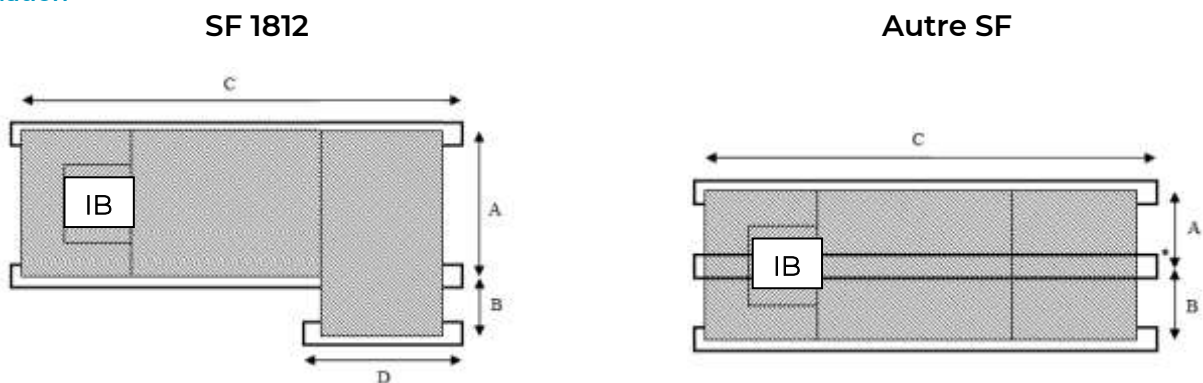

	Qty	Distance between beams under the basin A [mm]	Distance between beams under the basin B [mm]	Length superior to C [mm]	Length superior to D [mm]
SFIM 1812	3	1 330	295	5 300	1 600
SFIM 2415	2	1 630		6 200	
SFIM 2718	3	926,5	926,5	6 800	
SFIM 3021	3	1 115	1 115	7 350	

On site Layout SF - SFIM

Walls, higher or equal to the tower must not surround on all sides a cooling tower, furthermore without any openings. This could create a risk of a « re-circulation »; the air discharged (hot and saturated) may be recycled into the unit and significantly reduces the thermal efficiency of the tower.

In any case, the free access on the four sides of the tower must be secured to ensure that the fans are supplied correctly with air and that there is proper access for installation and maintenance. If these rules are not applied, it is inevitable that the cooling tower will not operate properly.

Recommended minimum free access (mm) for standard cooling towers: Top view

Cooling tower without sound attenuation

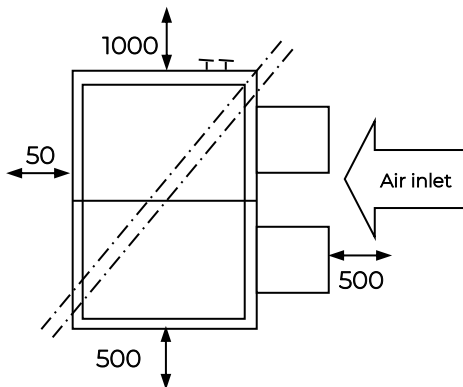

Sound attenuated cooling tower

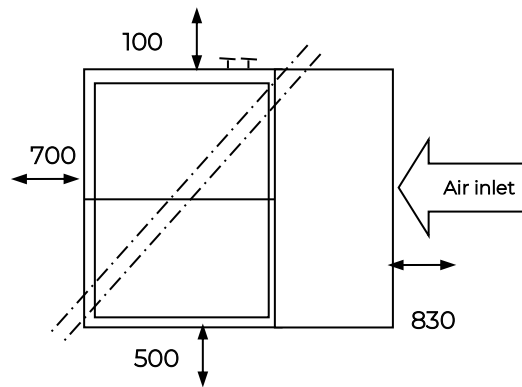

Do not hesitate to contact us for any advice

Layout examples:

NO

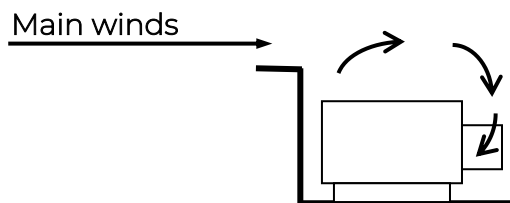

YES

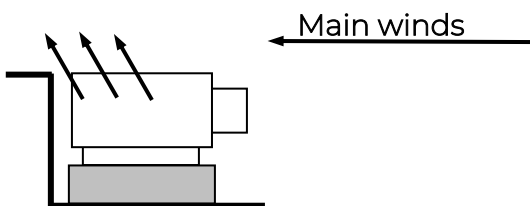

Install a base in order to up the cooling tower

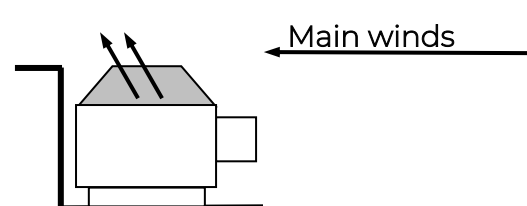

Install a cone in order to up the air outlet of the cooling tower

Water treatment SF – SFIM

WATER EVAPORATION

Consumption by evaporation is approximately 1.7 kg/h per 1 000 kcal/h.

DECONCENTRATION

Due to the evaporation and to the water recycling, impurities or salts in the water are concentrated. To make sure that this concentration is not too high, drain must be carried out.

If not, concentration rates of 10, 100 or even 1,000 would occur over time.

In order to pre-determine the installation requirements, consider drain value twice the evaporation level. In operation, with an efficient water treatment, this figure may decrease, especially in the case of a stainless-steel cooling tower (concentration rate of 3 to 5 possible).

There are three possibilities to choose according to the case:

1- Continuous blow down

Connection piece to be installed at the pump discharge just before the tower, if possible, at the level of the water distribution pipes so that the purge only takes place when the circulation pump is operating.

The blow down flow rate can be calculated using the formula: $100 S / (M - S)$ % of the make-up water in which:

S: Salinity of the make-up water compensating for evaporation.

M: Maximum acceptable salinity level of water in circuits.

Example:

Salinity of make-up water = HT 20 ° F

Maximum acceptable salinity = HT 40 ° F

$100 \times 20 / (40 - 20) = 100$ % make-up water flow rate

Therefore, the continuous blow down must be equal to the evaporated make-up water flow rate (rate=2).

Consequently, the real water consumption is twice the theoretical evaporated water flow.

2- Discontinuous blow down

The conductivity of the water in the circuit is controlled and the device is purged while not exceeding the TH value.

3- JACIR Automated Inductive Blow down

Once water conductivity level has been reached, a motorised valve can be activated to drain the required quantity of water to maintain the right concentration level. See separate documentation.

WATER TREATMENT

It is essential that good quality water is available to ensure that the closed-circuit cooling network operates correctly. If the water contains a significant amount of impurities, it is recommended that a filtration device to be installed in parallel for 5 to 10 % of the recycled water flow.

If the water contains salts that form deposits, iron or corrosive chemical elements, a make-up water treatment system must be installed to obtain purer water, which is close to being chemically neutral, and which can supply the cooling devices without causing damage.

In some cases, algae, moss, fungus or permanent shells can tend to grow in cooling towers. There are products that can be added periodically to the water circuit to prevent these organisms from developing.

Water treatment should be undertaken by a specialized Company.

PREVENTS THE RISK OF LEGIONNAIRES' DISEASE: See separate documentation.

Prescription SF

Evaporative cooling tower, high efficiency closed circuit with forced centrifugal fans, **SF**
JACIR type, designed for a glycol free operation during freezing period.

The system will be with a double exchange: a direct exchange air/ water, and an exchange water/ water, both counter flow types.

The cooling tower will be designed and delivered by the supplier, totally assembled on frame, exchanger, pump and technical accessories gathered in a same technical area with large access door.

Thermal characteristics

The dissipated power will be.... kW, with a temperature range from°C to°C, an ambient air temperature of ...°C, and a wet bulb temperature of..... °C.

Sound level characteristics

The sound pressure level will not exceed... dB (A) at meters in free field over 4 directions. To ensure this, the tower has one of the following types of soundproofing devices:

1 – **IB option** with sound attenuators without baffles at air inlet, and outlet cone coated with acoustic foam.

2 – **ICV – ICVK or Special** sound attenuation with parallel baffles both at air inlet and outlet, equipped with 50mm thick high density rock wool double casing, covered by 1.2 mm thick steel sheet. NR30 at 10m may be reached.

I – WATER – AIR EXCHANGE: COOLING TOWER CIRCUIT

Tower casing, sloped and plane bottom basin

The cooling tower casing will be made of self-supporting steel panels, twice or 4 times folded on the 4 sides. Side panels will be designed to receive if necessary, a double casing later on. Stainless steel rivets with uniform and high-capacity locking will be used for assembly.

The cooling tower casing will be assembled without any bolting or welding for the parts in contact with water; a special designed high covering seal ensure waterproofing between the panels.

The basin will be equipped with a rectangular access door (390 x 540 mm), with a floating valve that can easily be adjusted, a drain, an overflow and an anti-cavitation strainer.

The sloped bottom of the basin will allow a complete and easy drain thanks to the (POWER FLOW) drain hole located under the lowest part of the basin in order to ease the cleaning. The size of this opening will be 260x110 mm. Height between basin bottom and the infill is 1400 mm for easy access.

Casing structure

The cooling tower panels casing will be made of:

- ∞ As a standard, galvanized steel 2 mm thick ZENDZIMIR process 275 gr/m² or;
- ∞ Option, X-STEEL stainless steel (corrosion resistance higher than 316L) for its long-lasting properties, water saving and easy cleaning.

Accessibility

As a standard, the basin will be delivered with access door(s) sized 390 x 540 mm, and a POWER FLOW access 260 x 110 mm allowing express draining and cleaning of sludge or other accumulated parts of the bottom casing using simple water jet.

A large door sized 1290 x 640 mm in the same material as the cooling tower casing will also be provided, and will allow quick removing of the drift eliminators, the nozzles, the packing (infill) and the water distribution pipes.

Filtration

Located at the outlet of the basin, a 5 mm strainer will be installed and a FRC centrifugal filter made of the same material as the piping (galvanized steel, or 304-316L options) will be provided before the plate heat exchanger.

The centrifugal FRC filter will offer the following characteristics:

- ∞ 100 % of the cooling tower flow will be filtered continuously every 1.2 minute: very high efficiency
- ∞ High efficiency at 60 µm for all elements with density superior to 1,
- ∞ Automatic cleaning during the blow down of water circuit.

The evaporative circuit will remain clean to avoid Legionella growth risk.

Fans

The low-pressure centrifugal fan(s) with forward-inclined blades and double air admission will be placed outside the basin in dry airflow and at man chest to access without disassembly.

The polyester inlet duct(s) stand out to optimise air suction will be simple to disassemble for easy maintenance.

The impeller is protected from corrosion by a baked epoxy coating. The elliptical scroll is made of X-STEEL stainless steel.

Optionally, the impeller can be made of stainless-steel.

Electric motor and coupling

The IE3 asynchronous three-phase motor(s) will be closed type ventilated case(s) with a power of maximum kW....., rpm, IP55 protected, class F/B. Coupling will be made of trapezoidal belts selected for 150 % of nominal power.

Water distribution

Water distribution will be made of PVC pipes through highly efficient polypropylene water distributors: the nozzles will distribute the water uniformly on the whole exchange surface and will be easily removable.

Exchange surface

Made of thermoformed and welded Polypropylene sheets, **EFFI-PACK** heat exchange surface will be resistant to chocks and will offer a large available surface. This system will ensure fouling risks reduction.

Drift eliminators

Highly efficient Eurovent certified, the PP sheets drift eliminators will prevent the water from being sprayed out at the outlet tower. Ultraviolet resistant, they will be easy to remove from the

top in order to access to the distributors and to the exchange surface if needed. The drift will be 0.01 % maximum of the re-circulating water flow.

II – WATER – WATER EXCHANGE: USER CIRCUIT

Integrated exchanger room

The stainless-steel plate heat exchanger will be imperatively protected from conditions weather in its dedicated room: self-supporting galvanized structure (20/10e minimum) paint coating as a standard. This integrated exchanger room with removable panels for easy maintenance will be equipped with a large access door sized 2400 x 850 mm as a standard.

The plate heat exchanger connection will be provided outside the room by 2 flanges.

The plate heat exchanger will be equipped with gaskets and symmetric plates.

Life freezing damage free guarantee, even with the use of non-glycol water.

Connections

A stainless-steel strainer and a cleanable filter (on large size exchanger room only) will secure the proper water filtration before the inlet to the plate heat exchanger. The water circulation inside the system will be secured by a pump. This pump will be protected against freeze by a thermostatic valve.

All the connection pipes will be hot dip galvanized or in stainless steel option for optimized inside and outside protection. As standard, a low-level switch will avoid the start of the pump and will protect the water heaters in case of “too low” water level.

Pressure meters for control will be located before and after the pump, and before the water distribution header. They will secure a constant control of the system. A blow down hole with setting valve will be provided, and an electro valve as an option.

The servitudes panels will include a high-level switch, a drain hole and water make up.

Exchanger pump

Protected from freezing thanks to a patented thermostatic valve, the pump will not need any electrical tracing. A safety level switch will be provided to protect from cavitation.

Options

A water treatment may be integrated, as an option, as well as an integrated blow down (AID) inside in the exchanger room (see separate documentation).

Prescription SFIM

Evaporative cooling tower, high efficiency closed circuit with forced centrifugal fans, **SFIM**
JACIR type, designed for a glycol free operation during freezing period.

The system will be with a double exchange: a direct exchange air/ water, and an exchange water/ water, both counter flow types.

The cooling tower will be designed and delivered by the supplier, totally assembled on frame, exchanger, pump and technical accessories gathered in a same technical area with large access door.

Thermal characteristics

The dissipated power will be.... kW, with a temperature range from°C to°C, an ambient air temperature of ...°C, and a wet bulb temperature of..... °C.

Sound level characteristics

The sound pressure level will not exceed... dB (A) at meters in free field over 4 directions. To ensure this, the tower has one of the following types of soundproofing devices:

1 – **IB** option with sound attenuators without baffles at air inlet, and outlet cone coated with acoustic foam.

2 – **ICV** – **ICVK** or **Special** sound attenuation with parallel baffles both at air inlet and outlet, equipped with 50mm thick high density rock wool double casing, covered by 1.2 mm thick steel sheet. NR30 at 10m may be reached.

I – WATER – AIR EXCHANGE: COOLING TOWER CIRCUIT

Tower casing, sloped and plane bottom basin

The cooling tower casing will be made of self-supporting steel panels, twice or 4 times folded on the 4 sides. Side panels will be designed to receive if necessary, a double casing later on.

Stainless steel rivets with uniform and high-capacity locking will be used for assembly.

The cooling tower casing will be assembled without any bolting or welding for the parts in contact with water; a special designed high covering seal ensure waterproofing between the panels.

The basin will be equipped with a rectangular access door (390 x 540 mm), with a floating valve that can easily be adjusted, a drain, an overflow and an anti-cavitation strainer.

The sloped bottom of the basin will allow a complete and easy drain thanks to the POWER FLOW drain hole located under the lowest part of the basin in order to ease the cleaning. The size of this opening will be 260x110 mm. Height between basin bottom and the infill is 1400 mm for easy access.

Casing structure

The cooling tower panels casing will be made of:

- ∞ As a standard, galvanized steel 2 mm thick ZENDZIMIR process 275 gr/m² or,
- ∞ Option, X-STEEL stainless steel (corrosion resistance higher than 316L) for its long-lasting properties, water saving and easy cleaning.

Accessibility

As a standard, the basin will be delivered with access door(s) sized 390 x 540 mm, and a POWER FLOW access 260 x 110 mm allowing express draining and cleaning of sludge or other accumulated parts of the bottom casing using simple water jet.

A large door sized 1290 x 640 mm in the same material as the cooling tower casing will also be provided, and will allow quick removing of the drift eliminators, the nozzles, the packing (infill) and the water distribution pipes.

Filtration

Located at the outlet of the basin, a 5mm strainer will be installed and a FRC centrifugal filter made of the same material as the piping (galvanized steel, or 304-316L options) will be provided before the plate heat exchanger.

The centrifugal FRC filter will offer the following characteristics:

- ∞ 100 % of the cooling tower flow will be filtered continuously every 1-2 minute: very high efficiency
- ∞ High efficiency at 60 µm for all elements with density superior to 1,
- ∞ Automatic cleaning during the blow down of water circuit.

The evaporative circuit will remain clean to avoid Legionella growth risk.

Fans

The low-pressure centrifugal fan(s) with forward-inclined blades and double air admission will be placed outside the basin in dry airflow and at man chest to access without disassembly.

The polyester inlet duct(s) stand out to optimise air suction will be simple to disassemble for easy maintenance.

The impeller will be protected from corrosion by a baked epoxy coating. The elliptical scroll will be made of X-STEEL stainless steel.

Electric motor and coupling

The IE3 asynchronous three-phase motor(s) will be closed type ventilated case(s) with a power of maximum kW....., rpm, IP55 protected, class F/B. Coupling will be made of trapezoidal belts selected for 150 % of nominal power.

Water distribution

Water distribution will be made of PVC pipes through highly efficient polypropylene water distributors: the nozzles will distribute the water uniformly on the whole exchange surface and will be easily removable.

Exchange surface

Made of thermoformed and welded Polypropylene sheets, EFFI-PACK heat exchange surface will be resistant to chocks and will offer a large available surface. This system will ensure fouling risks reduction. The Infill will have an excellent high temperature and chemical agents' resistance, and easy maintenance.

Drift eliminators

Highly efficient Eurovent certified, the PP sheets drift eliminators will prevent the water from being sprayed out at the outlet tower. Ultraviolet resistant, they will be easy to remove from the top in order to access to the distributors and to the exchange surface if needed. The drift will be 0.01 % maximum of the re-circulating water flow.

Non-freezing plume suppression coil and modulating valve (JACIR patent)

As a standard model, the stainless-steel headers will be totally removable for access and complete cleaning. This “cover” type configuration will protect the coil from accidental damage related to possible freeze-over. Two air vents will secure the freezing risk. The tubes will be assembled in a triangular pitch, in copper outside diameter 12 mm, and 0.5 mm thick. The fins will be in copper.

A monitored valve adjusting the water flow sprays over the infill, will be associated to the plume coil.

II – WATER – WATER EXCHANGE: USER CIRCUIT

Integrated exchanger room

The stainless-steel plate heat exchanger will be imperatively protected from conditions weather in its dedicated room: self-supporting galvanized structure (20/10e minimum) paint coating as a standard. This integrated exchanger room with removable panels for easy maintenance will be equipped with a large access door sized 2400 x 850 mm as a standard.

The plate heat exchanger connection will be provided outside the room by 2 flanges.

The plate heat exchanger will be equipped with gaskets and symmetric plates.

Life freezing damage free guarantee, even with the use of non-glycol water.

Connections

A stainless-steel strainer and a cleanable filter (on large size exchanger room only) will secure the proper water filtration before the inlet to the plate heat exchanger. The water circulation inside the system will be secured by a pump. This pump will be protected against freeze by a thermostatic valve.

All the connection pipes will be hot dip galvanized or in stainless steel option for optimized inside and outside protection. As standard, a low-level switch will avoid the start of the pump and will protect the water heaters in case of “too low” water level.

Pressure meters for control will be located before and after the pump, and before the water distribution header. They will secure a constant control of the system. A blow down hole with setting valve will be provided, and an electro valve as an option.

The servitudes panels will include a high-level switch, a drain hole and water make up.

Exchanger pump

Protected from freezing thanks to a patented thermostatic valve, the pump will not need any electrical tracing. A safety level switch will be provided to protect from cavitation.

Options

A water treatment may be integrated, as an option, as well as an integrated blow down inside in the exchanger room (see separate documentation).