

DTC



Open cooling towers

CONTENTS	Page(s)
Operating principle	2
General description and benefits DTC range	3
Manufacturing details - Options	4-9
Technical characteristics – Weights and dimensions DTC	10
Drawings DTC without sound attenuation – 2/4/6 and 1/3/5/7 MFU	11-12
Drawings DTC with IB sound attenuation – 2/4/6 et 1/3/5/7	13-14
Drawings DTC with ICV sound attenuation – 2/4/6 et 1/3/5/7	15-16
On site layout	17
Choice of location	18
Water treatment	19
Technical prescription DTC	20-21

Technical Documentation



Operating principle DTC

Operating principle

A water-cooling tower with an innovative design that complies with and is even ahead of December 2020 NF E 38-424 standard: the extremely quiet "Plug and Play" centrifugal fans suck in the air to cool the water distributed optimally over the exchange surface. Entirely designed to ease maintenance thanks to its integrated technical room, the DTC is a concentrate of energy efficiency, even in cases where space is limited: it can be installed in a corner.

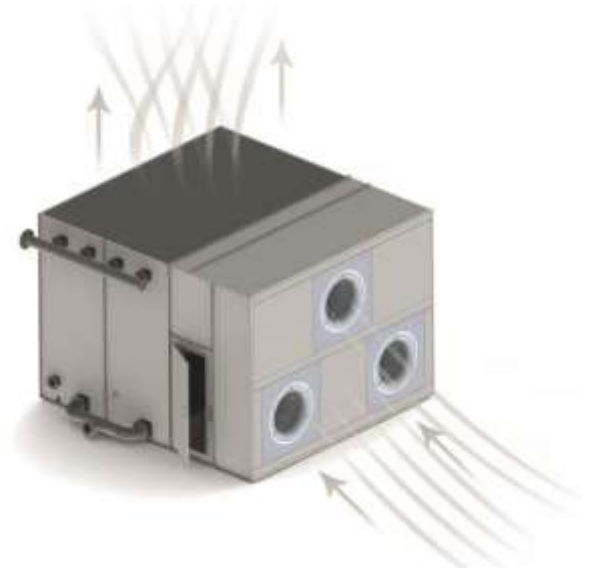

Operation of an open wet air cooler

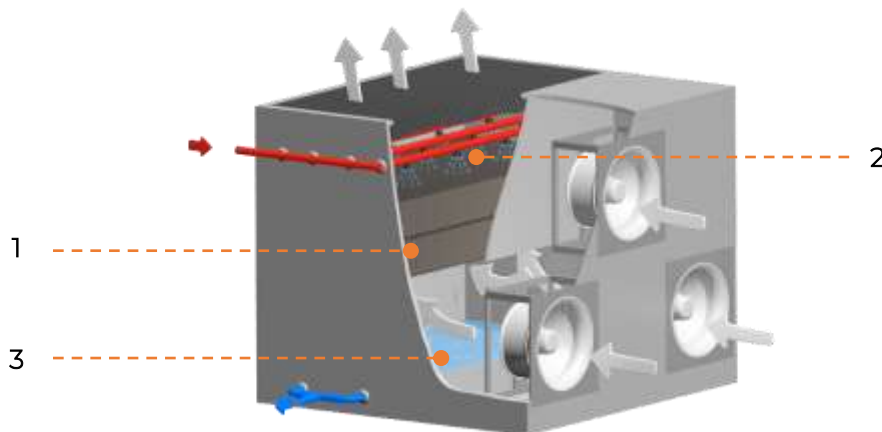

The hot water to be cooled is pumped to the top of the cooler through a pipe and then distributed over the heat exchange surface (1) by distribution nozzles (2).

Blown by the fans fresh air enters the lower section of the cooler and moves out through the upper section after heating up and saturation by passing through the heat exchange surface. Because of the superficial tension created by the exchange surface, the water evenly flows down along the whole height of the tower. The exchange surface is thus increased.

Cooled by forced ventilation, the water falls by gravity into the inclined basin (3) located at the bottom of the tower.

General description and benefits DTC range

General description

The DTC cooling tower is composed of 2 perfectly sealed, assembled casings:

- ∞ One casing dedicated to water circulation: water distribution, packing, basin and its accessories,
- ∞ One casing dedicated to airflow circulation, equipped with a maintenance corridor running along the entire width of the tower.

Each tower is equipped with:

- ∞ An ultra-quiet highly power efficient EC motors: 64 dBA at 3 meters for 1.2 MW,
- ∞ Centrifugal jet fans (world first),
- ∞ A hygienic basin whose sloping and flat bottom allows easy and total emptying thanks to Jacir **POWER FLOW** technology

Benefits of DTC serie

- ∞ **SAFETY and HYGIENE** Tower design compliant with NF E 38-424 and VDI 2047-2 standards relating to hygienic risks (legionellosis)
- ∞ **TIGHTNESS** Jacir jointing construction technology perfectly watertight.
- ∞ **SILENCE** Ultra-quiet towers in standard version achieving exceptionally low sound levels.
- ∞ **INFILL** Highly efficient, offering a wide exchange surface and temperature resistance
- ∞ **ANTICORROSION PROTECTION** The tower casing is assembled without welding, made in galvanized steel, or **X-STEEL** stainless-steel as an option (corrosion resistance higher than that of 316L)
- ∞ **EASY MAINTENANCE** Specially designed to ease maintenance:
 - ∞ Direct motor/fan coupling
 - ∞ An integrated access door leading to a technical room located between the wet section of the tower and the ventilation facilitates the maintenance operation, all at human height.
- ∞ **ELECTRICAL CONSUMPTION** Optimized power consumption per EC motor. Technology in compliance with Eco conception (UE) 327/2011 concerning Directive 2009/125/CE application (ErP) for minimum efficiency thresholds after 2015.
- ∞ **EVOLUTIVE TOWER** Possibility to upgrade the equipment to a closed-circuit and additional soundproofing
- ∞ **MODULAR CONSTRUCTION** Easy transport and handling

Manufacturing details - Options

Tower casing

Self-supporting stiff panels, with double or quadruple folds on all four sides of the panel (Jacir design) allowing the body tower soundproofing if needed. Thanks to this technology we can offer towers with an extremely low sound level.

The tower is assembled with waterproof stainless-steel rivets (tightness and uniformity of clamping). Neither welding nor screws are used for panel's assembly for sections in contact with water; a specially designed seal provides the water tightness between panels.

DTC range cooling towers is designed for an optimized transport and final assembly of its 2 modules.



As standard, the panels are made of 2mm thick galvanised sheet, ZENDZIMIR process at 275 gr/m² (the protection of the galvanised sheets is ensured by formation of zinc oxidation on the surface).

As an option, X-STEEL stainless-steel (corrosion resistance superior to 316L) is proposed, either for airflow circulation casing, or for water circulation casing, or both casings.

Material for the hydraulic connections is similar to the one chosen for water circulation casing.



Inclined and flat bottom Basin

The large capacity basin's able to adapt the response time of the facility. Its sloping and flat bottom allows **easy and total draining**. Easily accessible through the integrated technical corridor with its dedicated access door.



The basin includes:

- ∞ An easily adjustable float valve,
- ∞ An overflow,
- ∞ An anti-freeze resistance, as an option: in 230V or 400V and waterproof thermostat with separate bulb,
- ∞ A drain opening and a **POWER FLOW** hatch below the low level of the basin to ease rapid removal of impurities during cleaning,
- ∞ A water outlet through removable strainer (stainless-steel or HDPE according to ND) with a large capacity flange witch suction design eliminates cavitation risk, and a filter,
- ∞ For the control of the resistor, proper contactors are necessary.



Heat exchange surface: EFFI-PACK

Made of thermoformed and welded polypropylene sheets, the **EFFI-PACK** exchange surface is shock-resistant and offers a **maximum exchange surface** with a large free surface area.

- ∞ good temperature resistance (75°C continuous),
- ∞ large surface area of high efficiency,
- ∞ ease of maintenance,
- ∞ high resistance to chemical agents,
- ∞ operating range up to 95°C on request (option)

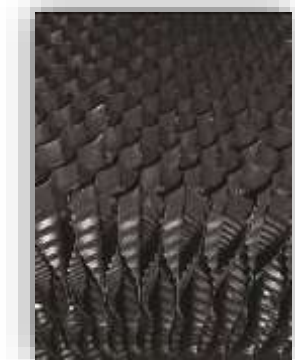

Water distribution

The water is distributed through PVC ramps equipped with highly efficient distributors distributing water in the form of a full jet cone. Screwed by wide clamps to distribution ramps, they can be easily dismantled while ensuring very good mechanical strength. An internal turbulator distributes the water evenly over the entire exchange surface.



Drift eliminators

Highly efficient, they prevent the water from being sprayed out of the tower. Ultraviolet rays resistant, they are easily removable from the top of the tower in order to access to the distributors and the exchange surface. The drift level is certified lower than 0.01% of the water flow. Drifts efficiency is certified by an independent party (EUROVENT).

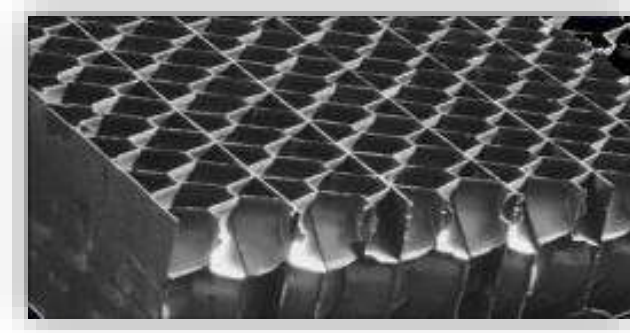

Tower design compliant with December 2020 NF E 38-424 and VDI 2047-2 standards relating to hygienic risks

Improved accessibility for maintenance: the technical room integrated into the tower offers total and immediate access to all its internal parts: drift eliminators, exchange surface, water distribution ramps, basin with its accessories, motors and fans: maintenance is simplified even in hydraulic operation.



« Plug fans » motor-fan set

Quiet, compact fans with EC motor integrated directly into the impeller. Extremely compact and silent jet fan units are equipped with EC motors directly integrated to the wheel with efficiency superior to IE4 class, without any use of rare-earths magnets. Fans are directly coupled to the motors.

EC motor with suction impeller on a single side permanently controlled by electronic commutation. The variation of the power electronics integrated in the EC motors is compatible with 380 à 480 V- IP 55.



Optional « Plug and Play » system for fan control.



The choice of this technology is in compliance with Eco conception (UE) 327/2011 concerning Directive 2009/125/CE application (ErP) for minimum efficiency thresholds after 2015.



Plume suppression coil (OPTION)

As standard, the battery consists of a steel manifold coated with a primary + epoxy paint. Two air vents ensure frost control. The tubes, arranged in a triangular pitch, are made of copper. As an option, they can be made of stainless-steel. The fins are made of copper or stainless-steel. The pitch is 3 mm as standard. A motorised valve which regulates the packing watering is coupled with the battery. Whenever weather conditions permit, this allows substantial water savings by evacuating heat thanks to the dry coil rather than by evaporation.



Automatic Inductive blow down (AiD)

Automatic Inductive blow down is available in option.

Sound attenuation (options)

IB sound attenuation

Sound trap in the fan box, between each fan, made of rock wool, glass veil and expanded metal in galvanized steel. An absorbent material will be deployed on the ceiling of the fan box.

Discharge sound trap made up of a soundproof cone making it possible to reduce the acoustic radiation surface.

Installed in the basin and on the opposite wall of the EFFI-SILENT system fan

ICV sound attenuation

Sound trap in the fan box, between each fan, made of rock wool, glass veil and expanded metal in galvanized steel. An absorbent material will be deployed on the ceiling of the fan box.

Discharge sound trap made up of a soundproof cone to reduce the surface area of acoustic radiation.

Installed in the basin and on the opposite wall of the EFFI-SILENT system fan. The casing, the fan box and the discharge box, consists of a box made of self-supporting rigid panels, double folded outwards on its 4 sides. The interior is lined with absorbent material and it contains sound traps with its acoustic baffles. The galvanized sheet baffles, made of high-density rock wool panels, are mounted on easily removable racks. On suction, the rock wool is protected by a glass veil. On delivery, the baffles receive protection reinforced by expanded metal in stainless-steel.



ICVK complete soundproofing with double tower body

The entire ICV version tower receives a lining made of high-density rock wool covered by an additional sheet: ICV-K.

OPTIONS

- ∞ Soundproofing: reinforced acoustics,
- ∞ **EFFI-SILENT** noise abatement for cooling towers basins,
- ∞ Plume suppression system,
- ∞ Exchanger room for closed circuit operation (**DTCF** range)
- ∞ **X-STEEL** stainless steel casing (higher corrosion resistance than 316L),
- ∞ Antifreeze heater with thermostat,
- ∞ Water supply by electric level control (with solenoid valve and filter),
- ∞ Automatic inductive blow down (see AID documentation),
- ∞ Air pressure available for duct connection,
- ∞ Material delivered in individual parts to be assembled,
- ∞ Assembly on site by our experienced technicians,
- ∞ Optional "Plug and Play" system: fan controls.

Technical characteristics DTC

DTC serie	Absorbed power [kW]*	Fans			Sound power without sound attenuation** [Lw]	Sound power with IB sound attenuation ** [Lw]	Sound power with ICV sound attenuation ** [Lw]
		Qty	Ø [mm]	Available power unit [kW]			
DTC-2315-PA-1-1000-64	470	1	1 000	6,4	89	81	74
DTC-2324-PA-2-1000-64	745	2	1 000	12,8	91	83	76
DTC-2336-PA-3-1000-64	1 115	3	1 000	19,2	92	85	77
DTC-2348-PA-4-1000-64	1 490	4	1 000	25,6	94	86	78
DTC-2360-PA-5-1000-64	1 860	5	1 000	32	95	87	79
DTC-2372-PA-6-1000-64	2 235	6	1 000	38,4	95	87	79
DTC-2384-PA-7-1000-64	2 600	7	1 000	44,8	96	88	80

* Data based on a thermal regime of 32/27/21°C

** +ou- 2dB(A)

Weights and dimensions DTC

DTC without sound attenuation	Motor Fan set Qty	Dimensions			Weight empty [Kg]	Weight in operation [Kg]	Water inlet [DN]
		Lenght (overall)	Width (overall)	Height (overall)			
DTC-2315-PA-1-1000-64	1	1 975	4 186	3 246	1 325	3 300	125
DTC-2324-PA-2-1000-64	2	2 775	4 186	3 246	2 035	5 122	150
DTC-2336-PA-3-1000-64	3	4 075	4 186	3 246	2 796	7 376	200
DTC-2348-PA-4-1000-64	4	5 275	4 186	3 246	3 557	9 621	250
DTC-2360-PA-5-1000-64	5	6 475	4 186	3 246	4 339	11 885	250
DTC-2372-PA-6-1000-64	6	7 675	4 186	3 246	5 121	13 880	300
DTC-2384-PA-7-1000-64	7	8 875	4 186	3 246	5 903	16 098	300

DTC IB serie	Motor Fan set Qty	Dimensions			Weight empty [Kg]	Weight in operation [Kg]	Water inlet [DN]
		Lenght (overall)	Width (overall)	Height (overall)			
DTC-2315-PA-1-1000-64	1	1 975	4 186	4 246	1 528	3 503	125
DTC-2324-PA-2-1000-64	2	2 775	4 186	4 246	2 399	5 486	150
DTC-2336-PA-3-1000-64	3	4 075	4 186	4 246	3 232	7 812	200
DTC-2348-PA-4-1000-64	4	5 275	4 186	4 246	4 171	10 235	250
DTC-2360-PA-5-1000-64	5	6 475	4 186	4 246	5 025	12 571	250
DTC-2372-PA-6-1000-64	6	7 675	4 186	4 246	5 986	14 745	300
DTC-2384-PA-7-1000-64	7	8 875	4 186	4 246	6 840	17 035	300

DTC ICV serie	Motor Fan set Qty	Dimensions			Weight empty [Kg]	Weight in operation [Kg]	Water inlet [DN]
		Lenght (overall)	Width (overall)	Height (overall)			
DTC-2315-PA-1-1000-64	1	1 975	4 950	4 746	1 874	3 849	125
DTC-2324-PA-2-1000-64	2	2 775	4 950	4 746	2 747	5 834	150
DTC-2336-PA-3-1000-64	3	4 075	4 950	4 746	3 726	8 306	200
DTC-2348-PA-4-1000-64	4	5 275	4 950	4 746	4 704	10 768	250
DTC-2360-PA-5-1000-64	5	6 475	4 950	4 746	5 703	13 249	250
DTC-2372-PA-6-1000-64	6	7 675	4 950	4 746	6 713	15 472	300
DTC-2384-PA-7-1000-64	7	8 875	4 950	4 746	7 713	17 908	300

Drawings DTC without sound attenuation – 2/4/6 Motor-fan sets

CH: WET CASING
CV: VENTILATION CASING

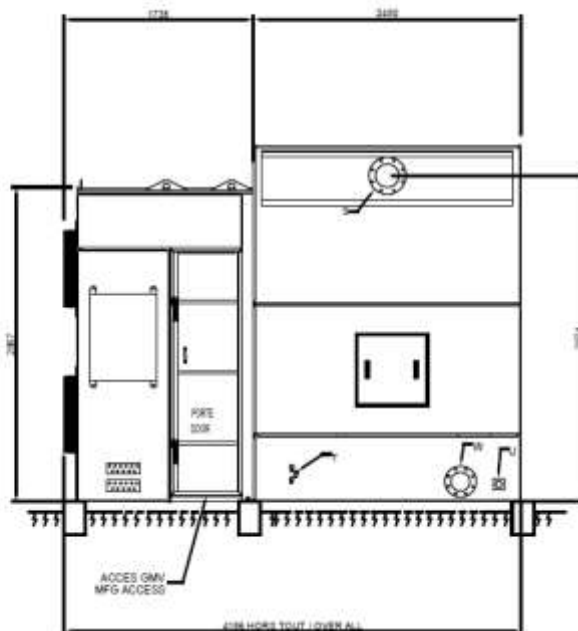
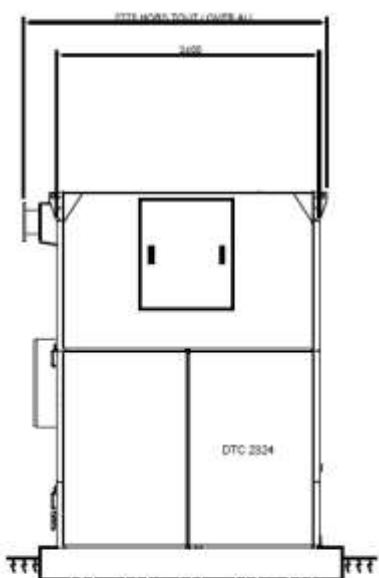
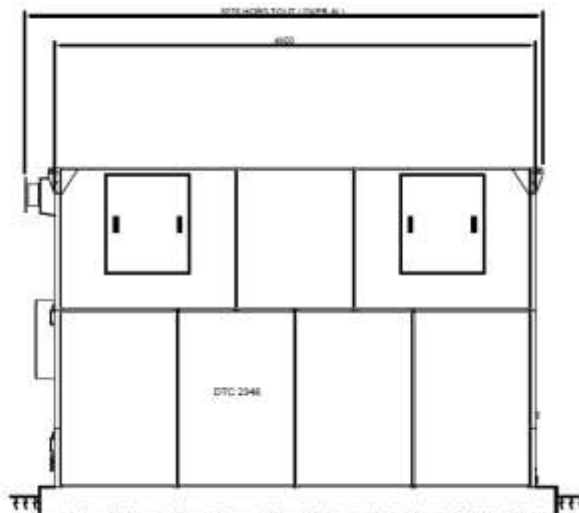
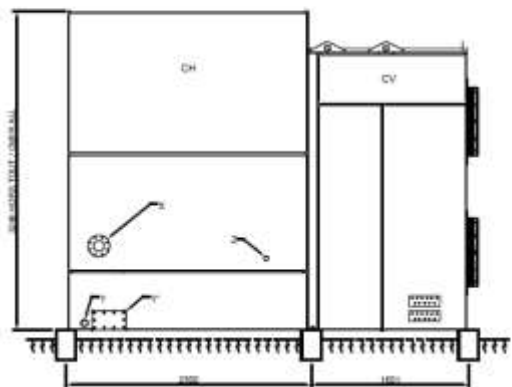

- S: HOT WATER INLET (ACCORDING FLOW RATE)
- T: WATER LEVEL CONTACTORS (OPTION)
- U: ANTI FREEZE RESISTOR (OPTION)
- W: COLD WATER INLET ND150 (ACCORDING FLOW RATE)
- X: OVERFLOW ND100 TURNING FLANGE PP PN16
- Y: DRAIN FEMAL ND50
- Y': POWER FLOW BASIN TRAP
- Z: WAKE UP WATER BY FLOATING TAP OR SOLENOID VALVE (OPTION)

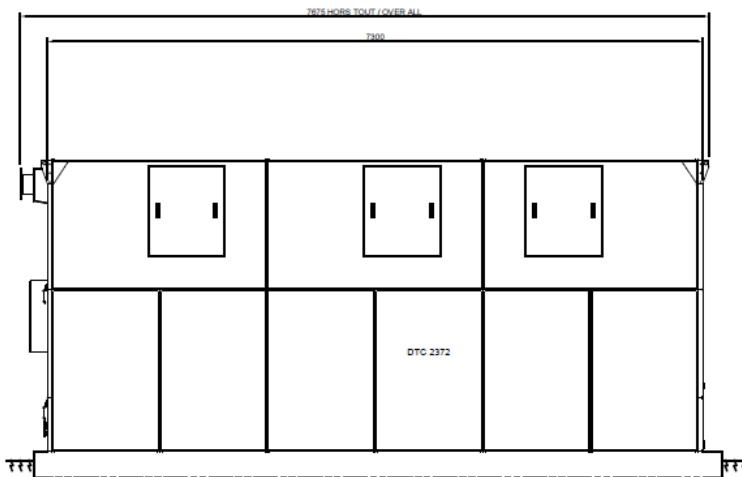
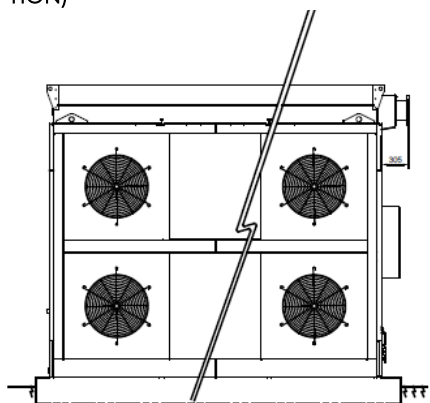

Drawings DTC without sound attenuation – 1/3/5/7 Motor-fan sets

CH: WET CASING
CV: VENTILATION CASING

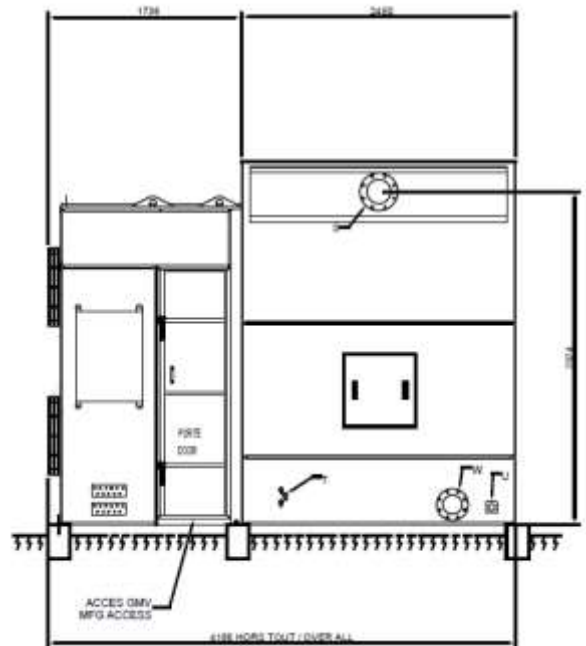
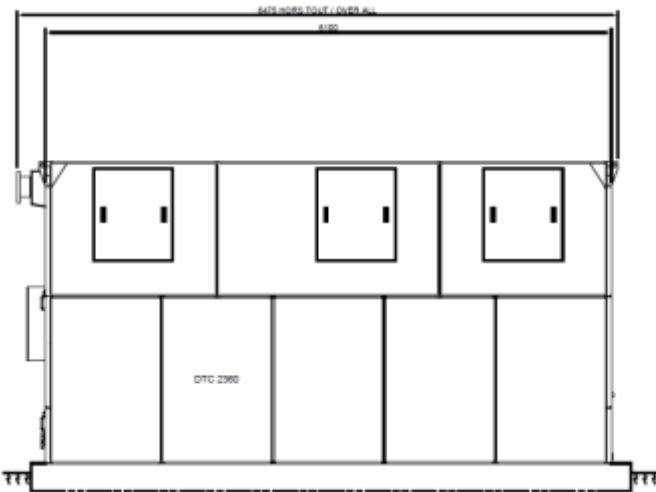
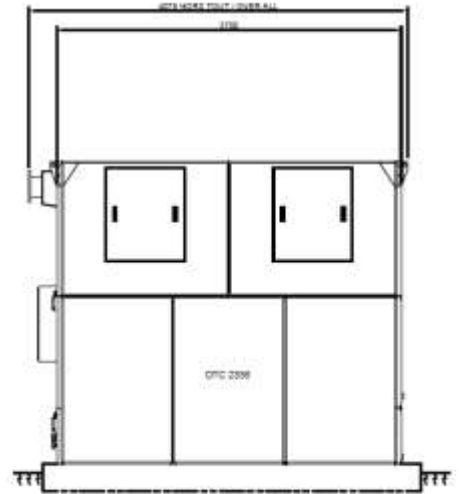
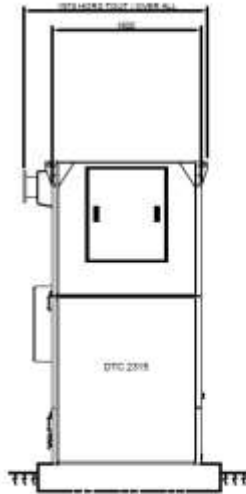
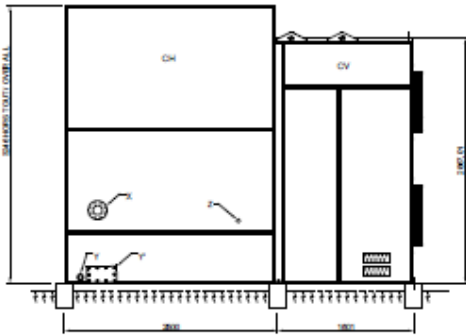

- S: HOT WATER INLET (ACCORDING FLOW RATE)
- T: WATER LEVEL CONTACTORS (OPTION)
- U: ANTI FREEZE RESISTOR (OPTION)
- W: COLD WATER INLET ND150 (ACCORDING FLOW RATE)
- X: OVERFLOW ND100 TURNING FLANGE PP PN16
- Y: DRAIN FEMAL ND50
- Y: POWER FLOW BASIN TRAP
- Z: WAKE UP WATER BY FLOATING TAP OR SOLENOID VALVE (OPTION)

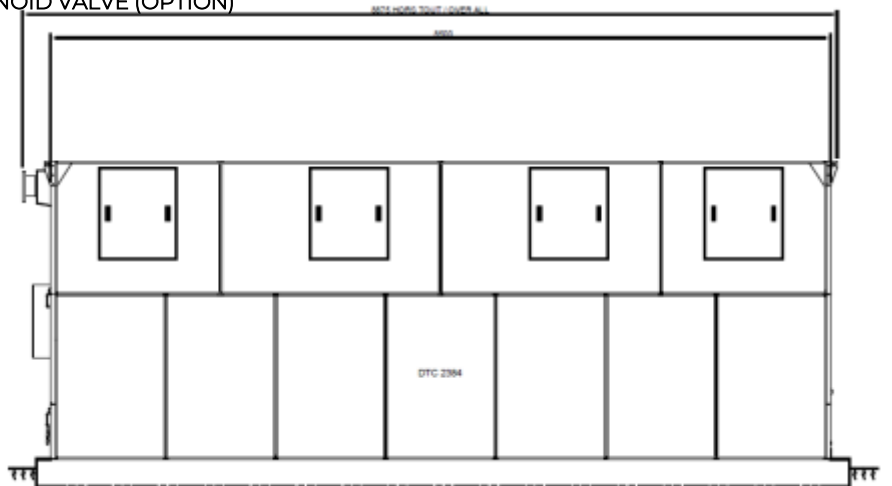
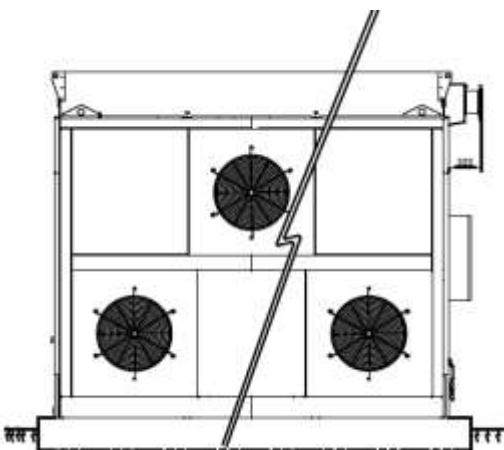

Drawings DTC IB sound attenuation – 2/4/6 Motor-fan sets

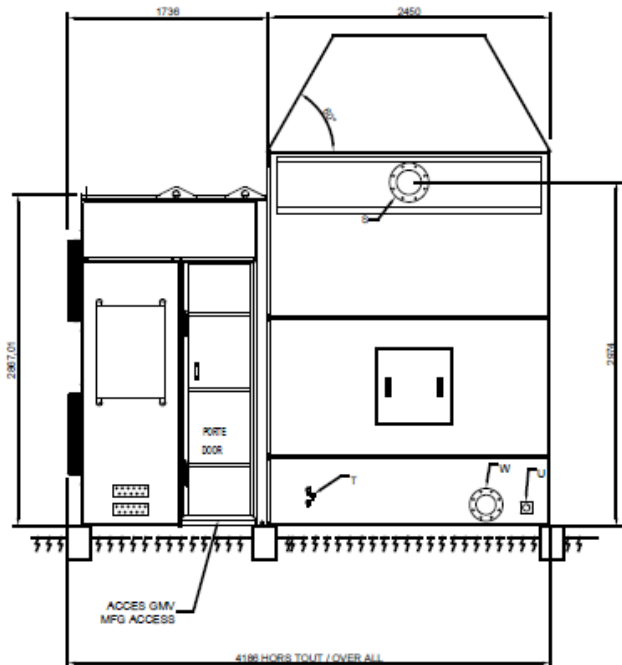
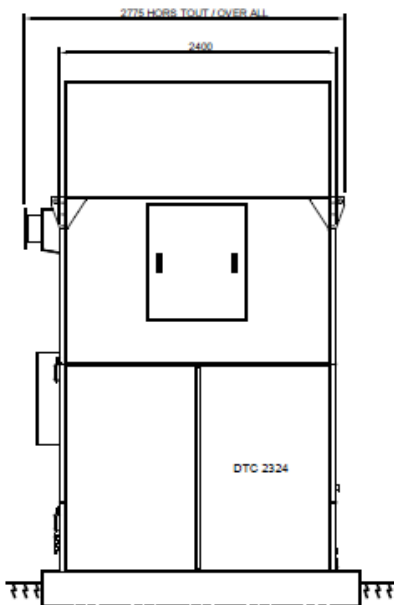
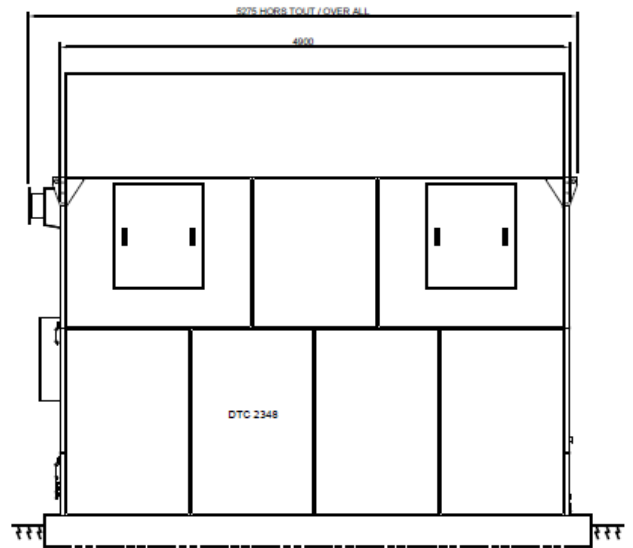
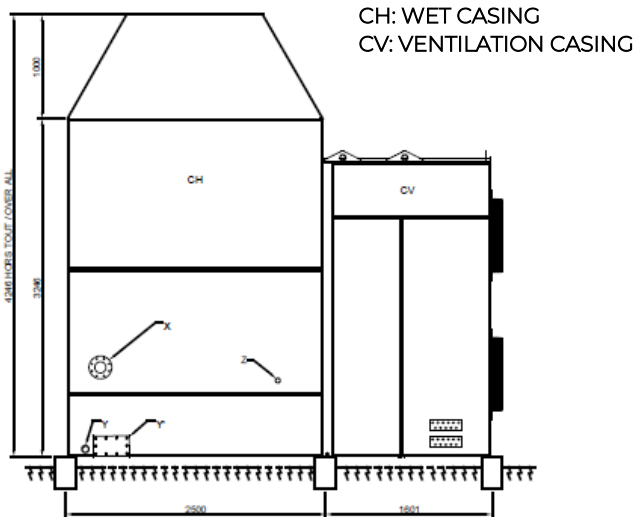

- S: HOT WATER INLET (ACCORDING FLOW RATE)
- T: WATER LEVEL CONTACTORS (OPTION)
- U: ANTI FREEZE RESISTOR (OPTION)
- W: COLD WATER INLET ND150 (ACCORDING FLOW RATE)
- X: OVERFLOW ND100 TURNING FLANGE PP PN16
- Y: DRAIN FEMAL ND50
- Y': POWER FLOW BASIN TRAP
- Z: WAKE UP WATER BY FLOATING TAP OR SOLENOID VALVE (OPTION)

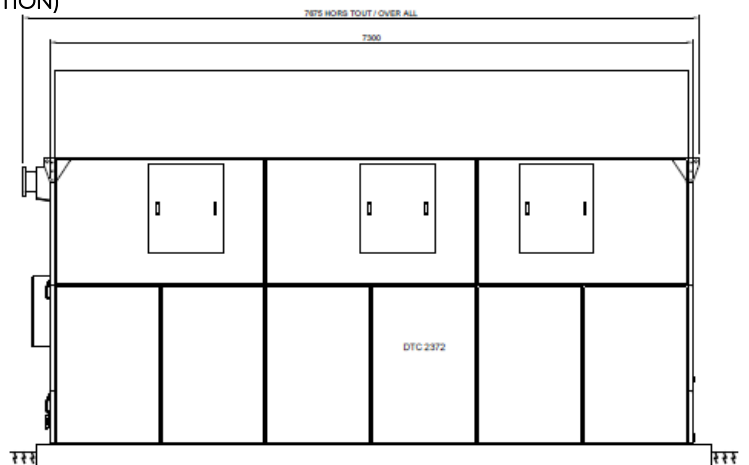
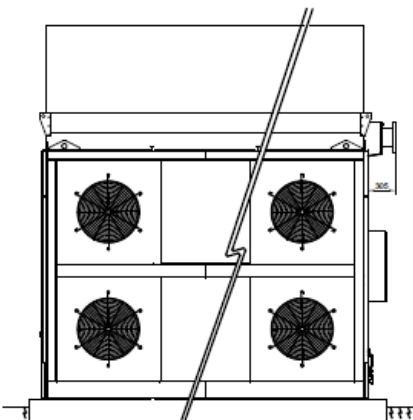

Drawings DTC IB sound attenuation – 1/3/5/7 Motor-fan sets

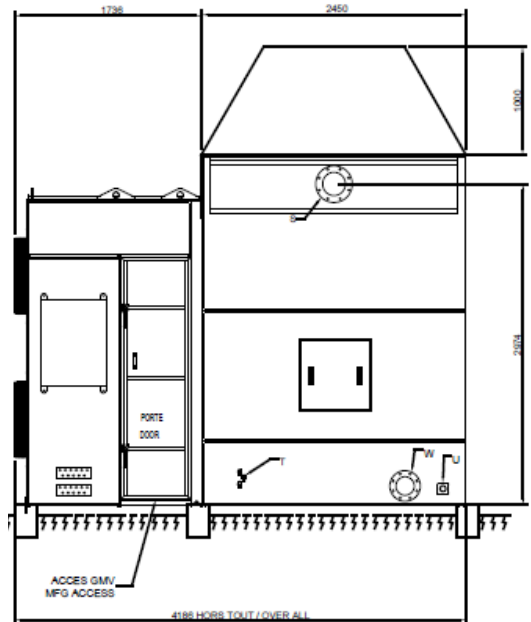
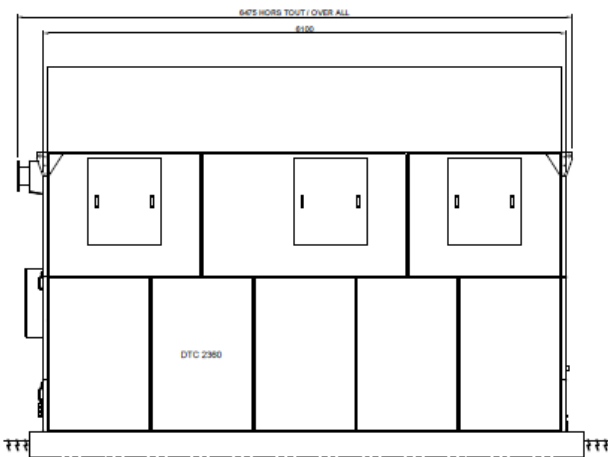
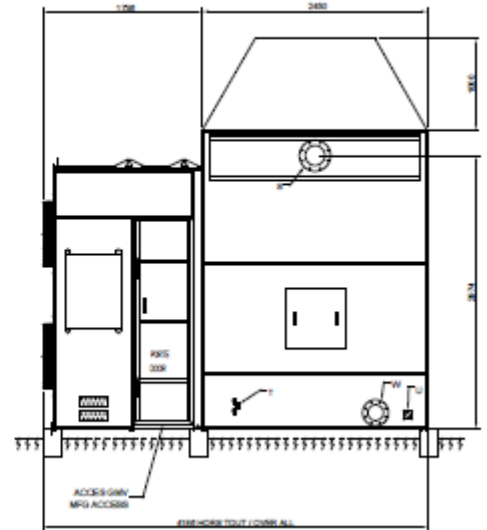
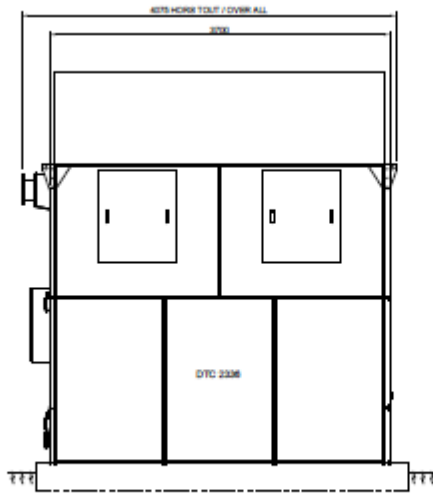
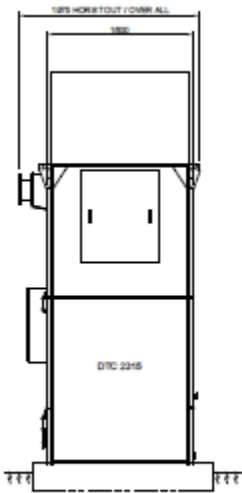

- S: HOT WATER INLET (ACCORDING FLOW RATE)
- T: WATER LEVEL CONTACTORS (OPTION)
- U: ANTI FREEZE RESISTOR (OPTION)
- W: COLD WATER INLET ND150 (ACCORDING FLOW RATE)
- X: OVERFLOW ND100 TURNING FLANGE PP PN16
- Y: DRAIN FEMAL ND50
- Y: POWER FLOW BASIN TRAP
- Z: WAKE UP WATER BY FLOATING TAP OR SOLENOID VALVE (OPTION)

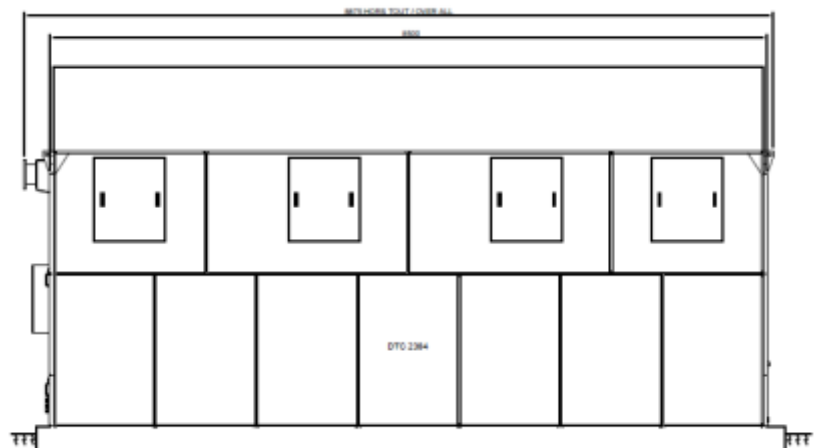
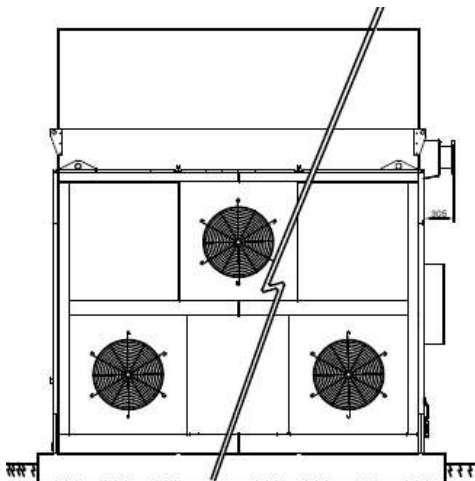

Drawings DTC ICV sound attenuation – 2/4/6 Motor-fan sets

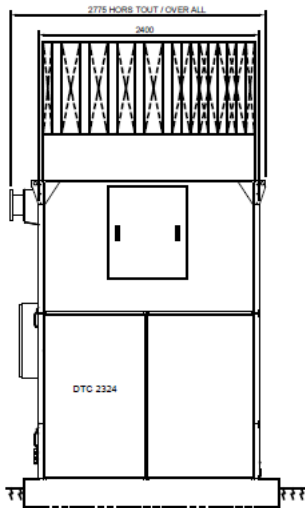

CH: WET CASING
 CV: VENTILATION CASING
 CBE: INLET BAFFLES CASING
 CBS: OUTLET BAFFLES CASING

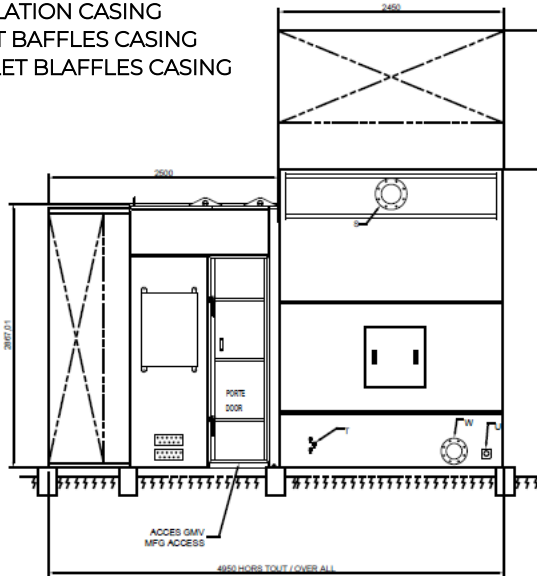

- S: HOT WATER INLET (ACCORDING FLOW RATE)
- T: WATER LEVEL CONTACTORS (OPTION)
- U: ANTI FREEZE RESISTOR (OPTION)
- W: COLD WATER INLET ND150 (ACCORDING FLOW RATE)
- X: OVERFLOW ND100 TURNING FLANGE PP PN16
- Y: DRAIN FEMAL ND50
- Y': POWER FLOW BASIN TRAP
- Z: WAKE UP WATER BY FLOATING TAP OR SOLENOID VALVE (OPTION)

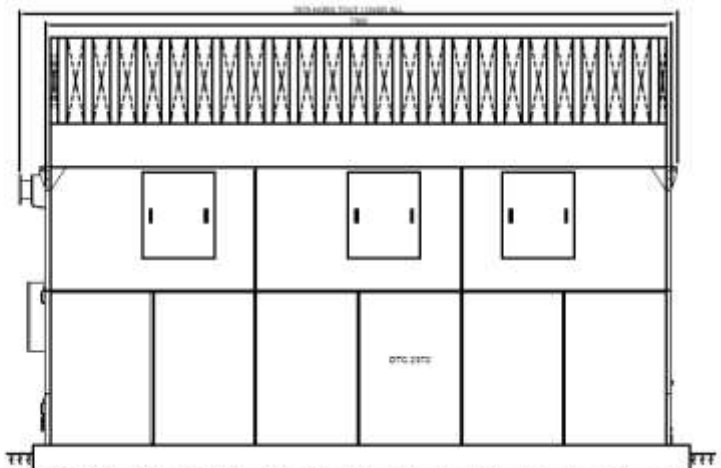
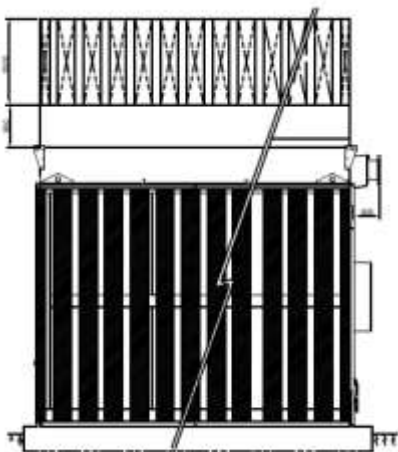
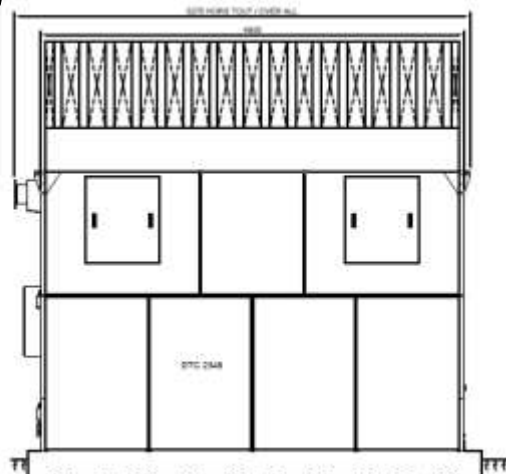
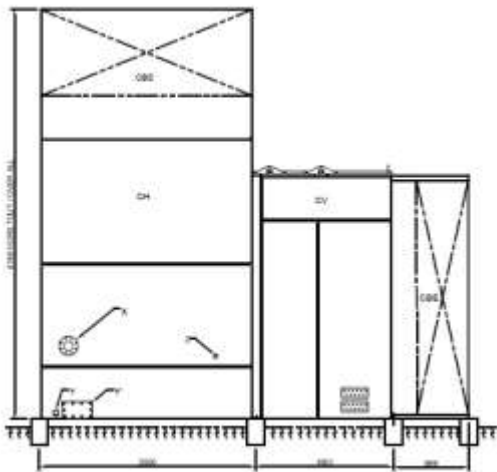

Drawings DTC ICV sound attenuation – 1/3/5/7 Motor-fan sets

CH: WET CASING
 CV: VENTILATION CASING
 CBE: INLET BAFFLES CASING
 CBS: OUTLET BAFFLES CASING

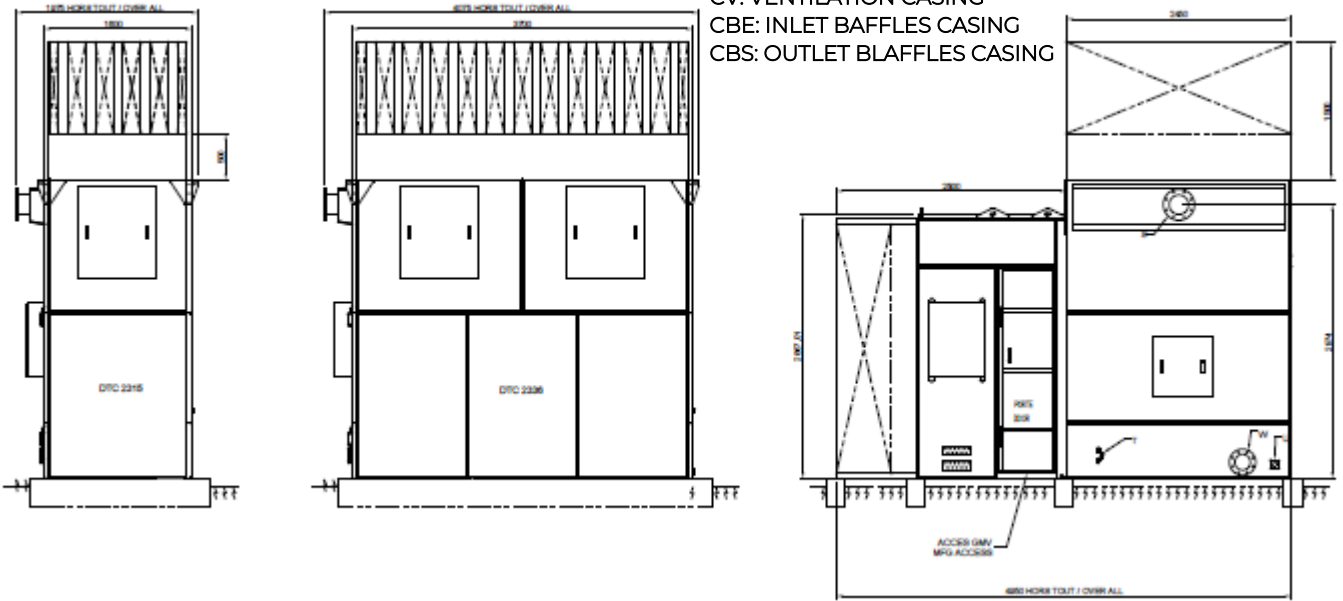

S: HOT WATER INLET (ACCORDING FLOW RATE)
 T: WATER LEVEL CONTACTORS (OPTION)
 U: ANTI FREEZE RESISTOR (OPTION)
 W: COLD WATER INLET ND150 (ACCORDING FLOW RATE)
 X: OVERFLOW ND100 TURNING FLANGE PP PN16
 Y: DRAIN FEMAL ND50
 Z: POWER FLOW BASIN TRAP
 (OPTION)

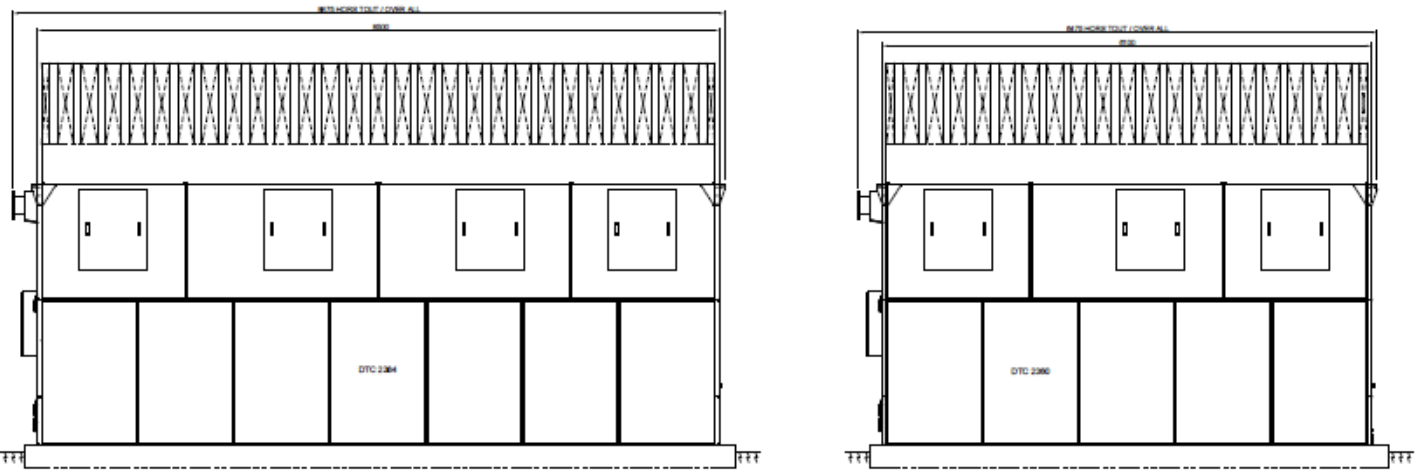
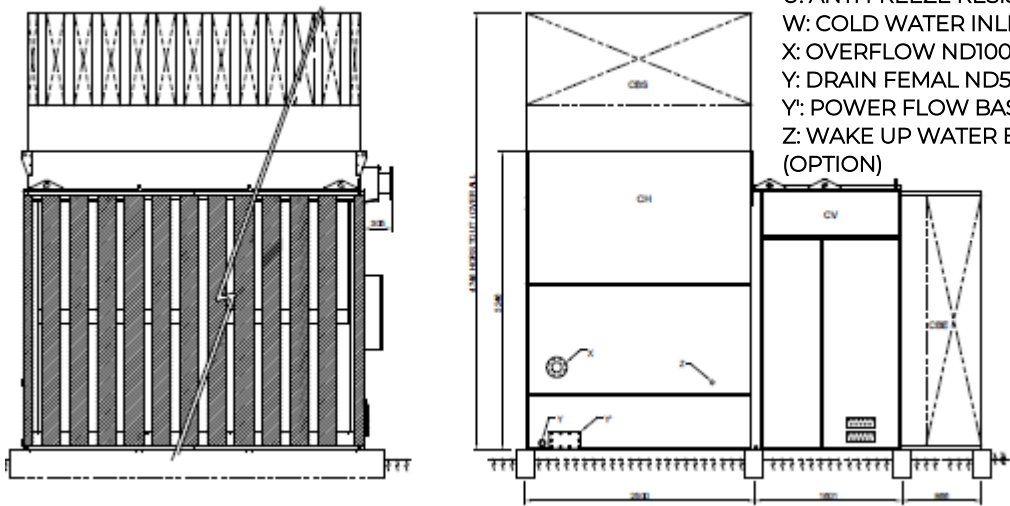

On site layout

Our cooling towers can stand on the ground or on a concrete floor base, but it is advisable to install them on concrete stringers or support irons (steel frame beams). Make sure that the floor receiving the cooling tower can support the load during operation and that the floor or supports form a correct plane.

Number and position of concrete beams or support bars (customer supply)

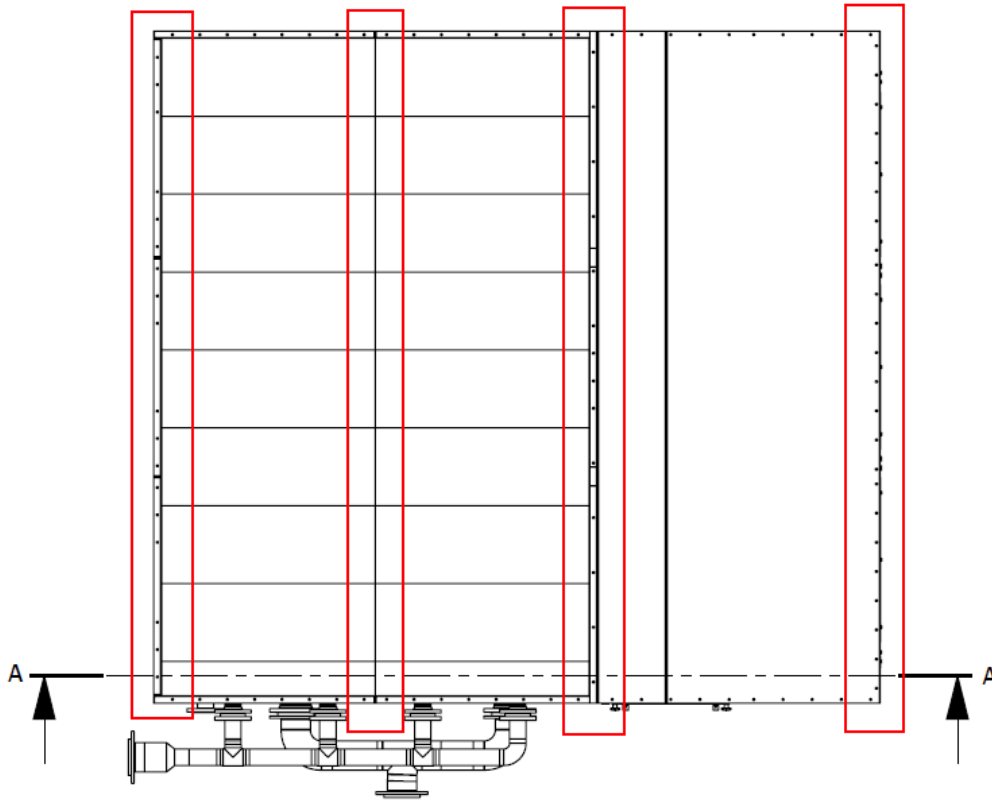

Choice of implantation DTC

The cooling tower must not be surrounded on all sides by walls higher or equal to its height, and moreover without an opening, because a "short circuit" risk could occur. The air discharged at the tower exit (hot, moisture-saturated air) could then be recycled into the unit and consequently reduce the thermal output of the tower.

In any case, you must respect minimum clearances around all four sides of the tower to ensure a correct air supply for fans and sufficient access for assembly and maintenance.

Failure to observe these rules would inevitably lead to a malfunction of the cooling tower.

Recommended minimum spacings in mm: diagram from above

Tower without sound attenuation

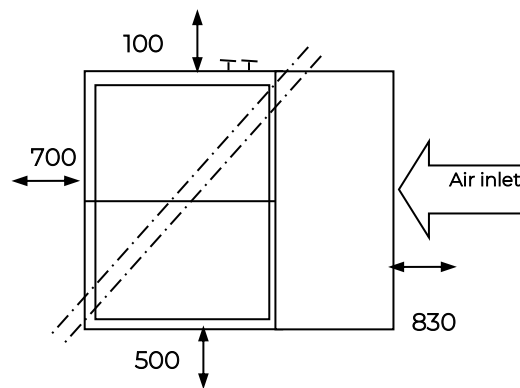

Please contact us for advice

Examples of implantation

The location choice for tower installation must follow these recommendations:

- ∞ The air intake area must always be kept free of any major obstruction.
 - ⇒ The obstacle-free distance to be kept around each air inlet is shown on the overall plan and is approximately 1 metre (unless otherwise stated)
- ∞ The air discharge must not be disturbed either by direct obstacles.
 - ⇒ The installation of acoustic baffles or ducts must be approved by JACIR's Technical Department.
- ∞ The risk of hot air being blown back (at tower outlet) to the air intake area must be prevented.
 - ⇒ The direction of the prevailing wind and the proximity of surrounding buildings (possibly generating risks of back-flow) are elements to be considered.

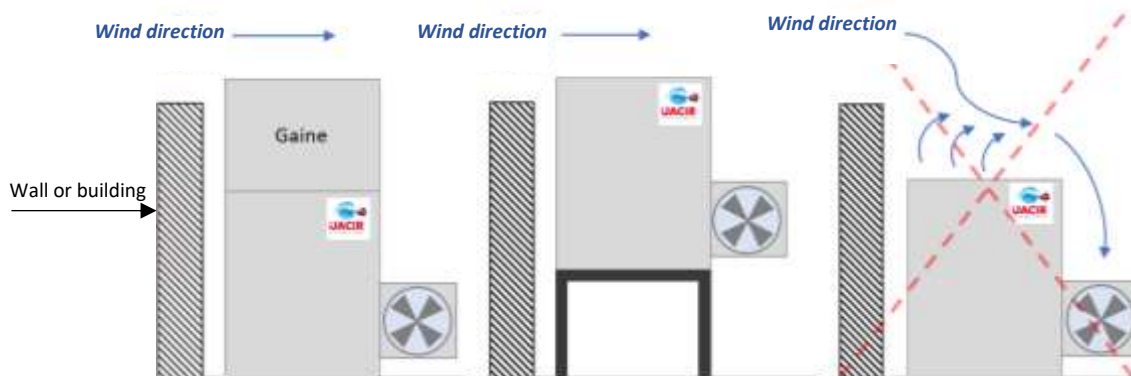

Water treatment DTC

WATER EVAPORATION

Consumption by evaporation is approximately 1.7 kg/h per 1,000 kcal/h.

DECONCENTRATION

Due to evaporation and water recycling, there is a concentration of impurities or salts in the water. To prevent it from exceeding a limit value deconcentration purges must be carried out.

Without this purging considerable concentration rates (Tx) of 10, 100, or even 1000 would occur over time.

For the pre-sizing of galvanized steel equipment, consider drain value of twice the evaporation level (Tx=2). For operation connected with a monitored water treatment this value may decrease, especially if the cooling tower casing is made of stainless-steel (rates of 3 to 5 possible).

Depending on the situation three deconcentration solutions can be sorted:

1- Continues purges

Connect to the pump outlet just before the tower, if possible, at the sprayer booms, so that the pump is only vented when it is running.

The flow rate for bleeding can be calculated by the formula: $[100 S / (M - S)] \%$ of the make-up water flow rate with:

S : Salinity of the make-up water compensating evaporation.

M : Maximum permissible salinity in the circuits.

Example:

Salinity of the make-up water = TH 20°.

Maximum permissible salinity = TH 40°.

$100 \times 20 / (40 - 20) = 100 \%$ of make-up water flow rate

So the continuous purge must be equal to the volume of water evaporated.

As a result, the actual make-up water flow rate is twice the theoretical evaporation flow rate.

2- Discontinuous purges

The water's conductivity in the circuit is checked and the system purged according to the value not to be exceeded.

3- Maintenance-free JACIR automated inductive deconcentration

Through conductivity measurement, it is possible to control a motorised valve which allows a flow to the sewer corresponding to the quantity of water necessary to maintain a correct concentration value (See separate document).

WATER TREATMENT

To ensure the proper functioning of a closed-circuit cooling system, it is essential to have good quality of water. If the water is contaminated with coarse impurities, it is recommended that 5-10% of the recirculated water flow should be filtered off in bypass. If the water contains encrusting salts or chemically aggressive elements, a make-up water treatment must be carried out to obtain a softer water close to chemical neutrality, capable of supplying the machines to be cooled without risk of damage.

In some cases, algae, mosses, fungi or shellfish may tend to grow in a cooling tower. There are products that, when added periodically to the circuit water, prevent the development of these organisms.

Water treatment should be entrusted to specialised companies.

LEGIONELLOSIS RISK PREVENTION: (see separate document).

Technical Prescription DTC

Highly energy-efficient open-circuit evaporative water-cooling tower with EC motors integrated in jet centrifugal fans the **JACIR DTC** range.....

EC motor with suction impeller on a single side will be permanently controlled by electronically commutation. Its efficiency will be really superior to IE4 efficiency class, without any use of rare Earths magnets.

The variation of the power electronics integrated in the EC motors will be compatible with 380 à 480 V- IP 55

The system will be double exchange based with a direct counter current air-water exchange system.

The tower will be designed and delivered by the manufacturer in two parts to be assembled with its integrated technical room equipped with a wide service door giving access to all its components.

Thermal characteristics

The power output will be ... kW for a speed from ...°C to ...°C with a wet suction temperature of ...°C.

The tower will have been the subject of a EUROVENT thermal performance certification.

Acoustic characteristics

The equipment sound pressure level must not exceed ... dB (A) at ... metres in open air in all four directions; thus, the tower must be equipped with sound reinforcement if necessary.

DIRECT AIR-WATER EXCHANGE: TOWER CIRCUIT Cooling Tower casing, sloped and plane bottom basin

The tower casing will consist of self-supporting steel panels twice or 4 times folded on the 4 sides. The side panels will be designed to receive later, if necessary, a doubling of the tower body. Stainless-steel rivets with high tightening capacity will be used for assembly. Concerning casing parts in contact with water they will be assembled without any bolting, welding or screwing and particular elastomer joints replacing jointing mastic will be of use for panel's watertight assembly.

The basin will include an easily adjustable float valve, an overflow, an anti-freeze resistance and an anti-cavitation filter strainer. The sloping bottom of the basin will allow an easy and total emptying: the lower location of the drain hole (POWER FLOW) below the low point of the basin's bottom. Access to power flow will be 260 x 100mm.

The large basin's capacity will increase inertia effect and system's water treatment efficiency.

Casing structure

The cooling tower panels structure will be made of:

- ∞ 2 mm thick galvanised sheet metal, Zendzimir process at 275 gr/m² or,
- ∞ **X-STEEL** stainless-steel for durability, water saving and cleanability.

Hydraulic connections material will be the same chosen for the water circulation casing.

Accessibility

As standard, a technical room integrated in the tower will offer total and immediate access to all internals: drip eliminators, exchange bodies, water distribution ramps, basin with its accessories, motors and fans providing simplicity for maintenance even under operation.

Motor-fan unit

Extremely compact and silent jet fan unit will be equipped with EC motors directly integrated to the wheel with efficiency superior to IE4 class. Fans will be directly coupled to the motors. The choice of this technology will be in compliance with Eco conception (UE) 327/2011 concerning Directive 2009/125/CE application (ErP) for minimum efficiency thresholds after 2015.

Water distribution

The water distribution will be provided by PVC ramps, equipped with easily removable polypropylene dispersers, specially designed to distribute water in an optimal way i.e., covering the entire airflow section. These dispersers will operate at low pressure (0.8 mCE), thus reducing pump power and producing large droplets that are little sensitive to vesicular entrainment.

Exchange surface

The Effi-Pack exchange surface will be made of thermoformed and welded PP sheets. Highly resistant to shocks and chemical agents and offering a maximized exchange surface, its free surface will be important. Resistant up to 75°C as standard, its excellent thermal efficiency will promote energy savings.

Drift eliminators

Highly efficient, they will strongly reduce water spraying out at the tower exit. Resistant to UV rays, they are easily removable from above to access the distributors and exchange surface if necessary. The drift will be 0.01% maximum of the recirculating water flow. They are certified by an independent body (EUROVENT).

Options

Water treatment can be integrated as an option, as well as Inductive Automatic Deconcentration installed in the room (see separate data sheet).

The different IB, ICV, ICVK soundproofing, or the EFFI-SILENT option will further optimize the sound level.