



**JACIR**

Cooling for life

**VAP**



## Induced draft polyester open cooling tower

### CONTENTS

Page(s)

Modular polyester cooling tower	2
Open circuit cooling tower principle	3
Manufacturing details – Options	4-8
Technical characteristics – VAP	9
Drawings and dimensions – VAP with basin	10
Drawings and dimensions – VAP without basin	11
Support	12-13
Choice of location	14
Water treatment	15
Prescription VAP	16-17
Prescription VAPX	18-19

Technical Documentation



# Modular polyester cooling tower VAP

## JACIR

With more than 60 years' experience, our company:

- ∞ Has invested in detailed research and development in order to propose technical solutions according to the environmental protection.
- ∞ Is today the European leader thanks to its technology beyond market requirements.

## STRONG POINTS OF POLYESTER COOLING TOWER: VAP series

- ∞ **DESIGN** Simple and robust with strong efficiency.
- ∞ **POLYESTER CONSTRUCTION** Self-supporting FRP casing, absolute corrosion resistance, SILVER-STEEL stainless steel sheet metal or optional X-STEEL grade (corrosion resistance greater than 316L).
- ∞ **TRANSMISSION** Direct coupling: without maintenance.
- ∞ **INFILL SUPPORT** X-STEEL stainless-steel.
- ∞ **EASY MAINTENANCE** Large access door on the whole height of the tower, sloped basin for a complete drain, no mechanical transmission
- ∞ **INFILL** Packing is made of high efficiency PP film and easy to clean.  
It has an excellent resistance to temperature (75°C in continuous) and till 95°C an option.
- ∞ **ELECTRICAL POWER** Induced draft axial fan with high performance.
- ∞ **INSTALLATION** Single part, single lift, with "plug and play" hydraulics and electrical connections.

## Open circuit cooling tower principle VAP series

A cooling tower is a heat exchanger which enables water to be cooled through direct contact with air. The heat transfer from water to air is carried out partly by sensible heat transfer, but mainly by latent heat transfer (evaporation of part of the water into the air), which makes it possible to reach cooling temperatures lower than ambient temperatures.

### Operation of a wet air cooler

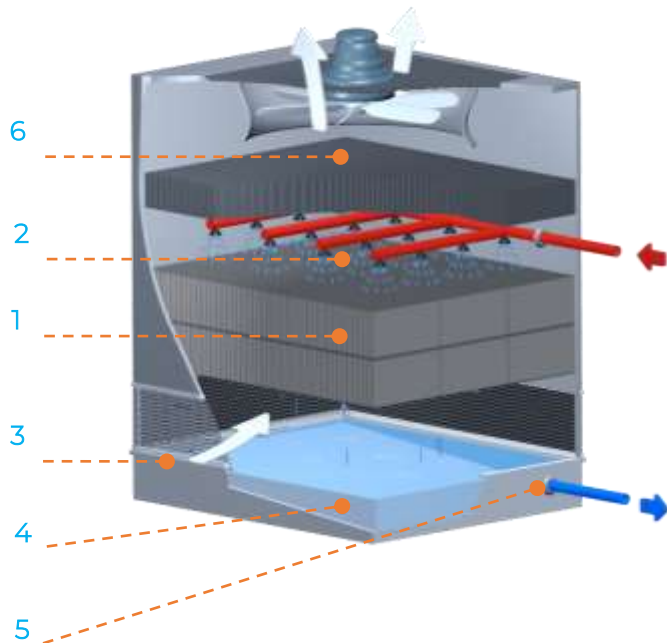

The hot water to be cooled is pumped to the top of the tower through pipes. This water is divided and distributed over the heat exchange surface (1) by water distribution nozzles (2).

Blown by the fan (3), the fresh air enters into the lower section of the unit and escapes through the upper section after being heated and saturated by passing through the wetted heat exchange surface.

As a result of surface tension, due to the exchange surface mesh, the water spreads in uniform way, falls down the whole height. The exchange surface is then increased.

The water, cooled thanks to the mechanical ventilation, falls into the inclined basin (4) under the tower. It then flows through the streamer (5). Drift eliminators (6) are installed at air outlet in order to limit the drift.

### Energy savings

- ∞ Chillers, condensers associated to a cooling tower will be cooled at a lower temperature and then will have a better cooling capacity. Their efficiency is higher.
- ∞ Seven to ten times more air must be blown in a dry cooler, which means a lot of fans and electric motors. So, the electrical consumption is about 40% higher.
- ∞ A tower cost is 30 to 50% that of a dry cooler for a same evacuated power.
- ∞ A 1°C increase of the ambient air has direct effect on dry air cooler's performance, while the efficiency of a cooling tower will not be as much affected as the wet bulb has not fluctuated in the same way.

# Manufacturing details VAP series

## Casing

The casing is made of self-supporting white Fiber Reinforced Polyester panels. All the steel parts for the assembly are moulded into the polyester.

The widespread use of plastics gives VAP exceptional corrosion resistance and significantly reduces maintenance costs. The lightness of plastics simplifies support structures and lifting operations. The aesthetically attractive design of the VAP makes it easy to integrate into the sophisticated architecture of a building, whether it is placed on the ground or on the roof.



## Accessibility

In standard, the VAP towers are delivered with a large access door, made in the same material as the casing: polyester. It is very light, and opens on the whole height of the tower, to all the internals. So the inspection, removal, and cleaning operations are very simple and easy.



## Sloped basin

The VAP can be delivered with or without polyester basin. It is made in one or two parts, assembled with external flanges to avoid bolting in contact with water.

The following connections are provided:

- ∞ Water outlet on the side or on the bottom,
- ∞ Spout overflow,
- ∞ Make up float valve,
- ∞ Complete drain flange, at the lowest part of the basin slope.



To secure the circuit cleanness, and no water stagnation, the complete drain of the basin is easy thanks to the slope and to the drain outlet, located at the lowest part of the basin. After drain, the bacteriological growth (Legionella) is impossible when the tower is stopped.

Concrete basin is possible: on the customer scope according to civil work guides lines and loads supplied by Jacir.



As an option, galvanized steel, Silver Steel casing or X-Steel stainless steel (for superior corrosion resistance compared to 316L) are also available: [VAPX series](#).

## Option VAPX

Delivered in two pre-assembled parts for the higher dimensions, it is equipped with a **POWER FLOW** (260x110mm) drain located at the lowest part of the inclined basin to enable the complete drain of the basin.



## Louvers

Fitted on stainless steel supports and made of polypropylene, sun ray proof louvers prevent both splash out and direct UV rays inside the basin.

Their double direction honeycomb shape prevents the entrance of particles in the air inlet. So, they help for a better control of bacteria growth.

The louvers are very fast and easy to be removed for complete access to the basin.



## Exchange surface: EFFI-PACK infill

The exchange surface made of thermoformed and welded polypropylene sheets is resistant to chocs and offers a large available surface lowering the fouling risks. The PP infill also offers the following benefits:

- ∞ High temperature resistance (75°C continuous),
- ∞ Highly efficient extended surface,
- ∞ Easy maintenance,
- ∞ High resistance to chemical agents,
- ∞ Range of operation up to 95°C on demand (option).

As an option, the infill Freefilm is also available: made of vacuum pressed PVC sheets, this material is non-putrescible, long lasting, also offers the following benefits:

- ∞ Very low pressure drop, so low power consumption thanks to the vertical channels,
- ∞ Highly resistant to fouling thanks to large size channels: 20mm for industry application,
- ∞ Can be used up to 58°C as standard. For higher temperatures involving specific designs: 80°C as option, PVC or ABS material,
- ∞ High thermal efficiency,
- ∞ Highly resistant to chemical agents,
- ∞ Suspended solids allowed: 80ppm,
- ∞ X-STEEL packing support as a standard,
- ∞ Fire classification M2, self-extinguishing.



## Water distribution

The water distribution is essential for optimized safe performance of the cooling tower.

Water enters a PEHD header, and then high-density Polyethylene pipes fitted with low pressure nozzles (8kPa). Their design secures even water splash on the whole section of the packing. These large diameter (12 to 32 mm) nozzles are highly resistant to clogging (even in the case of many suspended solids) and generate mainly large size drops. These drops being less sensitive to drift the bacteriological contamination risk is therefore reduced.

The pipes are connected to the header with efficient gaskets, and can be easily and entirely removed, without tools, saving maintenance costs and time while ensuring the sustainability of performance.



## Drift eliminators

Highly efficient, they prevent the water from being sprayed out of the tower and are easily removable and handy thanks to the handles designed for that purpose.

These drift eliminators are made of corrugated PVC blades, and have a certified efficiency of 0.01% minimum.

This efficiency has been certified by an independent external body (EUROVENT).



## Motor-fan unit

Mechanical equipment is installed on hot dip galvanized steel frame. It is arranged according to a vertical axis and includes: an aluminium axial fan with variable pitch at stand-still in standard, FRP as an option, and a low speed motor :

- ∞ Asynchronous motor,
- ∞ 500 to 750 rpm,
- ∞ IP 55 insulation, F class, special impregnation against moisture (tropicalization).

The fan is directly coupled to the motor shaft; this avoids the use of belts or gears, and reduces maintenance time and costs. Safety is secured by a stainless-steel grid at the top of the cooling tower.

### Delivery and erection

VAP cooling towers are factory assembled and delivered on site, ready to be connected. All the VAP cooling towers may be delivered with or without basin. Concerning locations installations with difficult access, VAP can also be delivered not assembled.

VAP cooling towers with FRP basin can be installed on a concrete surface or on a steel structure. Low weight of used materials allows a light supporting structure.

In case the cooling tower is delivered not assembled, the erection remains easy self-made on site.



### Connections



Once the cooling tower is erected, all piping must be connected: hot water inlet, make up water, cold water outlet and overflow are supported separately from the cooling tower. Water inlet and outlet connections flanges are in PP strengthened by fiberglass

Overflow is equipped by threshold overflow. Make up water is connected by thread tip. Electrical connections are made on the motor connection box.

## OPTIONS

- ∞ X-STEEL stainless steel casing (higher resistance to corrosion than 316L): [VAPX series](#),
- ∞ SILVER-STEEL casing: [VAPX series](#),
- ∞ Fan blades in polyester,
- ∞ High temperature infill (95°C),
- ∞ FREEFILM Packing (not EUROVENT certified),
- ∞ Basin and louvers,
- ∞ Grating walkway bellow the infill,
- ∞ Non-freezing heater with thermostat,
- ∞ Variable frequency drive,
- ∞ Counter flanges,
- ∞ High temperature resins for casing (80°C),
- ∞ Safety water switch (vibrating blade),
- ∞ Material delivered not factory pre-assembled,
- ∞ Erection on site by skilled technicians from our factory
- ∞ Access ladder to motor-fan unit (galvanized steel),
- ∞ Stainless steel (304,316) motor fan support



# Technical characteristics VAP



VAP (X) 24-24D MA	VAP (X) 24-24 MA	VAP (X) 29-24 MA	VAP (X) 30-30 MA	VAP (X) 35-30 MA	VAPX 35-35 MA	VAPX 40-40 MA	VAPX 45-45 MA
-------------------------	---------------------	---------------------	---------------------	---------------------	---------------------	---------------------	---------------------

Single speed motor									
Installed power (kW)	11	11	15	18,5	22	22	30	37	45
Speed (tr/min)	725	725	725	580	485	485	485	430	375
Absorbed power (kW)	6.2	10.3	13.8	16.8	19.4	19.1	23.9	24.4	30.6
Fan									
Diameter (mm)	1695	1695	1695	1990	2220	2415	2415	2725	3030
Sound level at 20 m (dBA)* Values± 2 dB(A)	67	67	67	68	68	68	69	70	71
Connections									
Water inlet (DN) / quantity	200 / 1	200 / 1	200 / 1	250 / 1	250 / 1	250/1	250/1	250/2	250/2
Water outlet (DN)** / quantity	200 / 1	200 / 1	225 / 1	225 / 1	225 / 1	250/1	250/1	250/2	250/2
Make up water on float valve (DN)	1"	1"	1"	1" ¼	1" ¼	1 ¼	1 ¼	1 ¼	1 ¼

\*: Free field at 1.5m of the ground

\*\* : Water outlet on the basin side, forced flow (if gravity outlet, diameter depends on the flow rate)

# Drawings and Dimensions VAP with basin

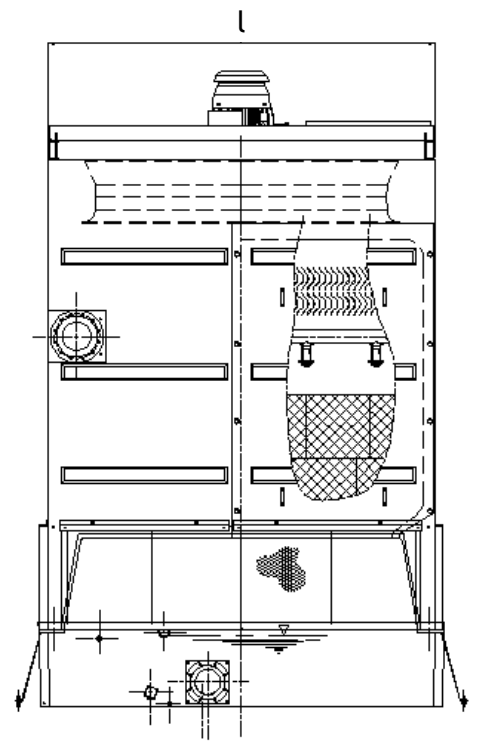
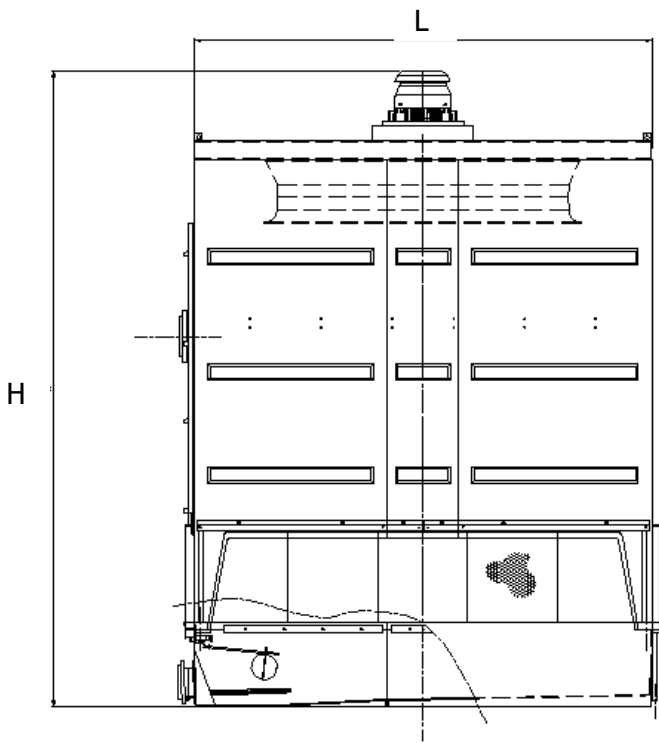

		VAP (X) 24-24D MA	VAP (X) 24-24 MA	VAP (X) 29- 24 MA	VAP (X) 30-30 MA	VAP (X) 35-30 MA	VAPX 35-35 MA	VAPX 40-40 MA	VAPX 45-45 MA	
L (mm)		2510	2510	3060	3150	3700	3740	3740	4255	4755
l (mm)		2510	2510	2510	3150	3150	3740	3740	4255	4755
H (mm)		4710	4710	4790	4940	4940	5080	5080	5900	5830
Shipping weight (kg)	Polyester	1300	1300	1550	2150	2360				
	Inox						3555	4055	5550	6600
Operating weight (kg)	Polyester	4280	4280	5345	7300	8380				
	Inox						9050	9550	12250	14400

## Drawings and Dimensions VAP without basin (concrete basin– customer supply)

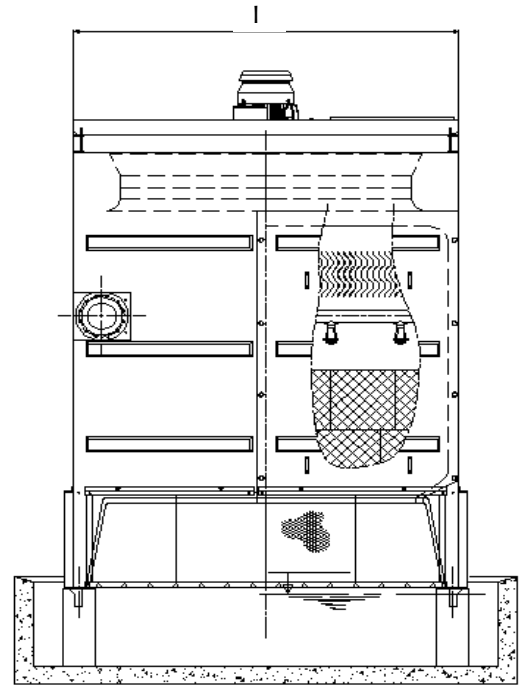
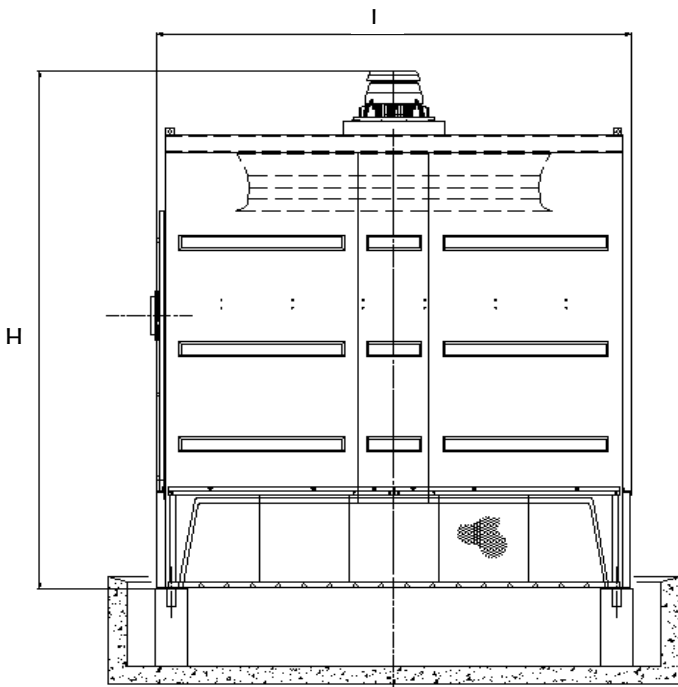

		VAP (X) 24-24D MA	VAP (X) 24-24 MA	VAP (X) 29- 24 MA	VAP (X) 30-30 MA	VAP (X) 35-30 MA	VAPX 35-35 MA	VAPX 40-40 MA	VAPX 45-45 MA	
L (mm)		2490	2490	3040	3130	3630	3770	3770	4230	4755
l (mm)		2490	2490	2490	3130	3130	3770	3770	4230	4755
H (mm)		4160	4160	4240	4340	4340	4480	4480	5120	5075
Shipping weight (kg)	Polyester	1150	1150	1350	1900	2050				
	Inox						3000	3500	4650	5500
Operating weight (kg)	Polyester	1560	1560	1855	2580	2850				
	Inox						3600	4100	6050	6900

# Support VAP

VAP cooling towers can stand on a concrete base or on steel frame beams (customer supply). Check that the ground can stand the operating load, and that surface or supports are flat and horizontal.

## Quantity and position of concrete or metallic beams (customer supply)

SUPPORT VAP 24-24 and VAP 24-24D

→ 4 BEAMS

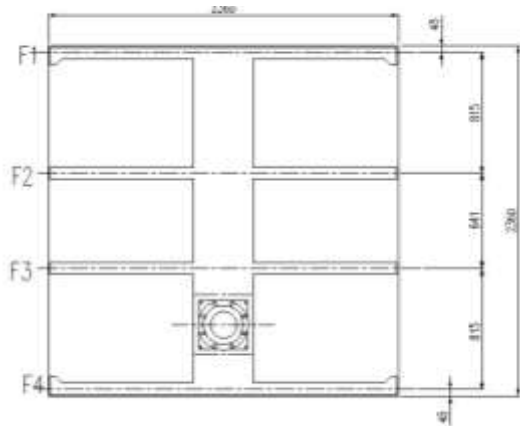

SUPPORT VAP 29-24

→ 4 BEAMS

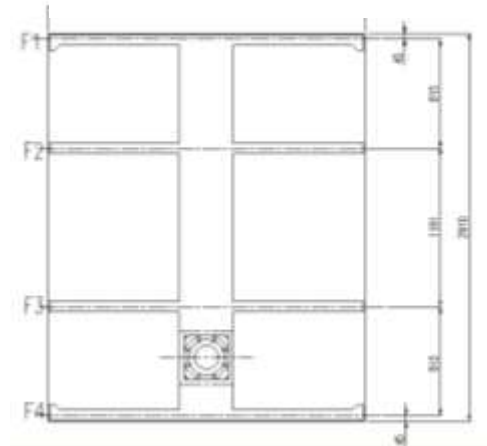

SUPPORT VAP 30-30

→ 5 BEAMS

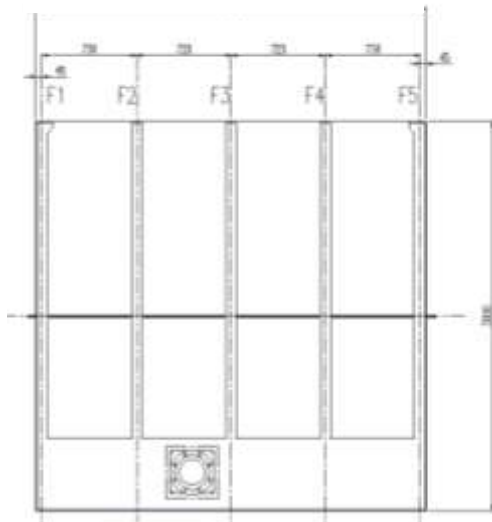

SUPPORT VAP 35-30

→ 5 BEAMS

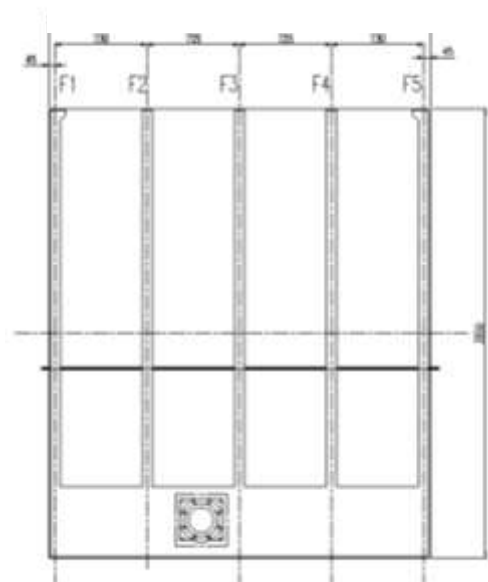

# Support VAP

SUPPORT VAP 35-35

→ 4 BEAMS (F)

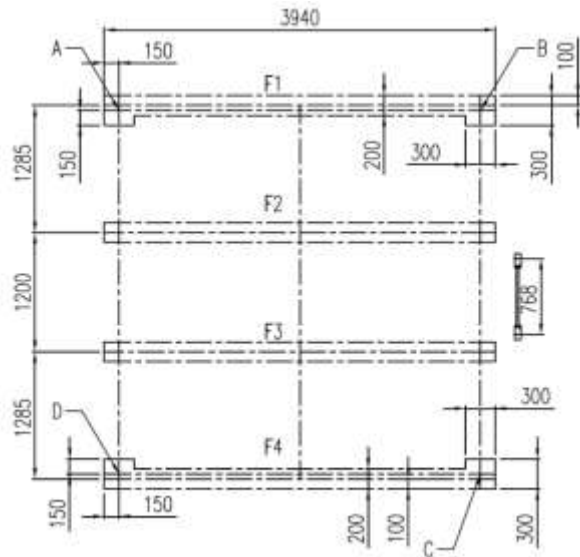

SUPPORT VAP 40-40

→ 9 BEAMS (F)

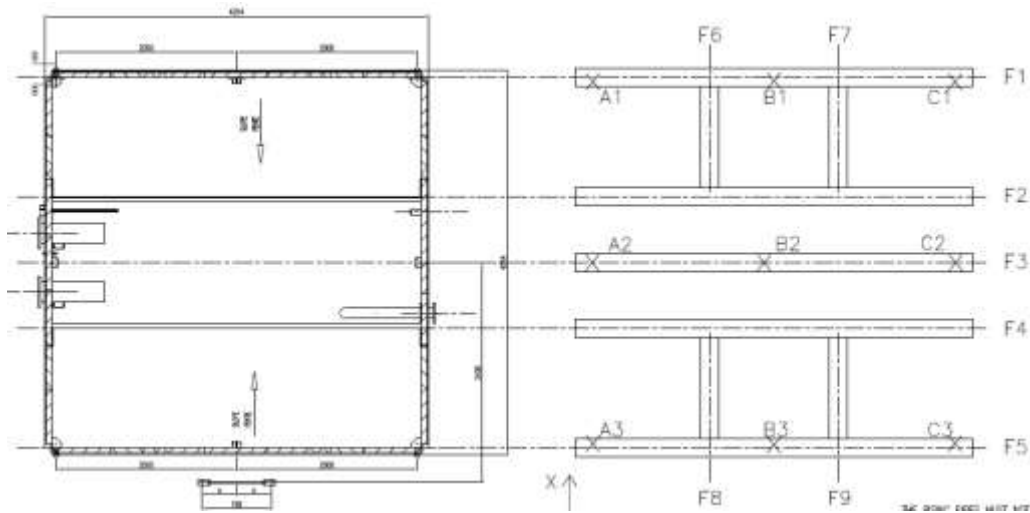

SUPPORT VAP 40-40

→ 7 BEAMS (F)

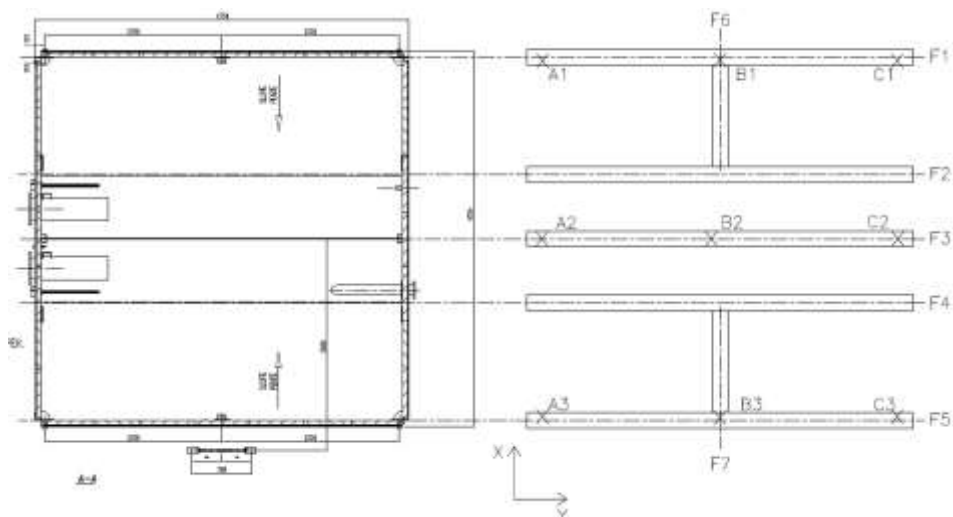

## Choice of location VAP series

Walls, higher or equal to the tower must not surround on all sides a cooling tower, furthermore without any openings. This could create a risk of a « re-circulation »; the air discharged (hot and saturated) may be recycled into the unit and significantly reduces the thermal efficiency of the tower.

In any case, the free access on the four sides of the tower must be secured to ensure that the fans are supplied correctly with air and that there is proper access for installation and maintenance.

If these rules are not applied, it is inevitable that the cooling tower will not operate properly.

### Recommended minimum free access (mm): Top view

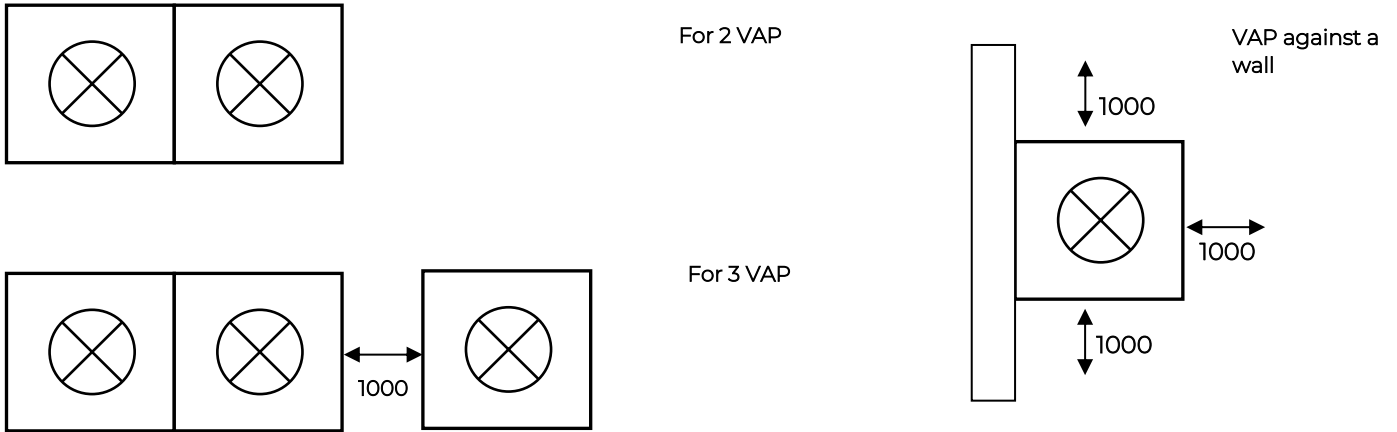

Do not hesitate to contact us for any advice

### Layout examples:

NO

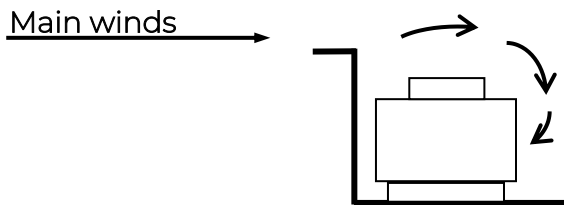

YES

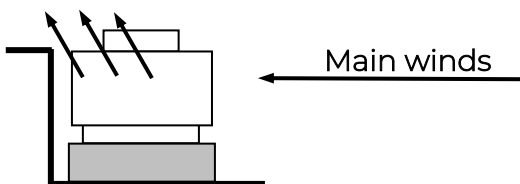

Positionner un socle pour élever le rejet d'air de la tour

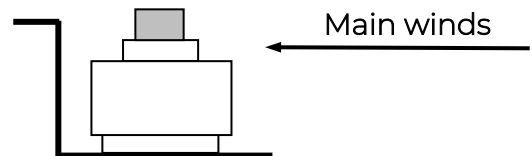

Positionner un cône de refoulement pour élever le rejet d'air de la tour

# Water treatment VAP

## WATER EVAPORATION

Consumption by evaporation is approximately kg/h 1,7 per kcal/h 1 000.

## DECONCENTRATION

Due to the evaporation and to the water recycling, impurities or salts in the water are concentrated. To make sure that this concentration is not too high, drain must be carried out. If not, concentration rates of 10, 100 or even 1,000 would occur over time.

In order to pre-determine the installation requirements, consider drain value twice the evaporation level. In operation, with an efficient water treatment, this figure may decrease, especially in the case of a stainless-steel cooling tower (concentration rate of 3 to 5 possible). There are three possible mitigation process according to the case:

### 1- Continuous blow down

Connection piece to be installed at the pump discharge just before the tower, if possible, at the level of the water distribution pipes so that the purge only takes place when the circulation pump is operating.

The blow down flow rate can be calculated using the formula:  $[100 S / (M - S)] \%$  of the make-up water in which:

S: Salinity of the make-up water compensating for evaporation.

M: Maximum acceptable salinity level of water in circuits.

### Example :

Salinity of make-up water = HT 20 ° F

Maximum acceptable salinity = HT 40 ° F

$100 \times 20 / (40 - 20) = 100 \%$  make-up water flow rate

Therefore, the continuous blow down must be equal to the evaporated make-up water flow rate (rate=2).

Consequently, the real water consumption is twice the theoretical evaporated water flow.

### 2- Discontinuous blow down

The conductivity of the water in the circuit is controlled and the device is purged while not exceeding the TH value.

### 3- JACIR Automated Inductive deconcentration device without maintenance

Once water conductivity level has been reached, a motorised valve can be activated to drain the required quantity of water to maintain the right concentration level.

(See separate documentation).

## WATER TREATMENT

It is essential that good quality water is available to ensure that the closed-circuit cooling network operates correctly.

If the water contains a significant amount of impurities, it is recommended that a filtration device to be installed in parallel for 5 to 10 % of the recycled water flow.

If the water contains salts that form deposits, iron or corrosive chemical elements, a make-up water treatment system must be installed to obtain purer water, which is close to being chemically neutral, and which can supply the cooling devices without causing damage.

In some cases, algae, moss, fungus or permanent shells can tend to grow in cooling towers. There are products that can be added periodically to the water circuit to stop these organisms from developing.

Water treatment should be undertaken by a specialized Company.

PREVENTS THE RISK OF LEGIONNAIRES' DISEASE: See separate documentation

# Prescription VAP

Evaporative induced draft polyester cooling tower, designed and manufactured by **Jacir, VAP**..... Thermal performance will be previously EUROVENT CTI certified and compliant to December 2020 NF E 38-324 standard.

## Thermal characteristics

The heat power will be ..... kW for conditions between .....°C to .....°C with a wet bulb of..... °C at air inlet.

## Tower casing and basin

The casing will be made of self-supporting white Fiber Reinforced Polyester panels. The metallic corner angles and all the steel parts for the assembly will be moulded into the polyester.

VAP will be equipped by a large access door in standard made in the same material as the casing; it will be very light, and will opens on the whole tower height, giving access to all the internals. So, inspections, removal, and cleaning will be very simple and easy.

On the basin will be installed an easy to adjust float valve, a complete drain flange at the lowest part of the basin slope, a spout overflow, a no-cavitation's strainer located on the side or on the bottom, and sun ray proof louvers. preventing both from splash out and from direct UV rays.

## Infill

The EFFI-PACK exchange surface will be made of thermoformed and welded Polypropylene sheets, will be resistant to chocks and will offer a large available surface. This system will ensure fouling risks reduction.

## Water distribution

Water will be distributed first by a header and then by distribution pipes, all in PEHD. These distribution pipes will be fitted with high efficiency polypropylene low pressure nozzles. The nozzles will distribute water on exchange surface in a uniform way and operate under very low pressure (8kPa) by a large water flow (diameter from 12 to 32 mm).

## Drift eliminators

Highly efficient, they will prevent the water from being sprayed out of the tower and will be easily removable and handy. These drift eliminators will be made of PVC waved blades, and will have an efficiency of 0.01% minimum of the flow when water is in recirculation.

This efficiency is certified by an independent external body (EUROVENT).

## Motor-fan unit

Mechanical equipment will be installed on hot dip galvanized steel frame which will take support on the whole cooler casing. It will be arranged according to a vertical axis and includes: an aluminium axial fan with variable pitch at stand-still and a low-speed motor:

- ∞ Asynchronous motor,
- ∞ 500 to 700 rpm,
- ∞ IP 55 insulation, F class, special impregnation against moisture (tropicalization).

The fan will be directly coupled to the motor shaft; avoiding the use of belts or gears.



## Connections

Once the cooling tower is erected, all piping will be connected: hot water inlet, make up water, cold water outlet and overflow, the whole supported separately from the cooling tower. Water inlet and outlet connections flanges will be in PP strengthened by fiberglass. Overflow will be equipped by threshold overflow. Electrical connections will be made on the motor connection box.

## Delivery and erection

VAP cooling towers will be factory assembled and delivered on site, ready to be connected. All the cooling towers may be delivered with or without basin. Concerning locations installations with difficult access, VAP may be delivered not assembled.

VAP cooling towers with basin may be installed on a concrete surface or on a steel structure. Low weight of materials will allow a light supporting structure. In case of cooling tower delivered not assembled, the erection will remain easy on site by the customer when bolting all elements together.

# Prescription VAPX

Evaporative induced draft polyester cooling tower, designed and manufactured by **Jacir, VAPX.....**

Thermal performance will be previously Eurovent CTI certified and compliant to December 2020 NF E 38-324 standard.

## Thermal characteristics

The heat power will be ..... kW for conditions between .....°C to .....°C with a wet bulb of..... °C at air inlet.

## Tower casing and basin

The cooling tower casing will be made of self-supporting steel panels, twice or 4 times folded on the 4 sides. Side panels will be designed to receive, if necessary, a double casing later on.

Stainless steel rivets with uniform and high-capacity locking will be used for assembly. The cooling tower casing will be assembled without any bolting or welding for the parts in contact with water; a special designed high covering seal ensure waterproofing between the panels.

On the basin will be installed a float valve easy to adjust, a complete drain flange (260x110 mm) at the lowest part of the basin slope (POWER FLOW), a spout overflow, a none cavitation's strainer located on the side or on the bottom, sun ray proof louvers preventing both from splash out and from direct UV rays.

## Casing structure

The cooling tower panels casing will be made of:

- ∞ galvanized steel 2 mm thick ZENDZIMIR process 275 gr/m<sup>2</sup> (galvanized plates are protected by the zinc oxidation on the surface) or,
- ∞ option SILVER-STEEL casing or,
- ∞ option X-STEEL stainless steel (corrosion resistance higher than 316L) for its long-lasting properties, water saving and easy cleaning.

## Infill

The EFFI-PACK exchange surface will be made of thermoformed and welded Polypropylene sheets, will be resistant to chocks and will offer a large available surface. This system will ensure fouling risks reduction.

## Water distribution

Water will be distributed first by a header and then by distribution pipes, all in PEHD. These distribution pipes will be fitted with high efficiency polypropylene low pressure nozzles. The nozzles will distribute water on exchange surface in a uniform way and operate under very low pressure (8kPa) by a large water flow (diameter from 12 to 32 mm).

## Drift eliminators

Highly efficient, they will prevent the water from being sprayed out of the tower and will be easily removable and handy. These drift eliminators will be made of PVC waved blades, and will have an efficiency of 0.01% minimum of the flow when water is in recirculation. This efficiency is certified by an independent external body (EUROVENT).

## Motor-fan unit

Mechanical equipment will be installed on hot dip galvanized steel frame which will take support on the whole cooler casing. It will be arranged according to a vertical axis and includes: an aluminium axial fan with variable pitch at stand-still and a low-speed motor:

- ∞ Asynchronous motor,
- ∞ 500 to 700 rpm,
- ∞ IP 55 insulation, F class, special impregnation against moisture (tropicalization).

The fan will be directly coupled to the motor shaft; avoiding the use of belts or gears.

## Connections

Once the cooling tower is erected, all piping will be connected: hot water inlet, make up water, cold water outlet and overflow, the whole supported separately from the cooling tower. Water inlet and outlet connections flanges will be in PP strengthened by fiberglass. Overflow will be equipped by threshold overflow. Electrical connections will be made on the motor connection box.

## Delivery and erection

VAP cooling towers will be factory assembled and delivered on site, ready to be connected. All the VAP cooling towers may be delivered with or without basin. Concerning locations installations with difficult access, VAP may be delivered not assembled.

VAP cooling towers with basin may be installed on a concrete surface or on a steel structure. Low weight of materials will allow a light supporting structure. In case the cooling tower will be delivered not assembled, the erection will remain easy on site by the customer when bolting all elements together.