

ERELIS 150 (ERE150)

GENERAL DATA



ULTRA-QUIET AND SLIM EXTRACTOR WITH BACK DRAUGHT DAMPER FOR CEILING AND WALL INSTALLATION.

MANUFACTURING FEATURES:

Ultra-quiet extractor for wall or ceiling installation with non-return damper to prevent the entry of unwanted or contaminating air. Eco-Friendly product manufactured with some recycled materials. Modern design with an ultra-thin 17mm thick front panel so that it does not come out when installed, which makes it a compact extractor ideal for short ducts (ideal for false ceilings and plasterboard). Very easy installation. Thanks to its impeller and motor anchor design with integrated deflectors we achieve very low sound levels with high airflows.

Housing and impeller made of UV-resistant ABS plastic (prevents aging caused by exposure to sunlight). Self-lubricated bushings motor protected against thermal overload. Maximum working temperature in continuous: 50°C.

IPX4 protection. IMQ Safety certificate to guaranty the electromechanical compatibility.

Options:

- Basic
- Timer (T)
- Humidity sensor (HR) and timer (T)
- Motion sensor (Motion)

APPLICATIONS:

Ideal for ventilation of small and medium spaces of domestic and commercial buildings. To be installed in ventilation ducts. Compatible with 100, 120 and 150 air ducts.

PERFORMANCE CURVE

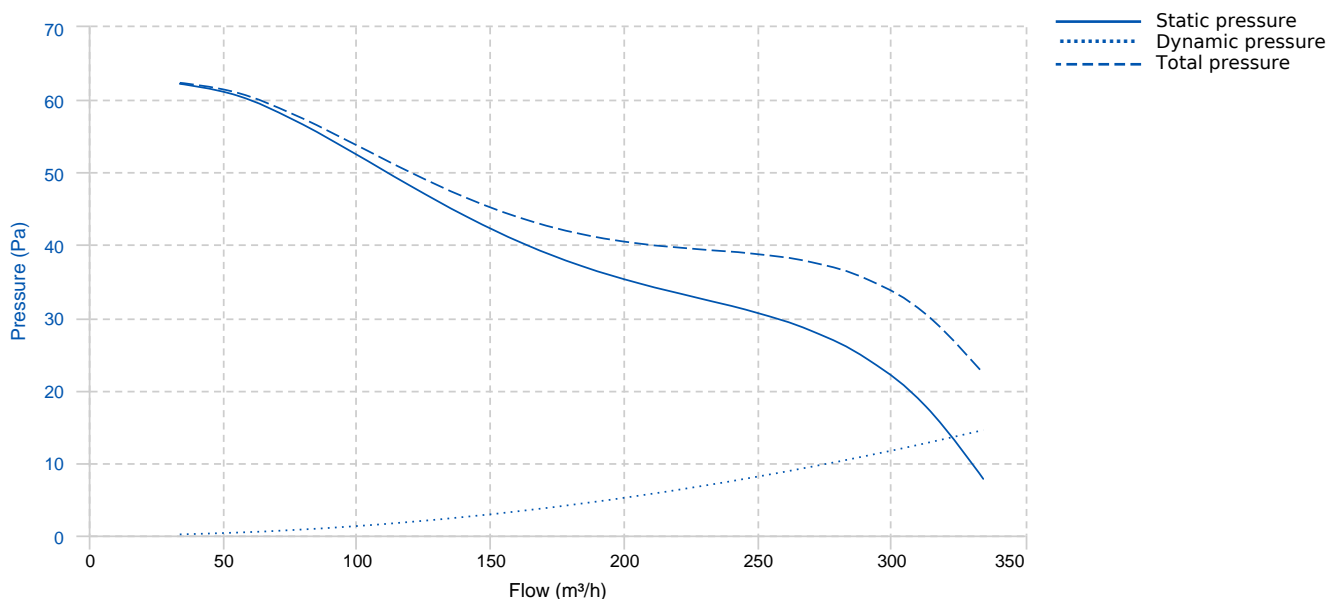

TECHNICAL DATA

Fan					
RPM	2100	Approx. weight	0.97 kg	Max. Flow	340 m ³ /h
Motor					
Power	2.800000000000000001E-2 kW	RPM	2100	I max. (230V)	0,15 A

DIMENSIONS

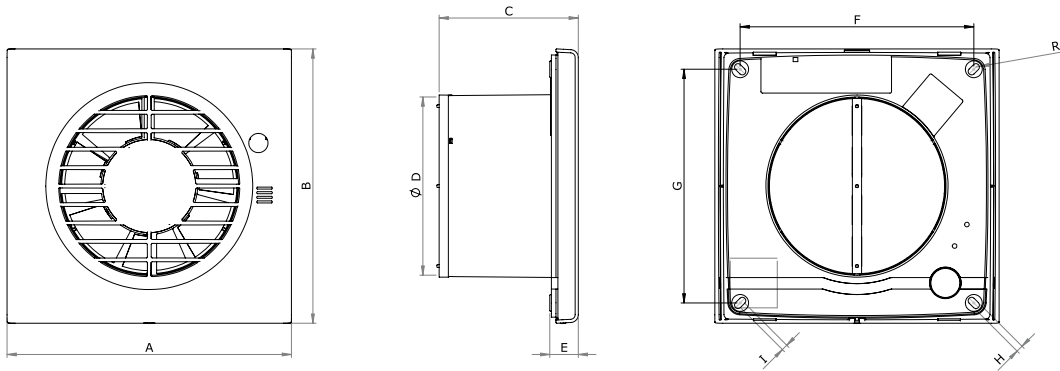

Dimensions (mm)									
A	218	B	213	C	98	D	155	E	18.5
F	185	G	185	H	4.5	I	4	R	2.3

WIRING DIAGRAM

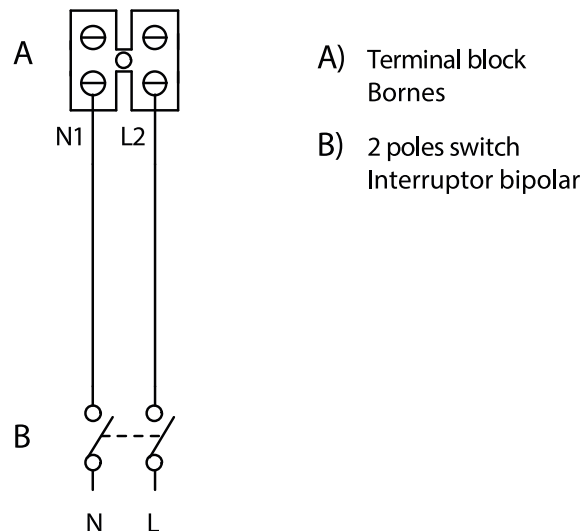



ACCESSORIES