

# BFSL and BFEL

High Pressure Fan Coil Unit

TECHNICAL LEAFLET

# BFSL

## High Pressure Fan Coil Unit with Asynchronous Motor

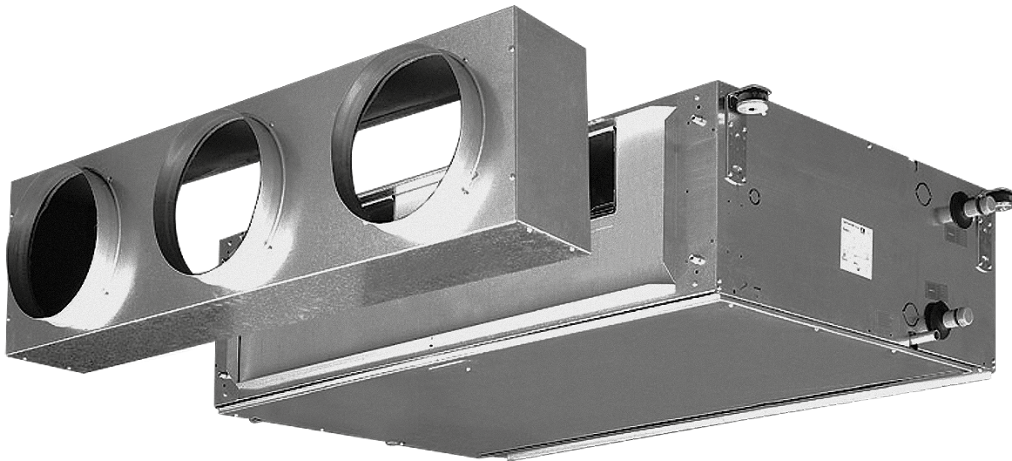

The **BFSL high pressure** fan coils are produced in 7 sizes.

Designed and built for concealed installations, they have small dimensions, are very silent and have a particularly interesting price in relation to their performance (elevated air flow rates and available static pressures up to 160 Pa for sizes 1-5 and 250 Pa for sizes 6-7).

They are suitable for climate control for small and medium commercial and sports environments or for large civil environments and integrate perfectly in regular false ceilings.

The sizes 1÷5 are equipped with **5 speed** fans, 3 of which are connected to the terminal board while the sizes 6-7 are equipped with **3 speed** fans.

The base models call for a 4 row coil but upon request, units with 3 row coils or additional coils (for 4 pipe systems) with one or two rows can be provided.

A complete set of accessories solves any type of system problem.

**Casing:** made of galvanized steel, 1 mm thick for sizes 1÷3 and 1,2 mm for sizes 4÷7, insulated with 10 mm polyolefin (PO) foam (B-s2-d0 EN 13501-1).

**Fan assembly:** consists of quiet centrifugal fans with two impellers (made of plastic for sizes 1÷5 and made of aluminium for sizes 6÷7) and a directly driven single phase motor (230 V - 50 Hz).

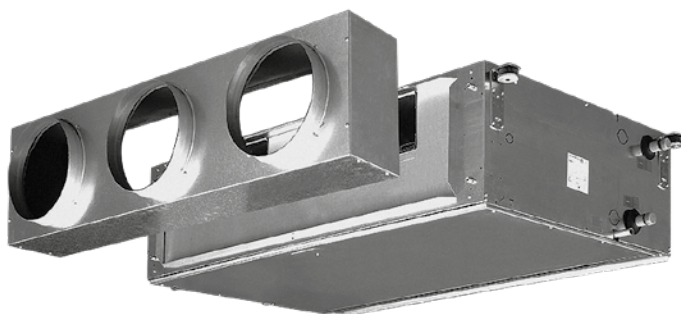

**Coil:** it is manufactured from drawn copper tube and the aluminium fins are mechanically bonded onto the tube by an expansion process.

The Trane range is available with the combination of either 3 or 4 row coils (sizes 1÷5) with the possibility to add a 1 or 2 row coil (3+1, 4+1, 3+2, 4+2 versions for 4 pipe systems), and 4 or 6 row coils (sizes 6-7) with the possibility to add a 2 row coil (4+2, 6+2 versions for 4 pipe systems).

**The connections are on the left hand side looking from the air inlet of the unit (see picture).**

**On request or on the construction site the connections can be moved to the other side.**

The coil is not suitable for use in corrosive atmosphere or in environments where aluminium may be subject to corrosion.

**Filter:** polypropylene cellular fabric regenerating filter.

The filter frame of galvanized steel is inserted into sliding guides fastened to the internal structure for easy insertion and removal of the filter.

**Condensate collection tray:** made from galvanized steel insulated with 3 mm polyolefin (PO) foam (B-s2-d0 EN 13501-1).

All range is compliant with the new **(EU) Regulation No. 327/2011** which requires **very low electric consumption ratings** in relation to performances provided.

## Left connections (standard)

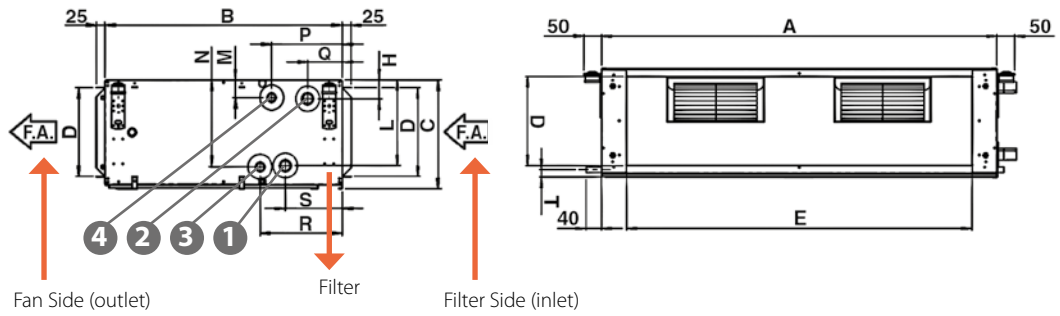

## Right connections (on request)

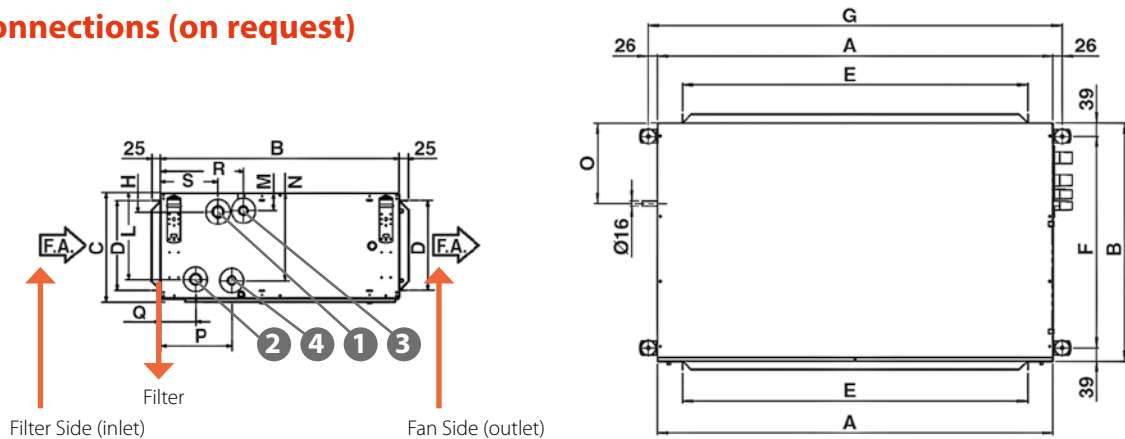

Model	Dimensions (mm)			
	O	P	Q	R
<b>BFSL 1÷5</b>	209	103	169	243
<b>BFSL 6-7</b>	304	154	264	338

Model	Dimensions											Coil			
	A	B	C	D	E	F	G	H	L	M	N	Main		Additional	
	mm	mm	mm	mm	mm	mm	mm	mm	mm	mm	mm	1	2	3	4
<b>BFSL 1</b>	1133	698	310	255	991	620	1185	54	245	50	249	3/4"	3/4"	3/4"	3/4"
<b>BFSL 2</b>	1133	698	310	255	991	620	1185	54	245	50	249	1"	1"	3/4"	3/4"
<b>BFSL 3</b>	1133	698	360	305	991	620	1185	54	295	50	299	1"	1"	3/4"	3/4"
<b>BFSL 4</b>	1445	853	360	293	1302	775	1497	58	291	54	295	1 1/4"	1 1/4"	1"	1"
<b>BFSL 5</b>	1445	853	435	368	1302	775	1497	58	367	54	370	1 1/4"	1 1/4"	1"	1"
<b>BFSL 6</b>	1535	1100	488	421	1393	1022	1587	59	416	55	421	1 1/4"	1 1/4"	1"	1"
<b>BFSL 7</b>	1535	1100	588	521	1393	1022	1587	59	516	55	521	1 1/4"	1 1/4"	1"	1"

Model	Weight without packaging (kg)						Weight with packaging (kg)						Water content (litres)			
	3R	3+1R	3+2R	4R	4+1R	4+2R	3R	3+1R	3+2R	4R	4+1R	4+2R	3R	4R	1R	2R
<b>BFSL 1</b>	45	48	50	47	50	51	48	51	53	50	53	54	2,0	2,6	0,9	1,5
<b>BFSL 2</b>	46	50	52	48	51	53	49	53	55	51	54	56	2,9	3,7	1,1	1,8
<b>BFSL 3</b>	54	58	60	56	60	62	57	61	63	59	63	65	3,5	4,6	1,4	2,4
<b>BFSL 4</b>	75	80	83	78	83	86	79	84	87	82	87	90	4,7	6,0	2,0	3,2
<b>BFSL 5</b>	85	90	94	88	94	98	89	94	98	92	98	102	5,7	7,1	2,7	4,1

	4R	4+2R	6R	6+2R	4R	4+2R	6R	6+2R	4R	6R	2R
<b>BFSL 6</b>	124	134	130	140	127	137	133	143	7,6	11,1	4,1
<b>BFSL 7</b>	140	152	148	160	143	155	151	163	9,7	13,8	5,5

## Units with 4 row coil

**2 pipe units.** The following standard rating conditions are used:

**COOLING (summer mode)**

**Entering air temperature:** +27 °C d.b. +19 °C w.b.  
**Water temperature:** +7 °C E.W.T. +12 °C L.W.T.

**HEATING (winter mode)**

**Entering air temperature:** +20 °C  
**Water temperature:** +45 °C E.W.T. +40 °C L.W.T.

Model BFSL		BFSL 14			BFSL 24			BFSL 34			BFSL 44			BFSL 54 (**)			BFSL 64 (**)			BFSL 74 (**)				
		1	3	5	1	3	5	1	3	5	1	3	5	1	3	5	1	3	5	1	3	5		
Speed																								
Air flow (E)	m <sup>3</sup> /h	790	1125	1410	840	1410	1825	1710	2075	2440	2070	2580	3020	2740	3280	3850	1880	3385	4800	3925	5070	7100		
Available pressure (E)	Pa	25	50	75	15	50	80	30	50	70	35	50	70	35	50	70	150	150	150	150	150	150		
Cooling total emission (E)	kW	4,17	5,21	5,92	4,99	7,01	8,15	8,71	9,76	10,71	10,90	12,40	13,60	14,54	16,19	17,76	12,42	18,73	22,89	21,54	25,33	30,63		
Cooling sensible emission (E)	kW	3,25	4,26	5,03	3,66	5,48	6,62	6,67	7,68	8,65	8,25	9,70	10,90	11,21	12,80	14,37	8,88	14,16	17,98	16,05	19,46	24,53		
Heating (E)	kW	4,98	6,44	7,67	5,57	8,27	10,10	10,20	11,75	13,19	12,79	14,92	16,53	17,67	20,32	22,93	20,86	33,52	43,60	39,34	47,85	61,14		
Dp Cooling (E)	kPa	5,1	7,6	9,6	6,9	12,7	16,8	16,0	19,8	23,4	13,9	17,7	20,9	13,3	16,3	19,4	7,4	15,3	22,6	14,4	19,3	27,6		
Dp Heating (E)	kPa	5,2	8,2	11,3	6,2	17,0	18,3	15,6	23,0	24,8	13,4	17,7	21,3	14,2	18,3	22,8	3,9	9,1	14,7	8,5	12,1	18,8		
Fan (E)	W	115	154	191	170	230	285	350	420	470	390	490	570	500	617	760	574	778	1304	1518	1758	2460		
Sound power outlet (E)	dB(A)	44	52	58	44	56	61	57	62	65	59	63	66	63	67	70	63	71	77	71	75	81		
Sound power inlet + radiated (E)	dB(A)	47	55	60	47	59	64	60	64	67	61	65	68	65	69	72	-	-	-	-	-	-		
Sound pressure outlet (*)	dB(A)	35	43	49	35	47	52	48	53	56	50	54	57	54	58	61	54	62	68	62	66	72		
Sound pressure inlet + radiated (*)	dB(A)	38	46	51	38	50	55	51	55	58	52	56	59	56	60	63	-	-	-	-	-	-		
Plenum code		9034200			9034200			9034220			9034230			9034240			9034280			9034290				

## Units with additional coil

**4 pipe units.** The following standard rating conditions are used:

**COOLING (summer mode)**

**Entering air temperature:** +27 °C d.b. +19 °C w.b.  
**Water temperature:** +7 °C E.W.T. +12 °C L.W.T.

**HEATING (winter mode)**

**Entering air temperature:** +20 °C  
**Water temperature:** +65 °C E.W.T. +55 °C L.W.T.

Model BFSL		BFSL 14+1			BFSL 24+1			BFSL 34+1			BFSL 44+1			BFSL 54+1 (**)			BFSL 64+2 (**)			BFSL 74+2 (**)				
		1	3	5	1	3	5	1	3	5	1	3	5	1	3	5	1	3	5	1	3	5		
Speed																								
Air flow (E)	m <sup>3</sup> /h	770	1090	1350	840	1390	1775	1680	2045	2390	2055	2545	2960	2700	3245	3800	1860	3330	4680	3920	5040	6980		
Available pressure (E)	Pa	25	50	75	15	50	80	30	50	70	35	50	70	35	50	70	150	150	150	150	150	150		
Cooling total emission (E)	kW	4,09	5,11	5,79	4,99	6,96	8,03	8,61	9,67	10,58	10,85	12,34	13,46	13,75	15,31	16,73	12,33	18,56	22,52	21,53	25,25	30,36		
Cooling sensible emission (E)	kW	3,18	4,16	4,87	3,66	5,42	6,49	6,58	7,60	8,51	8,21	9,61	10,72	10,62	12,13	13,56	8,81	14,02	17,62	16,05	19,39	24,28		
Heating (E)	kW	3,96	4,87	5,47	4,63	6,28	7,16	7,62	8,47	9,20	9,83	11,07	12,00	12,67	14,00	15,28	19,81	29,78	37,13	35,50	41,88	51,31		
Dp Cooling (E)	kPa	4,90	7,30	9,20	6,90	12,50	16,30	15,70	19,40	22,90	13,80	17,40	20,50	12,00	14,70	17,40	7,30	15,00	22,00	14,40	19,10	27,10		
Dp Heating (E)	kPa	11,7	17,0	21,0	14,5	25,2	31,9	15,9	19,3	22,3	27,6	34,1	39,5	26,0	31,1	36,3	11,9	24,9	37,0	23,8	32,0	46,1		
Fan (E)	W	115	154	191	170	230	285	350	420	470	390	490	570	500	617	760	565	750	1327	1499	1727	2376		
Sound power outlet (E)	dB(A)	44	52	58	44	56	61	57	62	65	59	63	66	63	67	70	63	71	77	71	75	81		
Sound power inlet + radiated (E)	dB(A)	47	55	60	47	59	64	60	64	67	61	65	68	65	72	72	-	-	-	-	-	-		
Sound pressure outlet (*)	dB(A)	35	43	49	35	47	52	48	53	56	50	54	57	54	58	61	54	62	68	62	66	72		
Sound pressure inlet + radiated (*)	dB(A)	38	46	51	38	50	55	51	55	58	52	56	59	56	60	63	-	-	-	-	-	-		
Plenum code		9034200			9034200			9034220			9034230			9034240			9034280			9034290				

(E) = EUROVENT certified performance.

(\*) = The sound pressure levels are 9 dB(A) lower than the sound power levels and apply to the reverberant field of a 100 m<sup>3</sup> room and a reverberation time of 0.5 sec.

(\*\*) = Models not covered by EUROVENT certification program.

**Kit 230 V**     **Main and auxiliary coil valve kit**  
 (to be used only with ON/OFF 230 V controls:  
 QCV-MB2, T-TMO and T-REM)

230 V, ON-OFF valve.



**Kit 24 V**     **Main and auxiliary coil valve kit**  
 (to be used only with QCV-MB2 modulating valve  
 control board)

Valve with 3 points - 24 Volt actuator.



**BCM**     **External auxiliary condensate collection tray**

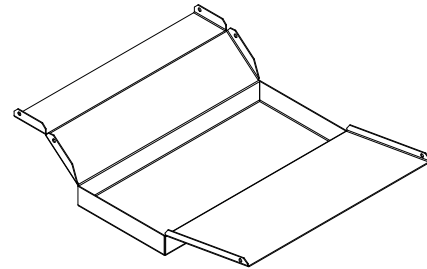

**BEM**     **Electric coil**

Consists of electric resistances and a security thermostat, which are inside a galvanized steel and insulated casing.

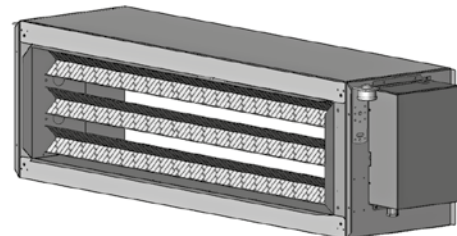

**PMM**     **Intake/supply spigot plenum**

Intake/supply spigot plenum with 3 spigots (Sizes 1 - 2 - 3) or 4 spigots (Sizes 4 - 5).

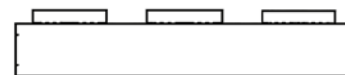

**SFM**     **ePM<sub>10</sub> 50% - G4 class synthetic filter**

The filter is a washable synthetic fibre, flame-proof according to Class F1 DIN 53438.  
 Compliant with: EN 16890.

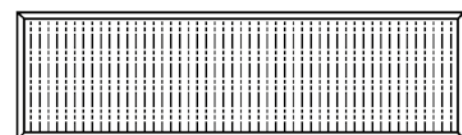

**SFM-F6**      **ePM<sub>10</sub> 70% - F6 class Synthetic Filter**  
(for sizes 6 ÷ 7 only)  
High efficiency compact filter in glass microfiber paper. Compliant with: EN 16890.

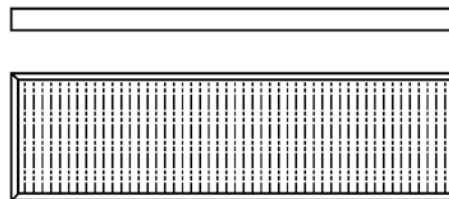

**GAV**      **Antivibrating connection**  
Intake/supply antivibrating connection, made of two galvanized frames and a PVC flexible connection.



### Electronic wall controls

<b>COM</b>	Speed selector with 4 positions: OFF, first speed, second speed, third speed
<b>M-3V</b>	3 speed control
<b>T-TMO</b>	3 speed control with electronic thermostat and manual summer/winter switch
<b>T-REM</b>	3 speed control with electronic thermostat and centralized/manual summer/winter switch
<b>T-AUTO</b>	Automatic speed control with electronic thermostat and summer/winter switch (to be used with T-POWER-M01 and T-POWER-A01 only)
<b>IR-MB2S</b>	IR-MB2S wall control (to be used with T-POWER-M01 and T-POWER-A01 only)
<b>REL-1</b>	Receiving board for centralized control
<b>T-POWER-M01</b>	T-POWER-A01 power unit for T-AUTO and IR-MB2S remote controls, fitted on the unit
<b>T-POWER-A01</b>	T-POWER-A01 power unit for T-AUTO and IR-MB2S remote controls, not fitted on the unit

### Electronic controls for MB boards

<b>QCV-MB2</b>	MB control panel version (IR-MB2S wall control included)
<b>TODS</b>	TODS multifunction control panel (to be used with QCV-MB2 control panel only)

#### Management system for a network of fan coils

<b>ROUTER-A</b>	Router for BMS systems not provided by Trane
<b>ROB-A</b>	Relay output board

# BFEL

## High Pressure Fan Coil Unit with EC Brushless Electronic Motor and Inverter Board

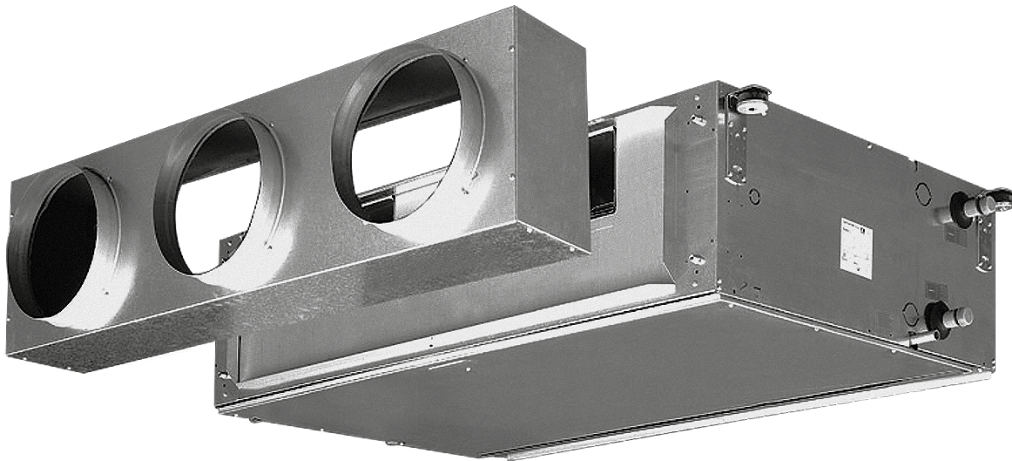

The **BFEL high pressure** fan coils are produced in 6 sizes.

Designed and built for concealed installations, they have small dimensions, are very silent and have a particularly interesting price in relation to their performance (elevated air flow rates and available static pressures up to 240 Pa).

They are suitable for climate control for small and medium commercial and sports environments or for large civil environments and integrate perfectly in regular false ceilings.

In high pressure ducted fan coils, the ability to **continuously** vary the air flow gives great regulation and control flexibility, at the same time **ensuring** excellent environmental conditions and extremely low electrical consumption.

**The ECM range** makes use of the excellent experience gained with the Cassette fan coils with inverter board, first in the world in production since 2009, and which have had great success on all markets.

The innovative synchronous electronic motor with permanent magnets, is controlled by an electronic board (inverter).



The air flow rate can be varied **in continuously** by means of a 1-10 V signal generated by Trane controls or by independent control systems.

The continuous air flow control improves the acoustic comfort and allows a more punctual reply to the variation of the thermal loads and a greater stability of the requested ambient temperature.

The extreme efficiency, also at low speed, makes possible a great reduction in electric consumption (in comparison to the yet efficient BFSL motor) un-

der normal operating conditions. The excellent values of the BFEL range have been maintained **in all working conditions**, without any resonance phenomenon at any frequency.

**The full compliance with the Electromagnetic Compatibility Directive** and with the other severe Standards in force is certified by an independent institute.

For the technical characteristics of the various components refer to High Pressure Fan Coil BFSL unit, except for **Electronic motor**: three phase permanent magnet electronic one that is controlled with current reconstructed according to a **BLAC** sinusoidal wave.

The inverter board that controls the motor operation is powered by 230 Volt, single-phase and, with a **switching system**, it generates a three-phase frequency modulated, wave form power supply. The electric power supply required for the machine is therefore single-phase with voltage of **230 V** and frequency of **50 - 60 Hz**.

All range is compliant with the new **(EU) Regulation No. 327/2011** which requires very low electric consumption ratings in relation to performances provided.

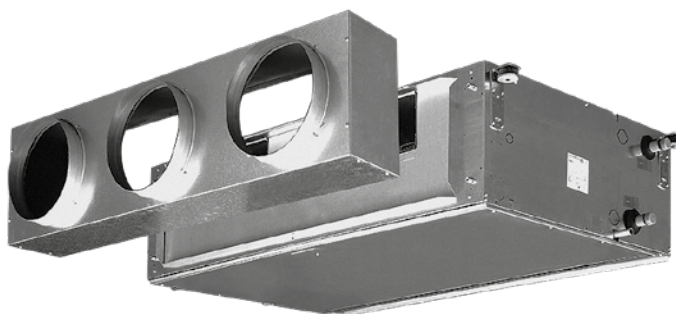

**Left connections (standard)**

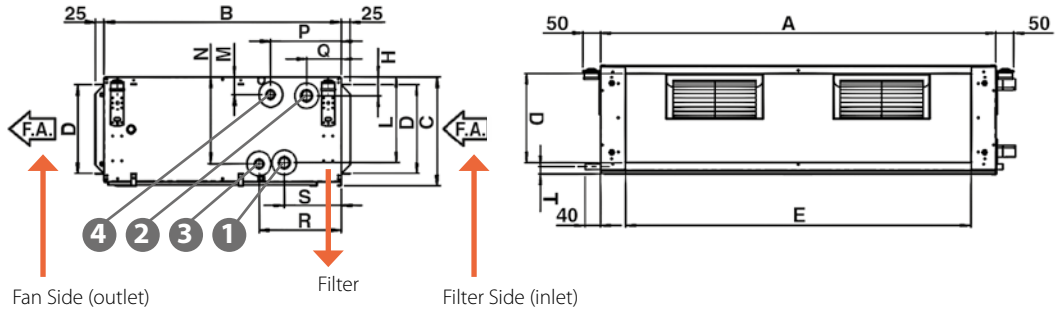

**Right connections (on request)**

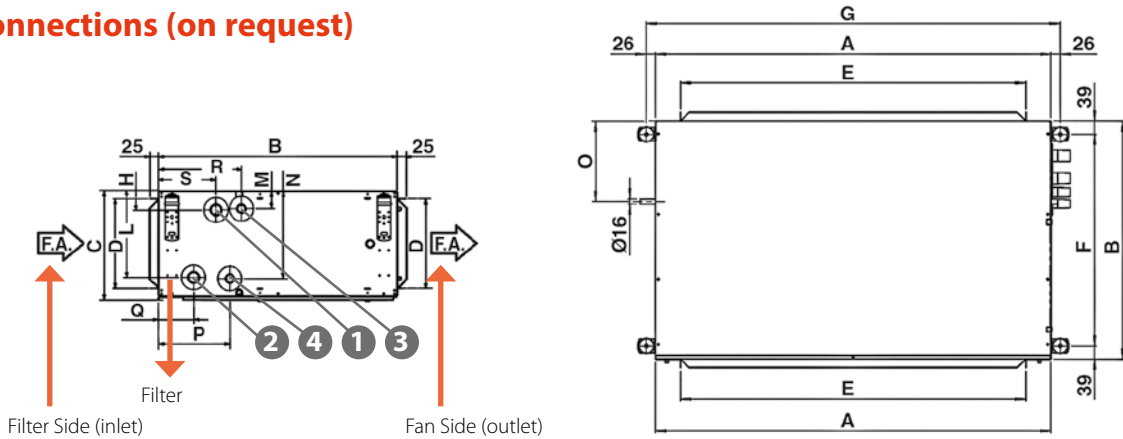

Model	Dimensions (mm)			
	O	P	Q	R
<b>BFEL 1+6</b>	209	103	169	243

Model	Dimensions											Coil			
	A	B	C	D	E	F	G	H	L	M	N	Main		Additional	
	mm	mm	mm	mm	mm	mm	mm	mm	mm	mm	mm	1 IN	2 OUT	3 IN	4 OUT
<b>BFEL 1</b>	1133	698	310	255	991	620	1185	54	245	50	249	3/4"	3/4"	3/4"	3/4"
<b>BFEL 2</b>	1133	698	310	255	991	620	1185	54	245	50	249	1"	1"	3/4"	3/4"
<b>BFEL 3</b>	1133	698	360	305	991	620	1185	54	295	50	299	1"	1"	3/4"	3/4"
<b>BFEL 4</b>	1445	853	360	293	1302	775	1497	58	291	54	295	1 1/4"	1 1/4"	1"	1"
<b>BFEL 5</b>	1445	853	435	368	1302	775	1497	58	367	54	370	1 1/4"	1 1/4"	1"	1"
<b>BFEL 6</b>	1535	1100	488	421	1393	1022	1587	59	416	55	421	1 1/4"	1 1/4"	1"	1"

Model	Weight without packaging (kg)						Weight with packaging (kg)						Water content (litres)								
	3R	3+1R	3+2R	4R	4+1R	4+2R	6R	6+2R	3R	3+1R	3+2R	4R	4+1R	4+2R	6R	6+2R	3R	4R	6R	1R	2R
<b>BFEL 1</b>	45	48	50	47	50	51	-	-	48	51	53	50	53	54	-	-	2,0	2,6	-	0,9	1,5
<b>BFEL 2</b>	46	50	52	48	51	53	-	-	49	53	55	51	54	56	-	-	2,9	3,7	-	1,1	1,8
<b>BFEL 3</b>	54	58	60	56	60	62	-	-	57	61	63	59	63	65	-	-	3,5	4,6	-	1,4	2,4
<b>BFEL 4</b>	75	80	83	78	83	86	-	-	79	84	87	82	87	90	-	-	4,7	6,0	-	2,0	3,2
<b>BFEL 5</b>	85	90	94	88	94	98	-	-	89	94	98	92	98	102	-	-	5,7	7,1	-	2,7	4,1
<b>BFEL 6</b>	-	-	-	124	-	134	130	140	-	-	-	127	-	137	133	143	-	7,6	11,1	-	4,1

## Units with 4 row coil

**2 pipe units.** The following standard rating conditions are used:

**COOLING (summer mode)**

**Entering air temperature:** +27 °C d.b. +19 °C w.b.  
**Water temperature:** +7 °C E.W.T. +12 °C L.W.T.

**HEATING (winter mode)**

**Entering air temperature:** +20 °C  
**Water temperature:** +45 °C E.W.T. +40 °C L.W.T.

Model BFEL	BFEL 14			BFEL 24			BFEL 34			BFEL 44			BFEL 54			
	MIN	MED	MAX	MIN	MED	MAX	MIN	MED	MAX	MIN	MED	MAX	MIN	MED	MAX	
<b>Inverter Power</b>	4,5	7	9	4	6	8	4,5	6,5	8	5,5	7,5	10	3	5	7	
<b>Speed</b>																
Air flow (E)	m <sup>3</sup> /h	780	1100	1310	940	1360	1780	1380	1950	2390	1840	2440	3080	2400	3320	3920
Available pressure (E)	Pa	26	50	70	24	50	85	25	50	75	28	50	80	25	50	70
Cooling total emission (E)	kW	4,14	5,11	5,61	5,44	6,86	7,94	7,87	9,70	10,81	10,47	12,39	13,99	13,73	16,70	18,17
Cooling sensible emission (E)	kW	3,24	4,18	4,72	4,08	5,36	6,44	5,93	7,61	8,72	7,90	9,65	11,23	10,46	13,26	14,75
Heating (E)	kW	5,18	6,80	7,76	6,42	8,64	10,62	8,64	11,25	13,06	12,13	15,15	18,08	15,90	20,51	23,25
Dp Cooling (E)	kPa	4,9	7,2	8,7	7,7	11,8	15,8	11,7	17,4	21,6	12,2	16,9	21,7	12,3	17,9	21,4
Dp Heating (E)	kPa	6,5	10,7	13,7	7,5	12,9	18,8	10,1	16,4	21,4	11,6	17,4	23,9	12,8	20,3	25,4
Fan (E)	W	40	88	144	44	110	225	80	195	340	110	253	530	166	383	702
Sound power outlet (E)	dB(A)	45	52	59	45	55	61	52	60	64	55	62	67	58	67	71
Sound power inlet + radiated (E)	dB(A)	48	55	61	48	57	63	55	62	66	58	64	69	61	70	73
Sound pressure outlet (*)	dB(A)	36	43	50	36	46	52	43	51	55	46	53	58	49	58	62
Sound pressure inlet + radiated (*)	dB(A)	39	46	52	39	48	54	46	53	57	49	55	60	52	61	64
Plenum code		9034200			9034200			9034220			9034230			9034240		

Model BFEL	BFEL 64			BFEL 66			
	MIN	MED	MAX	MIN	MED	MAX	
<b>Inverter Power</b>	3	6	9	3	6	9	
<b>Speed</b>							
Air flow (E)	m <sup>3</sup> /h	2825	4295	5205	2825	4295	5205
Available pressure (E)	Pa	22	50	74	22	50	74
Cooling total emission (E)	kW	16,91	21,91	24,3	20,36	27,2	30,64
Cooling sensible emission (E)	kW	12,85	17,79	20,3	14,47	20,39	23,48
Heating (E)	kW	18,63	25,83	29,76	20,74	29,57	34,54
Dp Cooling (E)	kPa	15,9	25,9	31,8	21,3	36,6	46,1
Dp Heating (E)	kPa	14,2	25,6	33,1	16,7	31,7	42
Fan (E)	W	106	330	636	109	339	654
Sound power outlet (E)	dB(A)	57	69	73	57	69	73
Sound power inlet + radiated (E)	dB(A)	60	71,5	75	60	71,5	75
Sound pressure outlet (*)	dB(A)	48	60	64	48	60	64
Sound pressure inlet + radiated (*)	dB(A)	51	63	66	51	63	66
Plenum code		9034280			9034280		

(E) = EUROVENT certified performance.

(\*) = The sound pressure levels are 9 dB(A) lower than the sound power levels and apply to the reverberant field of a 100 m<sup>3</sup> room and a reverberation time of 0.5 sec.

BFEL

## Units with additional coil

**2 pipe units.** The following standard rating conditions are used:

### COOLING (summer mode)

**Entering air temperature:** +27 °C d.b. +19°C w.b.  
**Water temperature:** +7 °C E.W.T. +12°C L.W.T.

### HEATING (winter mode)

**Entering air temperature:** +20 °C  
**Water temperature:** +65 °C E.W.T. +55 °C L.W.T.

Model BFEL	BFEL 14+1			BFEL 24+1			BFEL 34+1			BFEL 44+1			BFEL 54+1		
	MIN	MED	MAX	MIN	MED	MAX	MIN	MED	MAX	MIN	MED	MAX	MIN	MED	MAX
<b>Inverter Power</b>	4,5	7	9	4	6	8	4,5	6,5	8	5,5	7,5	10	3	5	7
<b>Speed</b>															
Air flow (E) m <sup>3</sup> /h	750	1040	1250	920	1340	1750	1350	1920	2350	1810	2400	3040	2380	3300	3860
Available pressure (E) Pa	26	50	72	24	50	85	25	50	75	28	50	80	26	50	68
Cooling total emission (E) kW	4,04	4,94	5,46	5,36	6,79	7,87	7,76	9,59	10,70	10,36	12,27	13,90	13,66	16,62	18,00
Cooling sensible emission (E) kW	3,14	4,01	4,55	4,01	5,30	6,35	5,83	7,51	8,61	7,79	9,53	11,13	10,39	13,19	14,58
Heating (E) kW	3,43	4,18	4,62	4,33	5,42	6,25	5,90	7,20	8,02	8,06	9,48	10,75	10,53	12,67	13,77
Dp Cooling (E) kPa	4,6	6,8	8,3	7,5	11,6	15,5	11,4	17,1	21,2	12,0	16,6	21,4	11,2	16,3	19,4
Dp Heating (E) kPa	9,4	13,4	16,0	13,6	20,4	26,4	9,9	14,3	17,3	19,6	26,3	33,0	18,5	25,7	29,9
Fan (E) W	40	88	144	44	115	225	80	200	340	110	253	530	168	384	695
Sound power outlet (E) dB(A)	45	52	59	45	55	61	52	60	64	55	62	67	58	67	71
Sound power inlet + radiated (E) dB(A)	48	55	61	48	57	63	55	62	66	58	64	69	61	70	73
Sound pressure outlet (*) dB(A)	36	43	50	36	46	52	43	51	55	46	53	58	49	58	62
Sound pressure inlet + radiated (*) dB(A)	39	46	52	39	48	54	46	53	57	49	55	60	52	61	64
Plenum code	9034200			9034200			9034220			9034230			9034240		

Model BFEL	BFEL 64+2			BFEL 66+2		
	MIN	MED	MAX	MIN	MED	MAX
<b>Inverter Power</b>	3	6	9	3	6	9
<b>Speed</b>						
Air flow (E) m <sup>3</sup> /h	2790	4235	5140	2750	4190	5090
Available pressure (E) Pa	21	50	73	22	50	74
Cooling total emission (E) kW	16,77	21,71	24,1	20,08	26,91	30,34
Cooling sensible emission (E) kW	12,72	17,59	20,09	14,26	20,13	23,2
Heating (E) kW	23,2	30,58	34,54	22,98	30,38	34,35
Dp Cooling (E) kPa	15,7	25,4	31,4	20,8	35,9	45,4
Dp Heating (E) kPa	20,1	33,2	41,3	19,8	32,8	40,8
Fan (E) W	110	343	661	115	352	678
Sound power outlet (E) dB(A)	57	69	73	57	69	73
Sound power inlet + radiated (E) dB(A)	60	71,5	75	60	71,5	75
Sound pressure outlet (*) dB(A)	48	60	64	48	60	64
Sound pressure inlet + radiated (*) dB(A)	51	63	66	51	63	66
Plenum code	9034280			9034280		

(E) = EUROVENT certified performance.

(\*) = The sound pressure levels are 9 dB(A) lower than the sound power levels and apply to the reverberant field of a 100 m<sup>3</sup> room and a reverberation time of 0.5 sec.

**Kit 230 V**     **Main and auxiliary coil valve kit**  
 (to be used only QCV-MB2 control board, T-AUTO and IR-MB2S controls)  
 230 V, ON-OFF valve.



**Kit 24 V**     **Main and auxiliary coil valve kit**  
 (to be used only with QCV-MB2 control board)  
 Valve with 3 points - 24 Volt actuator.



**BCM**     **External auxiliary condensate collection tray**

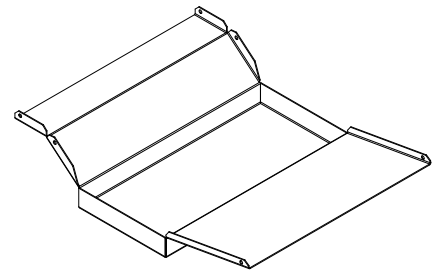

**BEM**     **Electric coil**  
 Consists of electric resistances and a security thermostat, which are inside a galvanized steel and insulated casing.

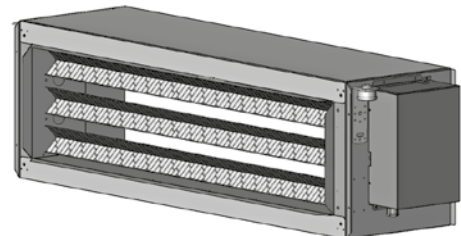

**PMM**     **Intake/supply spigot plenum**  
 Intake/supply spigot plenum with 3 spigots (Sizes 1 - 2 - 3) or 4 spigots (Sizes 4-5-6).

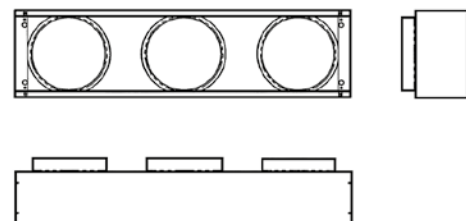

**SFM**     **ePM<sub>10</sub> 50% - G4 class synthetic filter**  
 The filter is a washable synthetic fibre, flame-proof according to Class F1 DIN 53438.  
 Compliant with: EN 16890.

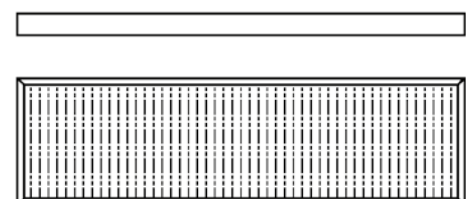

BFEL

---

**SFM-F6****ePM<sub>10</sub> 70% - F6 class Synthetic Filter**  
(for size 6 only)

High efficiency compact filter in glass microfiber paper. Compliant with: EN 16890.

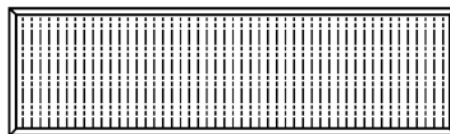
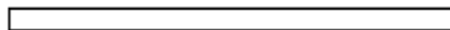

---

**GAV****Antivibrating connection**

Intake/supply antivibrating connection, made of two galvanized frames and a PVC flexible connection.

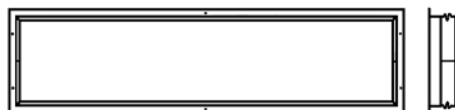

## Electronic wall controls

<b>T-AUTO</b>	Automatic speed control with electronic thermostat and summer/winter switch (to be used with T-POWER-M01 or T-POWER-A01 only)
<b>IR-MB2S</b>	IR-MB2S wall control (to be used with T-POWER-M01 or T-POWER-A01 only)
<b>T-POWER-M01</b>	Power unit for T-AUTO and IR-MB2S remote controls, fitted on the unit
<b>T-POWER-A01</b>	Power unit for T-AUTO and IR-MB2S remote controls, not fitted on the unit

## Electronic controls for MB boards

<b>QCV-MB2</b>	MB control panel version IR-MB2S wall control included)
<b>TODS</b>	TODS multifunction control panel (to be used with QCV-MB2 control panel only)

### NET management system for a network of fan coils

<b>ROUTER-A</b>	Router for BMS systems not provided by Trane
<b>ROB-A</b>	Relay output board



TRANE  
TECHNOLOGIES

---

Trane - by Trane Technologies (NYSE: TT), a global climate innovator - creates comfortable, energy efficient indoor environments for commercial and residential applications. For more information, please visit [www.trane.eu](http://www.trane.eu) or [www.tranetechnologies.com](http://www.tranetechnologies.com)

Trane has a policy of continuous product and product data improvement and reserves the right to change design and specifications without notice. We are committed to using environmentally conscious print practices.