



Fan coil unit
Cassette

CWS

CWE

CWE 7-8

TECHNICAL GUIDE



TABLE OF CONTENTS
Introduction

Introduction	p. 4
--------------	------

CWS

Main components	p. 5
EUROVENT Certifications	p. 6
Cooling emission	p. 8
Heating emission	p. 10
Water side pressure drop	p. 12
Operating limits	p. 13
Dimension and weight	p. 14
Air throw	p. 17
CWS controls	p. 18
CWS-EH version	p. 19
CWS-EH controls	p. 19
Air diffuser - DIFF	p. 20

CWE

Main components	p. 21
EUROVENT Certifications	p. 22
Cooling emission	p. 24
Heating emission	p. 26
Water side pressure drop	p. 28
Operating limits	p. 29
Dimension and weight	p. 30
Air throw	p. 33

CWE controls	p. 34
CWE-E version	p. 35
CWE-E control	p. 35

CWE 7-8

Main components	p. 36
EUROVENT Certifications	p. 38
Cooling emission	p. 39
Heating emission	p. 42
Water side pressure drop	p. 43
Operating limits	p. 44
Dimension and weight	p. 45
Air throw	p. 46
CWE 7-8 controls	p. 47
CWE 7-8-E version	p. 48

Controls

Controls	p. 49
----------	-------

Fresh air and FAC accessory

Fresh air and FAC accessory	p. 51
-----------------------------	-------

Accessories

Accessories	p. 52
-------------	-------

Filter

Electronic electrostatic filter	p. 66
---------------------------------	-------



Trane take part to the Eurovent program of fan coil performance certification. The official figures are published in the web site www.eurovent-certification.com. The tested performances are:

Total cooling emission at the following conditions:

• water temperature	+7 °C E.W.T.	+12 °C L.W.T.
• air temperature	+27 °C d.b.	+19 °C w.b.

Heating emission (2 pipe units) at the following conditions:

• water temperature	+45 °C E.W.T.	+40 °C L.W.T.
• air temperature	+20 °C	
Static pressure	Fan absorption	

Sensible cooling emission at the following conditions:

• water temperature	+7 °C E.W.T.	+12 °C L.W.T.
• air temperature	+27 °C d.b.	+19 °C w.b.

Heating emission (4 pipe units) at the following conditions:

• water temperature	+65 °C E.W.T.	+55 °C L.W.T.
• air temperature	+20 °C	
Water side pressure drop	Sound power	

INTRODUCTION

The Cassette fan coil units **CWS** serie (7 sizes), **CWE** serie (5 sizes) and **CWE 7-8** (2 sizes) are the result of an extended technical and design development aimed at achieving the highest level in terms of performance, silent operation and control possibility.

The full range has an innovative and beautiful design, high control flexibility and extremely easy maintenance, all this achieving the highest level in terms of performance suited to all dimension environments.

The air diffuser has an highly attractive aesthetical appearance, very innovative, and is also able to offer the best air distribution performance thanks to long computer studies and laboratory tests.

The standard colour is RAL 9003, other colours available on request.

All the models allow the best outcome in terms of quietness and of price/performance ratio.

Every unit can be supplied with 1 coil (2 pipe system) and a possible electric heater or with 2 coils (4 pipe system).

The Cassette is fitted with inlets for fresh air to be mixed with return air inside the unit.

The float switch centrifugal pump is particularly silent, with 650 mm of maximum head.

In addition to temperature and speed standard controls, automatic speed selection is also available. More than one unit can be connected to a single control.

All the units can be supplied in **MB** version. This version includes a wide range of controls, including the infra-red remote control, which allows managing one single unit or several units by using the Modbus RTU - RS 485 communication protocol. The units can be connected to the most common automatic building management systems.

With the CWE 7-8 MB version serie it is possible to control at the same time the (motorized) outlet louvers with the remote-control or with the IR-MB wall control.

The outlet louvers position themselves automatically according to the selected operation (summer-winter) and can be managed with the swing mode, that guarantees a complete air distribution in the environment.

ECM version

The **CWE** and **CWE 7-8** series use an innovative brushless synchronous permanent magnet electric motor controlled by an inverter board that is directly installed

on the unit.

The air flow can be varied continuously with a 1-10 V signal from Trane controls or by independent controllers (programmable controllers with a 1-10 V output).

The extreme efficiency, also at a low speed, makes possible a great reduction in electric consumption (more than 75% less in comparison to a traditional motor) with absorption values, under normal operating conditions, that are no greater than a 10 Watt for **CWE** serie and than 20 Watt for **CWE 7-8** serie.

The brushless motor is characterised by a constant synchronous speed, independently of the applied load, that depends only on the motor power supply frequency, which is modulated by the inverter.

It consumes less because:

- the motor always works at its point of maximum efficiency
- in the brushless motor, the rotor's permanent magnets generate the magnetising power autonomously
- the motor always operates at the synchronous speed, as a result there are no induced currents that reduce efficiency.

The main advantages are:

- large reduction in energy consumption, thanks to an optimal response to the thermal load of the environment during every moment of the day
- operating silence at all rotation speeds
- ability to operate at any rotation speed.

MAIN COMPONENTS



Air diffuser

Intake grids, frame and adjustable air distribution louvers on each side, made from ABS.

- DIFF version white ABS, RAL 9003.
- DIFF version with intake grid, frame and louvers, choice of one colour only.
- DIFFMD-600 / DIFFMD-800 version: metal diffuser painted in RAL 9003 white colour with 600x600 / 800x800 dimension to perfectly fit into the false ceiling standard modules without overlapping parts.

Inner casing

It is made of galvanized steel with internal thermal insulation with polyolefin (PO) foam (class M1) and external anti-condensate lining.

Control panel

Made of an external box with the control electronic board with an easily accessible terminal board.

Fan assembly

The fan assembly, which is mounted on anti-vibrating supports, is extremely silent.

The radial fan has been designed to optimise performance, using wing profile blades with a shape that reduces turbulence, increasing efficiency and reducing noise.

The motor is single phase 230 V / 50 Hz supply, class B insulation and integrated Klixon thermal contact for motor protection.

The units are supplied with 3 standard speeds connected and it is possible to change them on site if necessary.

Coil

Made of copper tubes with bonded aluminium fins for maximum transfer contact.

1, 2 or 3 row coil for 2 pipe models and 2+1 row coil for 4 pipe models (the heating row is on the inside part of the coil).

For 4 pipe systems two versions are available: the CWS 04-4P, CWS 14-4P, CWS 24-4P, CWS 34-4P, CWS 44-4P, CWS 54-4P, CWS 64-4P serie supply an higher heating emission; and the CWS 26-4P, CWS 36-4P, CWS 56-4P,

CWS 66-4P serie supply an higher cooling emission. The coil is not suitable for use in corrosive atmosphere or in environments where aluminium may be subject to corrosion.

Condensate collection tray

High density ABS polystyrene foam condensate tray, shaped in order to optimize the air diffusion. Fire retardant rating B1 to DIN 4102.

Filter

Synthetic washable filter, easily removable.

Condensate pump

Float switch centrifugal pump with 650 mm of maximum head, integral to the unit and wired to the control panel on the outside of the casing.

Valve set

Two or three way valves for ON/OFF operation, with pipe mounting kit and lockshields.



EUROVENT CERTIFICATIONS

2 pipe system

The following standard rating conditions are used:

COOLING

Entering air temperature: + 27 °C d.b. + 19 °C w.b.
Water temperature: +7 °C E.W.T. +12 °C L.W.T.

HEATING

Entering air temperature: + 20 °C
Water temperature: +45 °C E.W.T. +40 °C L.W.T.

MODEL	Speed	CWS 02-2P			CWS 12-2P			CWS 22-2P			CWS 32-2P		
		1 MIN	2 MED	3 MAX	1 MIN	2 MED	3 MAX	1 MIN	2 MED	3 MAX	1 MIN	2 MED	3 MAX
Air flow	m ³ /h	310	420	610	310	420	520	320	500	710	430	610	880
Cooling total emission (E)	kW	1,25	1,60	1,92	1,82	2,31	2,64	2,23	3,30	4,26	2,91	3,82	4,93
Cooling sensible emission (E)	kW	0,99	1,29	1,58	1,33	1,72	2,00	1,55	2,35	3,11	2,05	2,75	3,65
Heating emission (E)	kW	1,38	1,80	2,24	1,85	2,42	2,80	2,12	3,28	4,37	2,85	3,85	5,15
Dp Cooling (E)	kPa	4,5	7,0	10,0	4,9	7,6	9,7	6,4	13,0	20,9	7,5	12,4	19,7
Dp Heating (E)	kPa	4,4	7,2	10,7	4,3	6,9	9,0	2,8	6,1	10,2	6,2	10,6	17,8
Sound power (Lw) (E)	dB(A)	33	40	49	33	40	45	33	45	53	41	49	59
Sound pressure (Lp) ⁽¹⁾	dB(A)	24	31	40	24	31	36	24	36	44	32	40	50
Motor power input (E)	W	25	32	57	25	32	44	25	44	68	32	57	90
Current absorbed	A	0,11	0,15	0,27	0,11	0,15	0,20	0,11	0,20	0,32	0,15	0,27	0,45
Condensate drain pump power absorption	W	10	10	10	10	10	10	10	10	10	10	10	10
Water content	l	0,8	0,8	0,8	1,4	1,4	1,4	2,1	2,1	2,1	2,1	2,1	2,1
Length	mm	575	575	575	575	575	575	575	575	575	575	575	575
Depth	mm	575	575	575	575	575	575	575	575	575	575	575	575
Height	mm	275	275	275	275	275	275	275	275	275	275	275	275

MODEL	Speed	CWS 42-2P			CWS 52-2P			CWS 62-2P		
		1 MIN	2 MED	3 MAX	1 MIN	2 MED	3 MAX	1 MIN	2 MED	3 MAX
Air flow	m ³ /h	630	820	1140	710	970	1500	710	1280	1820
Cooling total emission (E)	kW	4,18	4,86	6,08	5,27	6,72	9,39	5,27	8,36	10,93
Cooling sensible emission (E)	kW	3,00	3,53	4,51	3,42	4,42	6,36	3,67	6,00	8,08
Heating emission (E)	kW	4,27	5,03	6,50	4,92	6,40	9,23	5,12	8,55	11,72
Dp Cooling (E)	kPa	10,9	14,3	21,6	9,4	14,7	26,9	9,4	21,8	35,6
Dp Heating (E)	kPa	7,0	9,4	15,0	7,1	11,4	22,0	7,6	19,2	33,8
Sound power (Lw) (E)	dB(A)	33	40	48	34	40	53	34	48	58
Sound pressure (Lp) ⁽¹⁾	dB(A)	24	31	39	25	31	44	25	39	49
Motor power input (E)	W	33	48	77	42	63	120	42	95	170
Current absorbed	A	0,15	0,23	0,36	0,18	0,28	0,53	0,18	0,42	0,74
Condensate drain pump power absorption	W	10	10	10	10	10	10	10	10	10
Water content	l	3,0	3,0	3,0	4,0	4,0	4,0	4,0	4,0	4,0
Length	mm	820	820	820	820	820	820	820	820	820
Depth	mm	820	820	820	820	820	820	820	820	820
Height	mm	303	303	303	303	303	303	303	303	303

(E) Eurovent certified performance (MIN-MED-MAX speed)
(1) The sound pressure levels are 9 dB (A) lower than the sound power levels, apply to the reverberant field of a 100 m³ room and a reverberation time of 0.5 sec.



4 pipe system

The following standard rating conditions are used:

COOLING

Entering air temperature: + 27 °C d.b. + 19 °C w.b.
Water temperature: +7 °C E.W.T. +12 °C L.W.T.

HEATING

Entering air temperature: + 20 °C
Water temperature: +65 °C E.W.T. +55 °C L.W.T.

MODEL	Speed	CWS 04-4P			CWS 14-4P			CWS 24-4P			CWS 26-4P			CWS 34-4P			CWS 36-4P		
		1	2	3	1	2	3	1	2	3	1	2	3	1	2	3	1	2	3
		MIN	MED	MAX	MIN	MED	MAX	MIN	MED	MAX	MIN	MED	MAX	MIN	MED	MAX	MIN	MED	MAX
Air flow	m ³ /h	310	420	610	310	420	520	320	500	710	320	500	710	430	610	880	430	610	880
Cooling total emission (E)	kW	1,49	1,93	2,27	1,83	2,33	2,66	1,83	2,61	3,27	2,07	3,02	3,86	2,33	2,96	3,72	2,69	3,47	4,44
Cooling sensible emission (E)	kW	1,13	1,52	1,84	1,32	1,68	1,94	1,32	1,94	2,49	1,47	2,20	2,88	1,72	2,23	2,88	1,94	2,56	3,37
Heating emission (E)	kW	1,72	2,23	2,66	2,13	2,66	3,04	2,13	3,04	3,86	1,73	2,71	2,91	2,61	3,33	4,19	2,14	2,66	3,29
Dp Cooling (E)	kPa	6,0	10,0	13,5	4,6	6,9	8,8	4,6	8,8	13,4	4,0	7,0	10,5	7,2	11,2	17,0	6,0	9,0	14,0
Dp Heating (E)	kPa	5,2	8,3	11,4	4,6	6,8	8,7	4,6	8,7	13,3	2,6	4,6	6,7	6,4	9,9	15,0	3,9	5,7	8,4
Sound power (Lw) (E)	dB(A)	33	40	49	33	40	45	33	45	53	33	45	53	41	49	59	41	49	59
Sound pressure (Lp) ⁽¹⁾	dB(A)	24	31	40	24	31	36	24	36	44	24	36	44	32	40	50	32	40	50
Motor power input (E)	W	25	32	57	25	32	44	25	44	68	25	44	68	32	57	90	32	57	90
Current absorbed	A	0,11	0,15	0,27	0,11	0,15	0,20	0,11	0,20	0,32	0,11	0,20	0,32	0,15	0,27	0,45	0,15	0,27	0,45
Condensate drain pump power absorption	W	10	10	10	10	10	10	10	10	10	10	10	10	10	10	10	10	10	10
Cooling water content	l	1,0	1,0	1,0	1,4	1,4	1,4	1,4	1,4	1,4	1,7	1,7	1,7	1,4	1,4	1,4	1,7	1,7	1,7
Heating water content	l	0,6	0,6	0,6	0,7	0,7	0,7	0,7	0,7	0,7	0,5	0,5	0,5	0,7	0,7	0,7	0,5	0,5	0,5
Length	mm	575	575	575	575	575	575	575	575	575	575	575	575	575	575	575	575	575	575
Depth	mm	575	575	575	575	575	575	575	575	575	575	575	575	575	575	575	575	575	575
Height	mm	275	275	275	275	275	275	275	275	275	275	275	275	275	275	275	275	275	275

MODEL	Speed	CWS 44-4P			CWS 54-4P			CWS 56-4P			CWS 64-4P			CWS 66-4P		
		1	2	3	1	2	3	1	2	3	1	2	3	1	2	3
		MIN	MED	MAX	MIN	MED	MAX	MIN	MED	MAX	MIN	MED	MAX	MIN	MED	MAX
Air flow	m ³ /h	630	820	1140	710	970	1500	710	970	1500	710	1280	1820	710	1280	1820
Cooling total emission (E)	kW	4,11	4,98	6,26	4,48	5,60	7,59	4,95	6,27	8,65	4,48	6,84	8,72	4,95	7,75	9,69
Cooling sensible emission (E)	kW	2,93	3,60	4,61	3,21	4,09	5,71	3,49	4,49	6,37	3,21	5,09	6,67	3,49	5,64	7,26
Heating emission (E)	kW	5,21	6,33	8,02	5,69	7,15	9,66	4,59	5,63	7,50	5,69	8,80	11,16	4,59	6,78	9,48
Dp Cooling (E)	kPa	8,8	12,5	18,9	10,3	15,4	26,9	9,0	14,0	25,0	10,3	22,1	34,7	9,0	20,0	32,0
Dp Heating (E)	kPa	7,9	11,2	17,2	9,3	14,0	24,0	4,9	7,0	11,8	9,3	20,3	31,2	4,9	9,9	15,0
Sound power (Lw) (E)	dB(A)	33	40	48	34	40	53	34	40	53	34	48	58	34	48	58
Sound pressure (Lp) ⁽¹⁾	dB(A)	24	31	39	25	31	44	25	31	44	25	39	49	25	39	49
Motor power input (E)	W	33	48	77	42	63	120	42	63	120	42	95	170	42	95	170
Current absorbed	A	0,15	0,23	0,36	0,18	0,28	0,53	0,18	0,28	0,53	0,18	0,42	0,74	0,18	0,42	0,74
Condensate drain pump power absorption	W	10	10	10	10	10	10	10	10	10	10	10	10	10	10	10
Cooling water content	l	3,0	3,0	3,0	3,0	3,0	3,0	3,6	3,6	3,6	3,0	3,0	3,0	3,6	3,6	3,6
Heating water content	l	1,4	1,4	1,4	1,4	1,4	1,4	1,0	1,0	1,0	1,4	1,4	1,4	1,1	1,1	1,1
Length	mm	820	820	820	820	820	820	820	820	820	820	820	820	820	820	820
Depth	mm	820	820	820	820	820	820	820	820	820	820	820	820	820	820	820
Height	mm	303	303	303	303	303	303	303	303	303	303	303	303	303	303	303

(E) Eurovent certified performance (MIN-MED-MAX speed)

(1) The sound pressure levels are 9 dB (A) lower than the sound power levels, apply to the reverberant field of a 100 m³ room and a reverberation time of 0.5 sec.

COOLING EMISSION

Models with single coil (2 pipe installations)

Entering air temperature: +27 °C d.b. – +19 °C w.b.

Model	Vn	Qv m ³ /h	WT: 7 / 12 °C			WT: 8 / 13 °C			WT: 9 / 14 °C			WT: 12 / 17 °C		
			Pc kW	Ps kW	Qw l/h	Pc kW	Ps kW	Qw l/h	Pc kW	Ps kW	Qw l/h	Pc kW	Ps kW	Qw l/h
CWS 02-2P	3 MAX	610	1,92	1,58	340	1,75	1,50	310	1,41	1,39	254	1,10	1,10	199
	2 MED	420	1,60	1,29	280	1,42	1,19	250	1,22	1,16	210	0,90	0,90	160
	1 MIN	310	1,25	0,99	219	1,09	0,88	191	0,96	0,89	165	0,69	0,69	123
CWS 12-2P	3 MAX	520	2,64	2,00	462	2,34	1,82	409	2,10	1,75	362	1,43	1,43	252
	2 MED	420	2,31	1,72	403	2,05	1,58	358	1,84	1,50	317	1,25	1,25	220
	1 MIN	310	1,82	1,30	317	1,62	1,22	282	1,61	1,29	276	1,07	1,07	188
CWS 22-2P	3 MAX	710	4,26	3,11	745	3,81	2,87	668	3,59	2,87	617	2,37	2,37	420
	2 MED	500	3,30	2,35	575	2,97	2,18	518	2,81	2,18	483	1,82	1,82	319
	1 MIN	320	2,23	1,55	387	2,01	1,43	350	2,03	1,53	349	1,29	1,29	225
CWS 32-2P	3 MAX	880	4,93	3,65	863	4,38	3,35	769	4,03	3,29	694	2,70	2,70	479
	2 MED	610	3,82	2,75	667	3,44	2,55	601	3,25	2,57	559	2,13	2,13	376
	1 MIN	430	2,91	2,05	506	2,62	1,90	456	2,50	1,92	430	1,62	1,62	283
CWS 42-2P	3 MAX	1140	6,08	4,40	1060	5,39	4,14	940	4,88	3,95	840	3,25	3,25	573
	2 MED	820	4,86	3,45	845	4,33	3,25	753	3,92	3,09	674	2,58	2,58	453
	1 MIN	630	4,18	2,94	722	3,73	2,76	647	3,37	2,62	580	2,20	2,20	384
CWS 52-2P	3 MAX	1500	9,39	6,36	1635	8,48	6,33	1480	7,57	5,99	1301	5,00	5,00	880
	2 MED	970	6,72	4,42	1166	6,10	4,41	1060	5,46	4,15	939	3,50	3,50	612
	1 MIN	710	5,27	3,42	913	4,79	3,40	830	4,30	3,20	740	2,48	2,48	434
CWS 62-2P	3 MAX	1820	10,93	7,90	1909	9,83	7,48	1721	8,78	7,11	1511	5,90	5,90	1044
	2 MED	1280	8,36	5,89	1454	7,59	5,59	1321	6,75	5,27	1162	4,42	4,42	775
	1 MIN	710	5,27	3,60	913	4,79	3,40	830	4,30	3,20	740	2,48	2,48	434

WT: Water temperature
Vn: Nominal speeds
Qv: Air flow
Pc: Cooling total emission
Ps: Cooling sensible emission
Qw: Water flow rate

Models with double coil (4 pipe installations)

Note: the CWS 26-4P - 36-4P - 56-4P - 66-4P versions are equipped with an extra cold battery.

Entering air temperature: +27 °C d.b. – +19 °C w.b.

Model	Vn	Qv m ³ /h	WT: 7 / 12 °C			WT: 8 / 13 °C			WT: 9 / 14 °C			WT: 12 / 17 °C			
			Pc kW	Ps kW	Qw l/h	Pc kW	Ps kW	Qw l/h	Pc kW	Ps kW	Qw l/h	Pc kW	Ps kW	Qw l/h	
CWS 04-4P	3	MAX	610	2,27	1,84	401	2,04	1,73	361	1,78	1,69	307	1,33	1,33	239
	2	MED	420	1,93	1,52	337	1,73	1,43	303	1,51	1,37	260	1,11	1,11	196
	1	MIN	310	1,49	1,13	260	1,34	1,06	234	1,17	1,02	201	0,84	0,84	148
CWS 14-4P	3	MAX	520	2,66	1,94	465	2,36	1,82	413	2,18	1,79	374	1,47	1,47	260
	2	MED	420	2,33	1,68	405	2,06	1,57	360	1,80	1,44	309	1,19	1,19	210
	1	MIN	310	1,83	1,32	318	1,63	1,21	284	1,55	1,22	267	1,01	1,01	177
CWS 24-4P	3	MAX	710	3,27	2,49	574	2,88	2,28	507	2,72	2,30	467	1,85	1,85	330
	2	MED	500	2,61	1,94	455	2,30	1,78	404	2,18	1,79	374	1,47	1,47	260
	1	MIN	320	1,83	1,32	318	1,63	1,21	284	1,55	1,22	267	1,01	1,01	177
CWS 26-4P	3	MAX	710	3,86	2,88	664	3,49	2,70	613	3,00	2,53	528	2,13	2,13	378
	2	MED	500	3,02	2,20	519	2,75	2,06	480	2,37	1,93	415	1,63	1,63	288
	1	MIN	320	2,07	1,47	355	1,89	1,37	329	1,65	1,29	287	1,10	1,10	192
CWS 34-4P	3	MAX	880	3,72	2,88	656	3,25	2,62	574	2,98	2,56	512	2,04	2,04	366
	2	MED	610	2,96	2,23	520	2,62	2,05	461	2,40	2,00	413	1,61	1,61	288
	1	MIN	430	2,33	1,72	405	2,06	1,57	360	1,96	1,59	337	1,32	1,32	231
CWS 36-4P	3	MAX	880	4,44	3,37	764	3,99	3,14	702	3,43	2,96	606	2,48	2,48	442
	2	MED	610	3,47	2,56	597	3,16	2,41	554	2,71	2,25	477	1,90	1,90	337
	1	MIN	430	2,69	1,94	462	2,45	1,82	427	2,12	1,70	370	1,46	1,46	256
CWS 44-4P	3	MAX	1140	6,26	4,50	1090	5,58	4,25	973	5,02	4,04	864	3,33	3,33	586
	2	MED	820	4,98	3,52	866	4,46	3,32	776	4,02	3,15	691	2,63	2,63	462
	1	MIN	630	4,11	2,87	713	3,69	2,71	640	3,33	2,56	572	2,14	2,14	374
CWS 54-4P	3	MAX	1500	7,59	5,57	1327	6,71	5,23	1175	6,08	5,02	1046	4,10	4,10	726
	2	MED	970	5,60	4,00	974	5,00	3,77	871	4,50	3,57	775	2,99	2,99	524
	1	MIN	710	4,48	3,15	778	4,01	2,97	698	3,62	2,81	623	2,35	2,35	411
CWS 56-4P	3	MAX	1500	8,65	6,37	1488	8,05	6,05	1405	6,79	5,60	1189	4,74	4,74	836
	2	MED	970	6,27	4,49	1078	5,86	4,27	1018	4,98	3,94	867	3,35	3,35	587
	1	MIN	710	4,95	3,49	851	4,62	3,31	802	3,96	3,06	689	2,63	2,63	459
CWS 64-4P	3	MAX	1820	8,72	6,49	1529	7,64	6,07	1344	6,97	5,98	1199	4,77	4,77	849
	2	MED	1280	6,84	4,96	1191	6,08	4,67	1062	5,48	4,46	942	3,66	3,66	646
	1	MIN	710	4,48	3,15	778	4,01	2,97	698	3,62	2,81	623	2,35	2,35	411
CWS 66-4P	3	MAX	1820	10,03	7,51	1725	9,28	7,11	1625	7,82	6,60	1375	5,57	5,57	987
	2	MED	1280	7,75	5,64	1332	7,24	5,37	1261	6,11	4,96	1066	4,21	4,21	739
	1	MIN	710	4,95	3,49	851	4,62	3,31	802	3,96	3,06	689	2,63	2,63	459

WT: Water temperature
Vn: Nominal speeds
Qv: Air flow
Pc: Cooling total emission
Ps: Cooling sensible emission
Qw: Water flow rate

HEATING EMISSION

Models with single coil (2 pipe installations)

Entering air temperature: +20 °C

Model	Vn	Qv m ³ /h	WT: 80 / 70 °C		WT: 70 / 60 °C		WT: 60 / 50 °C		WT: 50 / 40 °C		WT: 45 / 40 °C	
			Ph kW	Qw l/h	Ph kW	Qw l/h	Ph kW	Qw l/h	Ph kW	Qw l/h	Ph kW	Qw l/h
CWS 02-2P	3 MAX	610	5,67	488	4,56	393	3,46	298	2,37	203	2,24	386
	2 MED	420	4,55	391	3,66	315	2,78	239	1,91	164	1,80	310
	1 MIN	310	3,47	298	2,80	240	2,13	183	1,46	126	1,38	237
CWS 12-2P	3 MAX	520	6,97	599	5,68	488	4,39	377	3,10	266	2,80	482
	2 MED	420	5,96	513	4,91	422	3,80	327	2,69	232	2,42	417
	1 MIN	310	5,12	441	4,19	360	3,25	279	2,31	198	2,07	356
CWS 22-2P	3 MAX	710	11,30	972	9,25	795	7,19	619	5,12	440	4,57	787
	2 MED	500	8,48	730	6,96	598	5,43	467	3,89	334	3,45	593
	1 MIN	320	5,87	505	4,83	415	3,79	326	2,73	235	2,39	412
CWS 32-2P	3 MAX	880	13,00	1118	10,63	914	8,25	709	5,86	504	5,25	903
	2 MED	610	10,07	866	8,25	709	6,42	552	4,58	394	4,08	702
	1 MIN	430	7,43	639	6,10	524	4,77	410	3,42	294	3,02	520
CWS 42-2P	3 MAX	1140	16,08	1383	13,14	1130	10,21	878	7,26	624	6,50	1118
	2 MED	820	12,41	1067	10,16	874	7,92	681	5,65	486	5,03	865
	1 MIN	630	10,50	903	8,61	741	6,72	578	4,82	415	4,27	734
CWS 52-2P	3 MAX	1500	24,08	2071	19,76	1699	15,43	1327	11,06	951	9,78	1683
	2 MED	970	16,32	1403	13,43	1155	10,54	906	7,62	655	6,67	1146
	1 MIN	710	12,42	1068	10,25	882	8,07	694	5,87	505	5,09	876
CWS 62-2P	3 MAX	1820	28,91	2486	23,68	2037	18,45	1586	13,17	1132	11,72	2015
	2 MED	1280	21,01	1807	17,26	1484	13,50	1161	9,70	834	8,55	1471
	1 MIN	710	12,42	1068	10,25	882	8,07	694	5,87	505	5,09	876

WT: Water temperature
Vn: Nominal speeds
Qv: Air flow
Ph: Heating emission
Qw: Water flow rate

Models with double coil (4 pipe installations)

Note: the CWS 26-4P - 36-4P - 56-4P - 66-4P versions are equipped with an extra cold battery.

Entering air temperature: +20 °C

Model	Vn	Qv m ³ /h	WT: 80 / 70 °C		WT: 70 / 60 °C		WT: 60 / 50 °C		WT: 50 / 40 °C		WT: 45 / 40 °C		
			Ph kW	Qw l/h	Ph kW	Qw l/h	Ph kW	Qw l/h	Ph kW	Qw l/h	Ph kW	Qw l/h	Ph kW
CWS 04-4P	3	MAX	610	3,78	325	3,03	261	2,29	197	1,56	134	1,49	256
	2	MED	420	3,17	272	2,54	219	1,93	166	1,31	113	1,25	215
	1	MIN	310	2,44	210	1,96	169	1,49	128	1,01	87	0,96	166
CWS 14-4P	3	MAX	520	4,17	358	3,46	298	2,54	218	1,73	149	1,65	283
	2	MED	420	3,63	312	3,02	260	2,22	191	1,51	130	1,44	247
	1	MIN	310	2,87	247	2,43	209	1,76	151	1,20	103	1,14	196
CWS 24-4P	3	MAX	710	5,17	444	4,40	378	3,14	270	2,14	184	2,04	351
	2	MED	500	4,07	350	3,46	298	2,48	214	1,69	146	1,61	277
	1	MIN	320	2,87	247	2,43	209	1,76	151	1,20	103	1,14	196
CWS 26-4P	3	MAX	710	4,22	363	3,35	288	2,48	213	1,61	139	1,62	279
	2	MED	500	3,42	294	2,71	233	2,01	173	1,32	113	1,32	226
	1	MIN	320	2,49	214	1,98	170	1,47	127	0,97	83	0,96	165
CWS 34-4P	3	MAX	880	5,93	510	4,95	426	3,60	310	2,45	211	2,34	402
	2	MED	610	4,67	401	3,97	341	2,84	244	1,94	166	1,84	317
	1	MIN	430	3,63	312	3,10	267	2,22	191	1,51	130	1,44	247
CWS 36-4P	3	MAX	880	4,78	411	3,79	326	2,80	241	1,82	156	1,83	315
	2	MED	610	3,86	332	3,06	263	2,27	195	1,48	127	1,48	255
	1	MIN	430	3,10	266	2,46	212	1,83	157	1,20	103	1,19	205
CWS 44-4P	3	MAX	1140	11,28	970	9,10	783	6,93	596	4,76	410	4,48	771
	2	MED	820	8,90	766	7,19	618	5,48	471	3,77	324	3,54	609
	1	MIN	630	7,31	629	5,91	508	4,51	388	3,11	267	2,91	501
CWS 54-4P	3	MAX	1500	13,60	1170	11,00	946	8,34	718	5,73	493	5,40	929
	2	MED	970	10,04	864	8,10	697	6,17	531	4,25	365	3,99	686
	1	MIN	710	7,98	686	6,45	555	4,92	423	3,39	291	3,18	547
CWS 56-4P	3	MAX	1500	10,69	919	8,56	736	6,44	554	4,33	493	4,18	720
	2	MED	970	8,01	689	6,42	552	4,84	416	3,27	365	3,14	541
	1	MIN	710	6,52	561	5,23	450	3,95	340	2,67	291	2,56	441
CWS 64-4P	3	MAX	1820	15,74	1353	12,70	1092	9,64	829	6,61	569	6,24	1074
	2	MED	1280	12,37	1064	9,98	858	7,60	653	5,22	449	4,91	845
	1	MIN	710	7,98	686	6,45	555	4,92	423	3,39	291	3,18	547
CWS 66-4P	3	MAX	1820	12,24	1053	9,80	843	7,36	633	6,61	569	4,79	824
	2	MED	1280	9,66	831	7,74	666	5,83	501	5,22	449	3,79	651
	1	MIN	710	6,52	561	5,23	450	3,95	340	3,39	291	2,56	441

WT: Water temperature
Vn: Nominal speeds
Qv: Air flow
Ph: Heating emission
Qw: Water flow rate

WATER SIDE PRESSURE DROP

2 pipe system

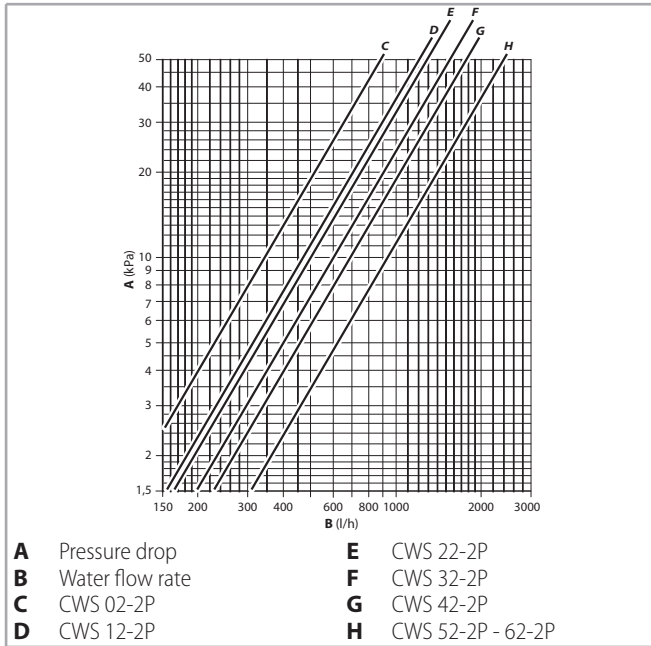

Pressure drop for mean water temperature of 10 °C, for different temperatures multiply the pressure drop figure by the K correction factors in the table.

K correction factor	Mean water temperature (°C)						
	20	30	40	50	60	70	80
	0,94	0,90	0,86	0,82	0,78	0,74	0,70

4 pipe system

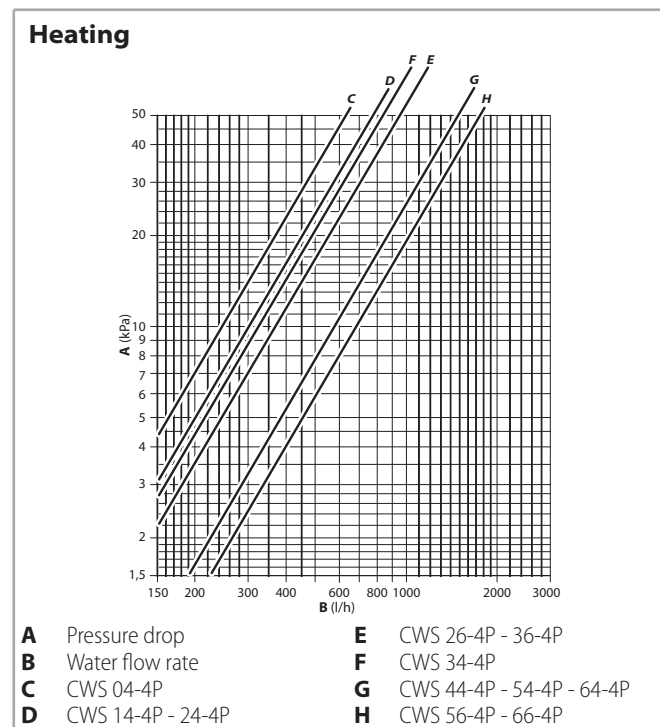
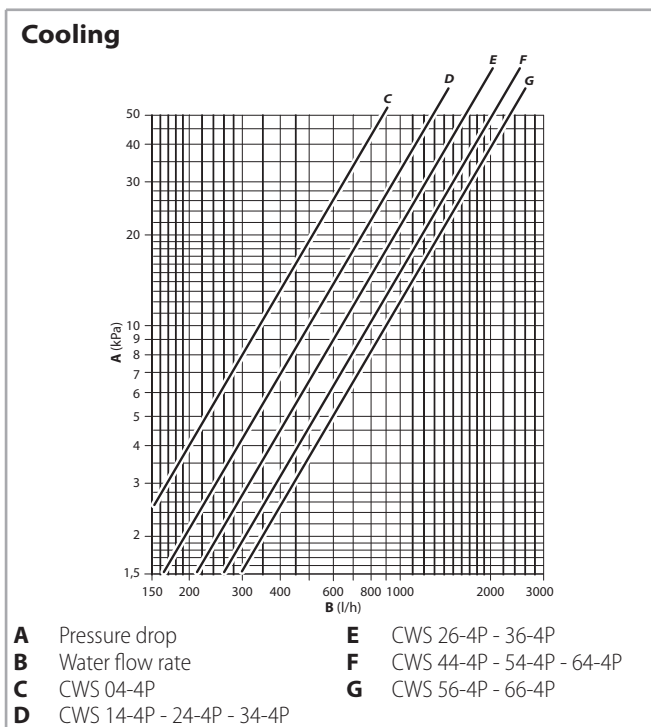

Pressure drop for mean water temperature of 10 °C, for different temperatures multiply the pressure drop figure by the K correction factors in the table.

K correction factor	Mean water temperature (°C)						
	20	30	40	50	60	70	80
	0,94	0,90	0,86	0,82	0,78	0,74	0,70

Pressure drop for mean water temperature of 60 °C, for different temperatures multiply the pressure drop figure by the K correction factors in the table.

K correction factor	Mean water temperature (°C)			
	40	50	70	80
	1,12	1,06	0,94	0,88

OPERATING LIMITS

Description		UoM	Value
Water flow	Highest working pressure	bars	10
		kPa	1000
	Lowest water inlet temperature	°C	+6
	Highest water inlet temperature	°C	+80
Power supply	Single-phase rated operating voltage	V/Hz	230/50

For maximum installation height, see p. 17.



DIMENSION AND WEIGHT

CWS 0 / 1 / 2 / 3 (600 x 600 version)

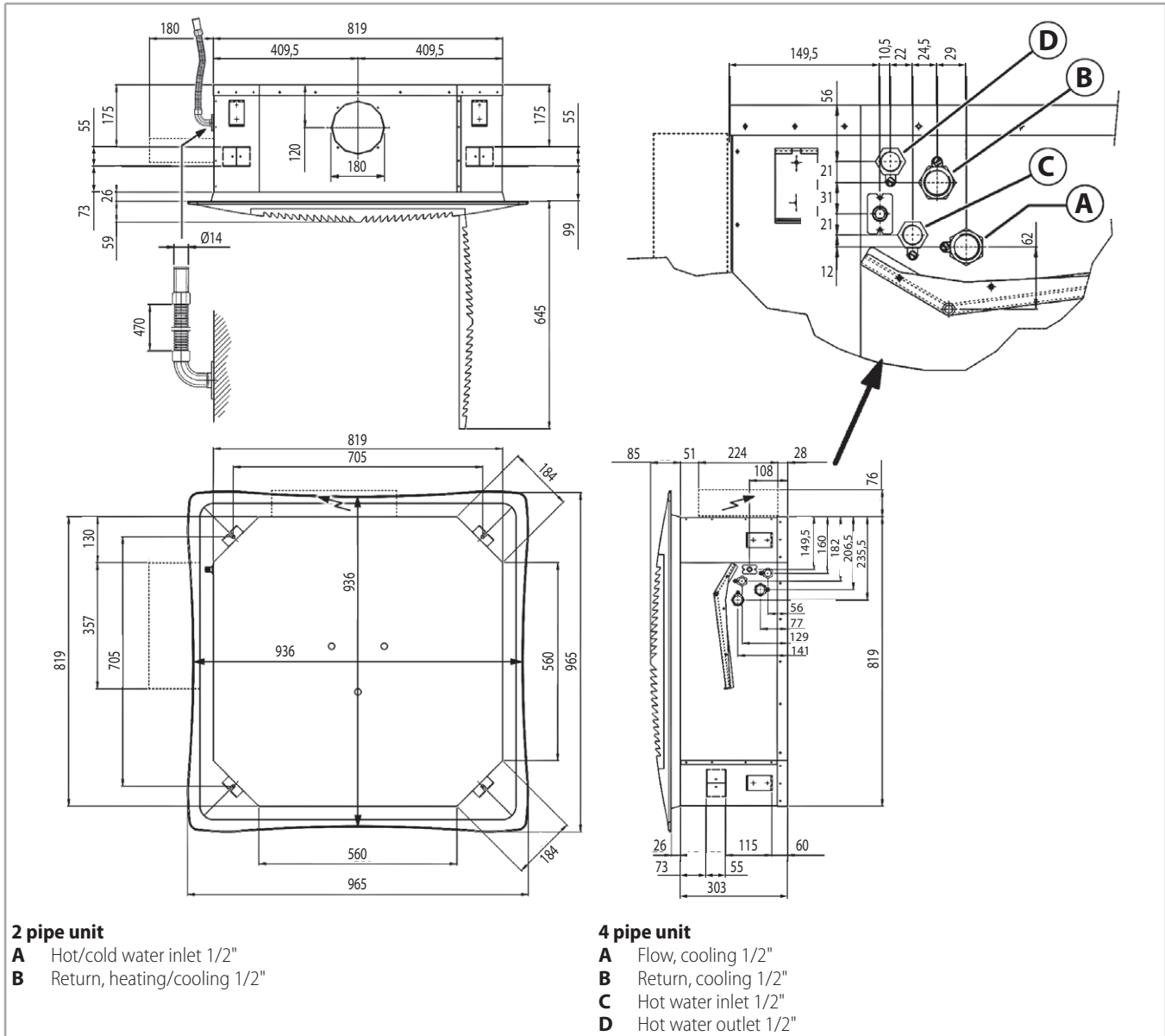

Packed unit

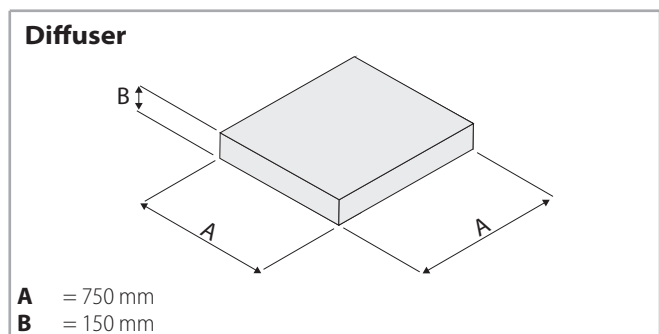
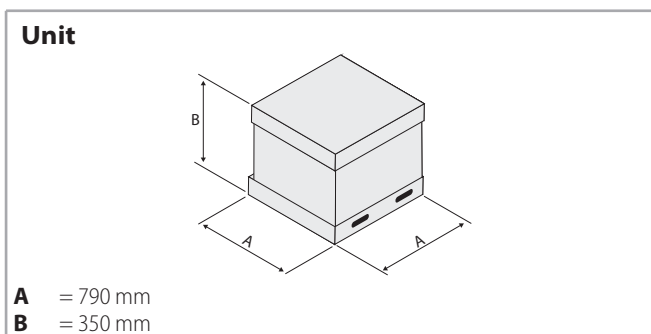

Weight/Model		02-2P - 12-2P	04-4P - 14-4P	22-2P-24-4P-26-4P	32-2P-34-4P-36-4P
With packaging	kg	28		30	
Without packaging	kg	22		24	

Weight/Model		02-2P - 12-2P	04-4P - 14-4P	22-2P-24-4P-26-4P	32-2P-34-4P-36-4P
With packaging	kg			6	
Without packaging	kg			3	

CWS 4 / 5 / 6 (800 x 800 version)

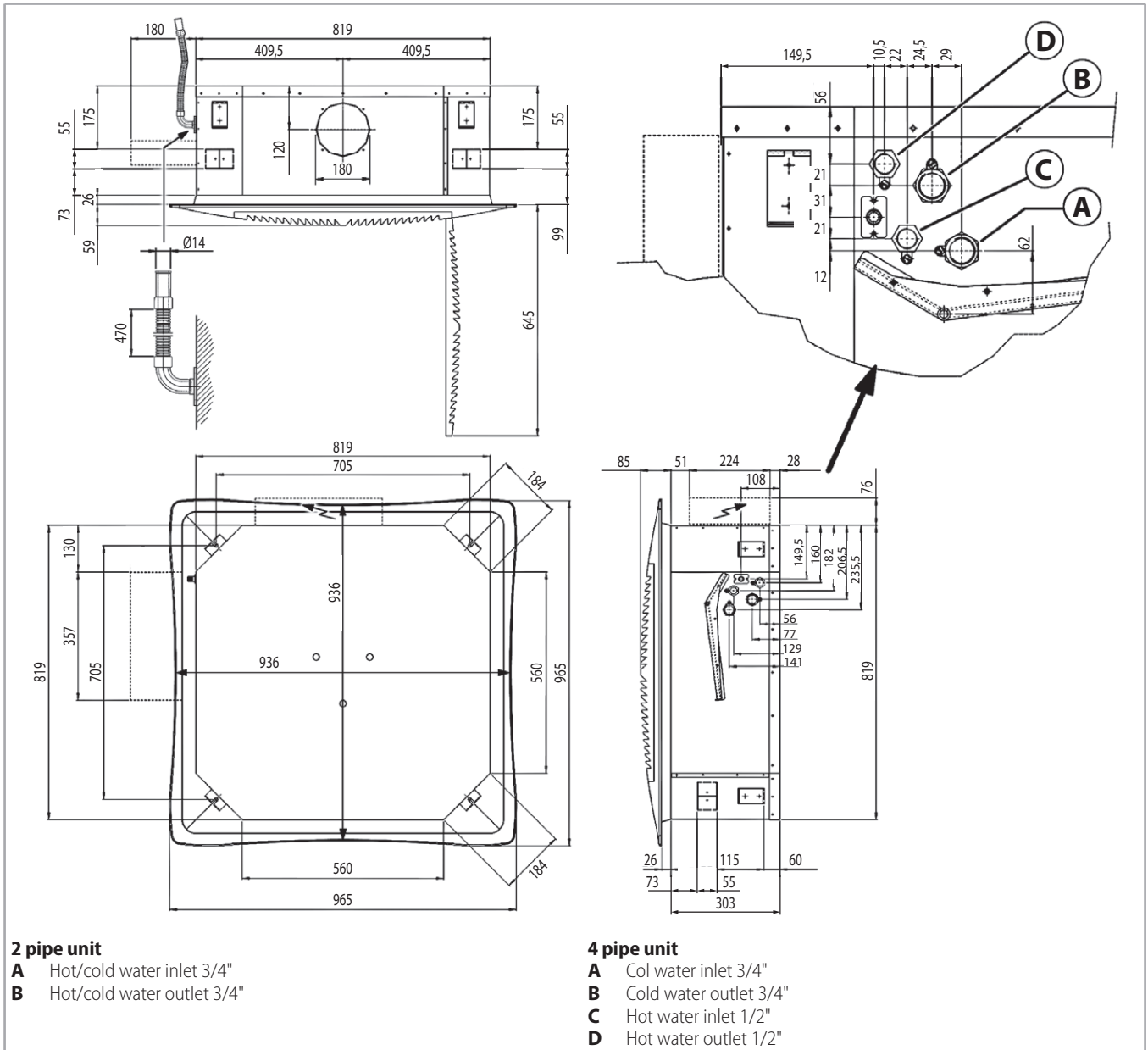

Packed unit

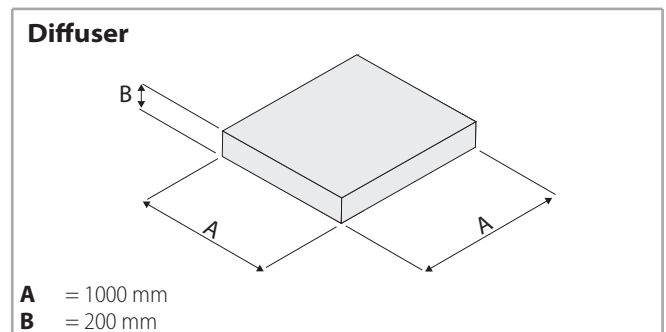
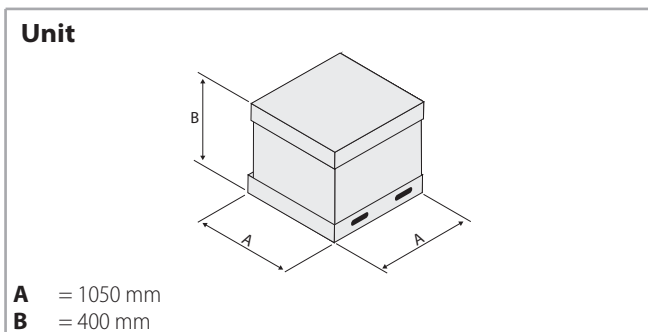

Weight/Model		42-2P	44-4P	52-2P-54-4P-56-4P	62-2P-64-4P-66-4P
With packaging	kg	44		47	
Without packaging	kg	36		39	

Weight/Model		42-2P	44-4P	52-2P-54-4P-56-4P	62-2P-64-4P-66-4P
With packaging	kg			10	
Without packaging	kg			6	

DIFFMD-600 / DIFFMD-800 metal air inlet grid

(REC-AD receiver, Code 9066338, for DIFFMD-600 / DIFFMD-800 metal diffuser for MB units)
 Not suitable with electronic electrostatic filter.

Model	Code
DIFFMD-600	9079420
DIFFMD-800	9079417

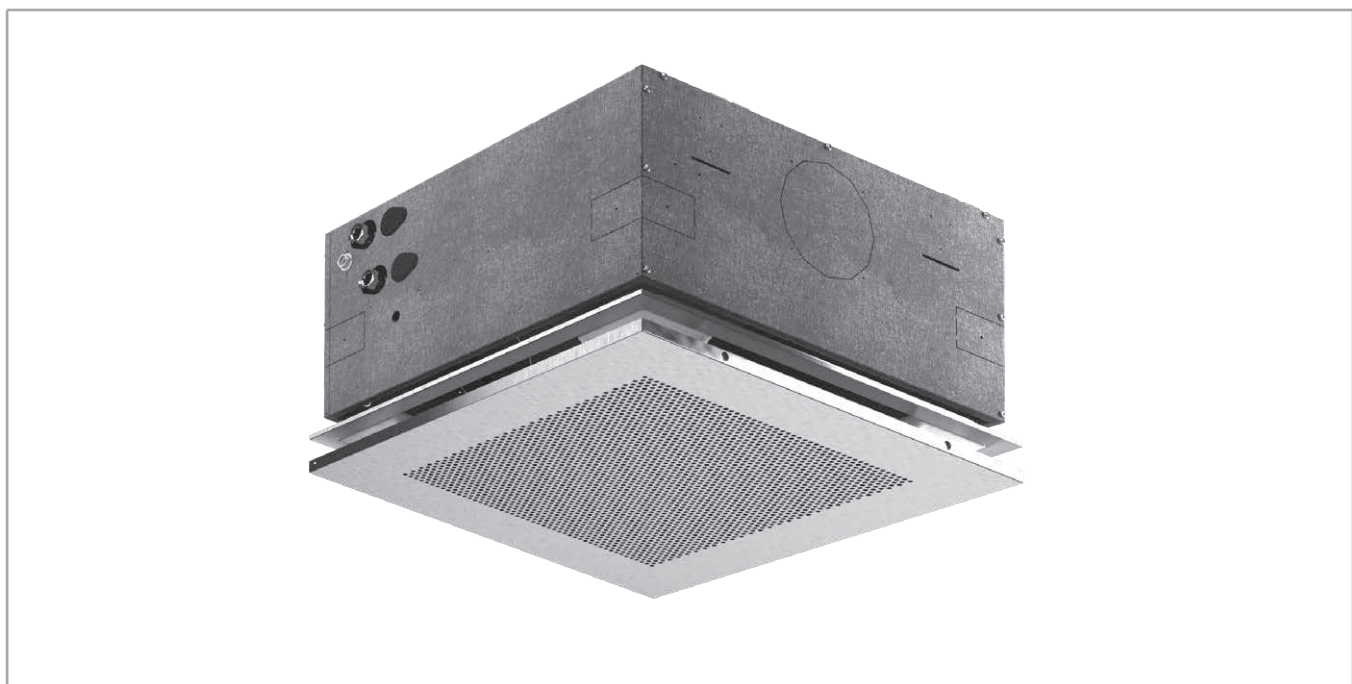
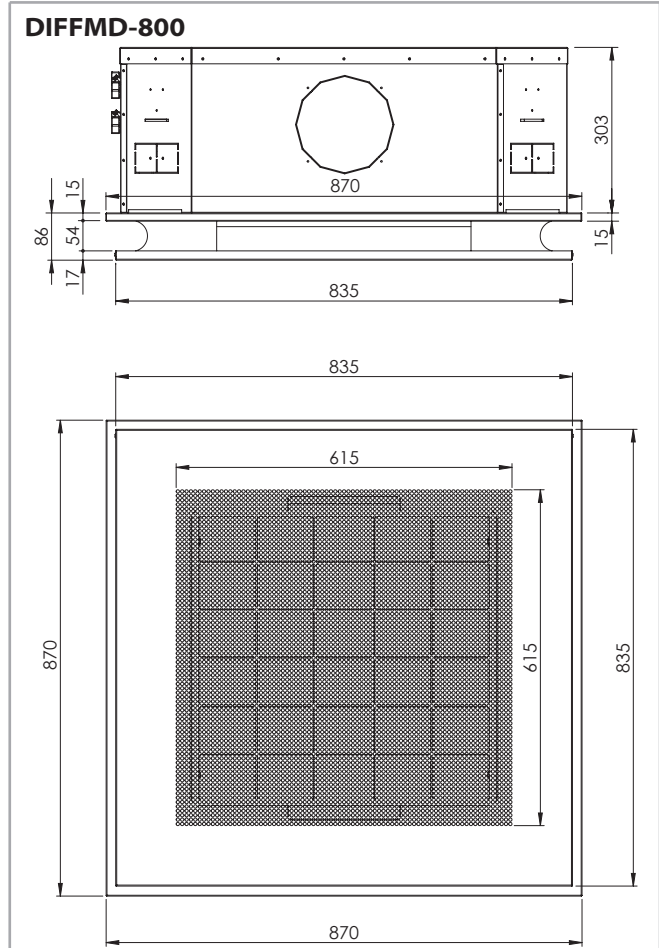
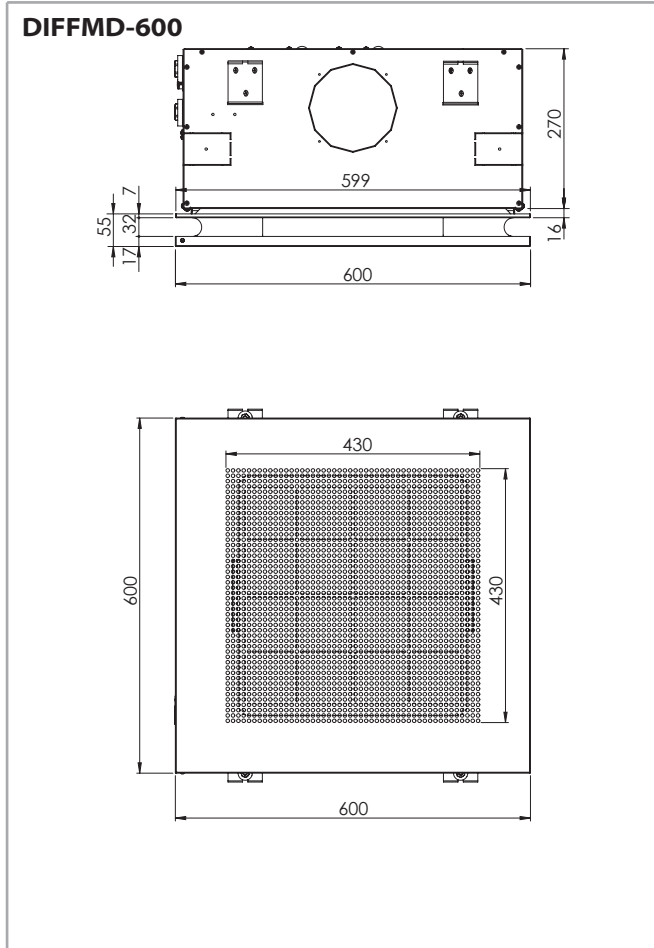

AIR THROW

The air throw indicated in the tables must only be considered the maximum value, as it may change significantly in relation to the dimensions of the room in which the appliance is installed and the positioning of the furniture in the room.

The useful throw L refers to the distance between the unit and the point where the air speed is 0.2 m/sec; if the louver has a gradient of 30° (recommended in cooling mode), the so-called "coanda" effect will occur,

illustrated in the first figure, while at a gradient of 45° (recommended in heating mode), there will be a downwards throw, as illustrated in the second figure.

Note: on heating it must be paid attention to rooms where the floor temperature is particularly low (for example less than 5 °C). In this situation the floor can cool the lower layer of air to a level that stops the uniform diffusion of the hot air coming from the unit, decreasing the throw figures shown in the table.

With adjustable air diffusion louvers at 30°

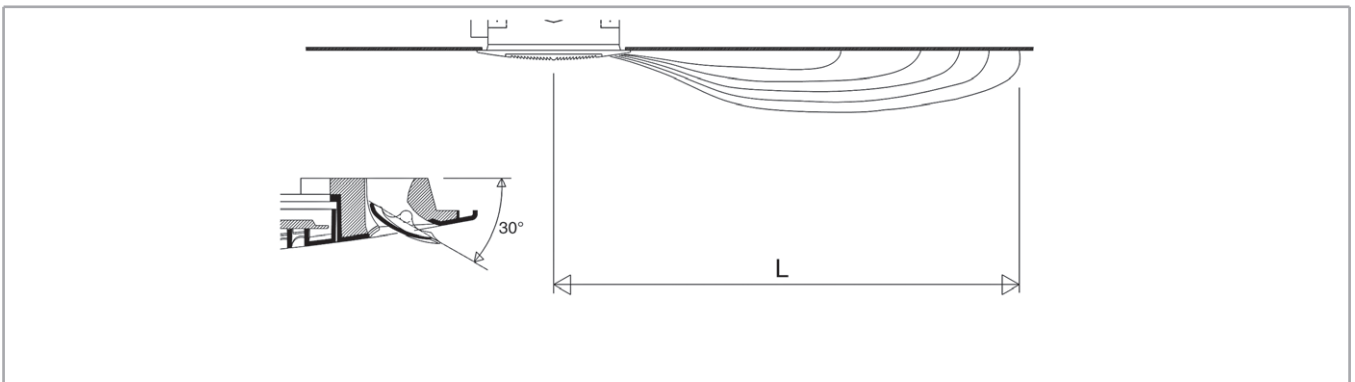

Model	02-2P - 04-4P - 12-2P - 14-4P			22-2P - 24-4P - 26-4P			32-2P - 34-4P - 36-4P			42-2P - 44-4P			52-2P - 54-4P - 56-4P			62-2P - 64-4P - 66-4P			
Speed	Min	Med	Max	Min	Med	Max	Min	Med	Max	Min	Med	Max	Min	Med	Max	Min	Med	Max	
L	m	3,0	3,5	3,8	3,0	3,8	4,5	3,5	4,2	5,0	3,2	3,7	4,3	3,4	4,0	5,0	3,4	4,6	5,5

With adjustable air diffusion louvers at 45°

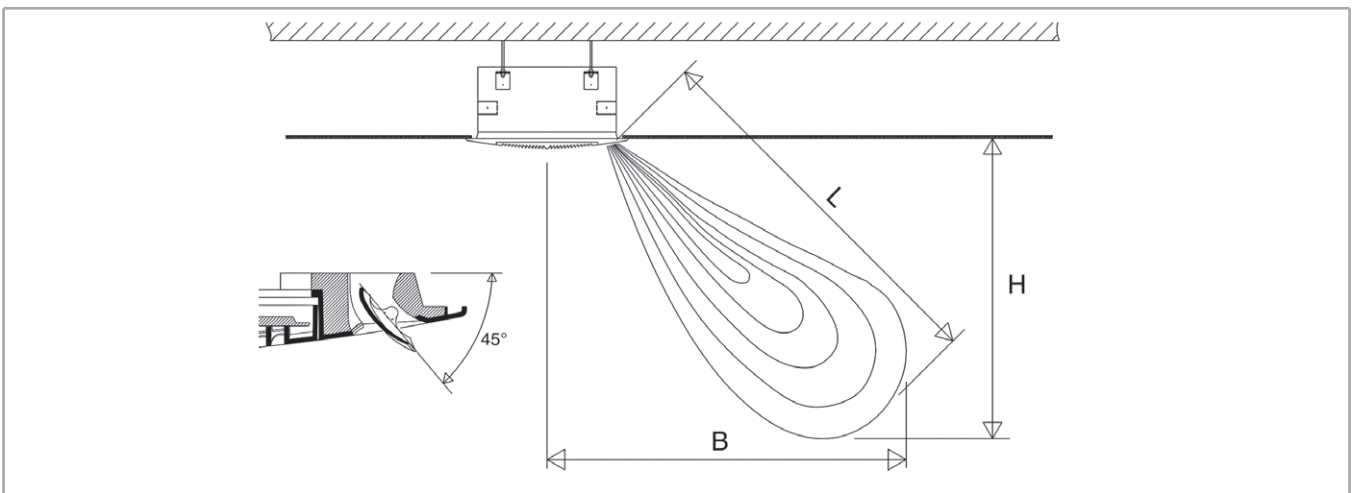

Model	02-2P - 04-4P - 12-2P - 14-4P			22-2P - 24-4P - 26-4P			32-2P - 34-4P - 36-4P			42-2P - 44-4P			52-2P - 54-4P - 56-4P			62-2P - 64-4P - 66-4P			
Speed	Min	Med	Max	Min	Med	Max	Min	Med	Max	Min	Med	Max	Min	Med	Max	Min	Med	Max	
L	m	3,3	3,9	4,2	3,3	4,2	4,8	3,9	4,5	5,2	3,5	4,1	4,8	3,8	4,6	5,4	3,8	5,1	5,8
H	m	2,2	2,6	2,8	2,2	2,8	3,2	2,6	3,0	3,4	2,2	2,6	3,0	2,4	2,8	3,4	2,4	3,1	3,6
B	m	2,5	2,9	3,1	2,5	3,1	3,6	2,9	3,4	3,9	2,7	3,2	3,8	3,0	3,6	4,2	3,0	4,0	4,6

CWS CONTROLS

All the units of the **CWS** range can be supplied with a wide range of controls that allows managing one single unit or several units (with the use of speed switches or with the use of the power units).

The options range from the basic **M-3V**, for 3 speed control only, to the highly sophisticated electronic room thermostats **T-TMO**, **T-REM** and **M-2T**, that regulate the room temperature and are suitable when the user wants to set the fan speed.

The most evolved versions **T-AUTO** and **IR-MB**, allow both the manual and the automatic speed switch.

M-3V control



230 V 50 Hz

T-TMO control



230 V 50-60 Hz

T-REM control



230 V 50-60 Hz

T-AUTO control (*)



230 V 50-60 Hz

IR-MB control (*)



230 V 50-60 Hz

M-2T control



230 V 50-60 Hz

(*) To be used with T-POWER-M or T-POWER-A only

Control systems

See from p. 49 for:

- the MB electronic board (to be fitted on the MB version)
- the MB controls and units

CWS-EH VERSION

The 2 pipe model Cassette units are available with electric heater.

The electric heater is controlled in place of the hot water valve and not as integration to it.

The electric heaters are hermetically sealed and supplied inside the coil pipes and therefore can be only factory mounted.

The electric resistances of the units are for single phase

230V supply.

The Cassette fan coil unit includes no. 2 safety thermostats which intervene in case of internal over-heating, opening an auxiliary power relay (included in the electrical panel) which stops the power supply to the electric heaters.

Note: the cooling emission of the units is 95% of the emission in the tables of p. 8.

Constructional features of the electric heater

Model		CWS 0-2P	CWS 1-2P	CWS 2-2P CWS 3-2P	CWS 4-2P CWS 5-2P CWS 6-2P
Emission	W	750	1500	2500	3000
Single-phase rated operating voltage	Vac/Ph/Hz	230/1/50			
Connecting wires	n x mm ²	3 x 1	3 x 1,5	3 x 2,5	
Maximum current absorbed	A	3,5	7	11	13,5
Advised fuse ⁽¹⁾	A	4	8	12	16
Max. ambient temperature ⁽²⁾	°C	25			

⁽¹⁾ = for the overheat protection; gG type

⁽²⁾ = with electric heater in heating mode

CWS-EH CONTROLS

T-TMO control



230 V 50-60 Hz

T-AUTO control (*)



230 V 50-60 Hz

T-REM control



230 V 50-60 Hz

IR-MB control (*)



230 V 50-60 Hz

(*) To be used with T-POWER-M or T-POWER-A only

AIR DIFFUSER - DIFF

Version

White ABS, RAL 9003.

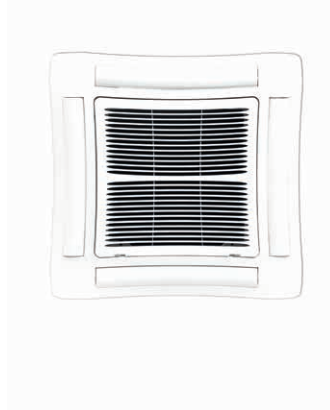

Version

In ABS painted in one color to choose.



MAIN COMPONENTS

600 x 600 version



800 x 800 version



Air diffuser

Intake grids, frame and adjustable air distribution louvers on each side, made from ABS.

- DIFF version white ABS, RAL 9003.
- DIFF version with intake grid, frame and louvers, choice of one colour only.
- DIFFMD-600 / DIFFMD-800 version: metal diffuser painted in RAL 9003 white colour with 600x600 / 800x800 dimension to perfectly fit into the false ceiling standard modules without overlapping parts.

Inner casing

It is made of galvanized steel with internal thermal insulation with polyolefin (PO) foam (class M1) and external anti-condensate lining.

Control panel

- **CWE** version

It consists of the pump control circuit board and the inverter circuit board.

- **CWE-MB** version

It consists of the MB electronic board (that integrates pump control) and the inverter board.

Fan assembly

The fan assembly, which is mounted on anti-vibrating supports, is extremely silent.

The radial fan has been designed to optimise performance, using wing profile blades with a shape that reduces turbulence, increasing efficiency and reducing noise.

The fans are connected to a three phase permanent magnet brushless electronic motor that is controlled with reconstructed current according to a BLAC sinusoidal wave.

The inverter board that controls the motor operation is powered by 230 Volt, single-phase and, with a switching system, it generates a three-phase frequency modulated, wave form power supply.

The power supply of the unit is single phase 230-240Vac 50/60Hz.

Coil

Made of copper tubes with bonded aluminium fins for maximum transfer contact.

2 or 3 row coil for 2 pipe models and 2+1 row coil for 4 pipe models (the heating row is on the inside part of the coil).

For 4 pipe systems two versions are available: the CWE 1-4P e CWE 4-4P serie supply an higher heating emission; and the CWS 2-4P, CWS 3-4P, CWS 5-4P serie supply an higher cooling emission.

The heat exchanger is not suitable for use in corrosive atmosphere or in environments where aluminium may be subject to corrosion.

Condensate collection tray

High density ABS polystyrene foam condensate tray, shaped in order to optimize the air diffusion.

Fire retardant rating B1 to DIN 4102.

Filter

Synthetic washable filter, easily removable.

Condensate pump

Float switch centrifugal pump with 650 mm of maximum head, integral to the unit and wired to the control panel on the outside of the casing.

Valve set

Two or three way valves for ON/OFF operation, with pipe mounting kit and lockshields.



EUROVENT CERTIFICATIONS

2 pipe system

The following standard rating conditions are used:

COOLING

Entering air temperature: + 27 °C d.b. + 19 °C w.b.
Water temperature: +7 °C E.W.T. +12 °C L.W.T.

HEATING

Entering air temperature: + 20 °C
Water temperature: +45 °C E.W.T. +40 °C L.W.T.

MODEL	Inverter power	CWE 1-2P					CWE 2-2P					CWE 3-2P				
		1 MIN	3	5 MED	7,5	10 MAX	1 MIN	3	5 MED	7,5	10 MAX	1 MIN	3	5 MED	7,5	10 MAX
Air flow	m³/h	310	345	380	457	535	310	377	445	577	710	360	485	610	745	880
Cooling total emission (E)	kW	1,84	2,01	2,16	2,47	2,73	2,24	2,65	3,04	3,71	4,30	2,55	3,25	3,85	4,45	4,96
Cooling sensible emission (E)	kW	1,35	1,47	1,60	1,84	2,07	1,57	1,87	2,16	2,67	3,15	1,80	2,31	2,79	3,25	3,68
Heating emission (E)	kW	1,85	2,04	2,22	2,55	2,87	2,12	2,56	2,98	3,68	4,36	2,46	3,17	3,85	4,52	5,15
Dp Cooling (E)	kPa	4,9	5,8	6,6	8,4	10,1	4,6	6,3	9,4	11,6	15,1	5,9	9,1	12,4	16,2	19,7
Dp Heating (E)	kPa	4,3	5,1	5,9	7,6	9,4	3,6	5,1	6,6	9,7	13,2	4,7	7,5	10,6	14,1	17,8
Sound power (Lw) (E)	dB(A)	33,0	36,0	39,0	43,0	47,0	33,0	38,0	43,0	48,5	54,0	37,0	43,5	50,0	55,0	60,0
Sound pressure (Lp) ⁽¹⁾	dB(A)	24,0	27,0	30,0	34,0	38,0	24,0	29,0	34,0	39,5	45,0	28,0	34,5	41,0	46,0	51,0
Motor power input (E)	W	5,0	6,5	8,0	12,0	16,0	5,0	8,0	11,0	21,0	31,0	7,0	14,0	21,0	41,5	62,0
Condensate drain pump power absorption	W	10	10	10	10	10	10	10	10	10	10	10	10	10	10	10
Water content	l	1,4	1,4	1,4	1,4	1,4	2,1	2,1	2,1	2,1	2,1	2,1	2,1	2,1	2,1	2,1
Length	mm	575	575	575	575	575	575	575	575	575	575	575	575	575	575	575
Depth	mm	575	575	575	575	575	575	575	575	575	575	575	575	575	575	575
Height	mm	275	275	275	275	275	275	275	275	275	275	275	275	275	275	275

MODEL	Inverter power	CWE 4-2P					CWE 5-2P				
		1 MIN	3	5 MED	7,5	10 MAX	1 MIN	3	5 MED	7,5	10 MAX
Air flow	m³/h	630	750	870	1017	1165	710	920	1130	1450	1770
Cooling total emission (E)	kW	4,20	4,70	5,13	5,76	6,30	5,28	6,54	7,69	9,28	10,69
Cooling sensible emission (E)	kW	3,02	3,39	3,75	4,23	4,69	3,68	4,62	5,50	6,71	7,83
Heating emission (E)	kW	4,27	4,78	5,30	6,02	6,70	4,90	6,18	7,34	9,00	10,56
Dp Cooling (E)	kPa	10,9	13,3	15,6	19,3	22,7	9,4	13,8	18,5	26,1	33,0
Dp Heating (E)	kPa	9,6	11,8	14,2	17,9	21,6	7,0	10,7	14,6	21,1	28,1
Sound power (Lw) (E)	dB(A)	33,0	36,0	39,0	43,5	48,0	34,0	40,5	47,0	52,0	57,0
Sound pressure (Lp) ⁽¹⁾	dB(A)	24,0	27,0	30,0	34,5	39,0	25,0	31,5	38,0	43,0	48,0
Motor power input (E)	W	10,0	13,5	17,0	25,0	33,0	10,0	21,0	32,0	70,0	108,0
Condensate drain pump power absorption	W	10	10	10	10	10	10	10	10	10	10
Water content	l	3,0	3,0	3,0	3,0	3,0	4,0	4,0	4,0	4,0	4,0
Length	mm	820	820	820	820	820	820	820	820	820	820
Depth	mm	820	820	820	820	820	820	820	820	820	820
Height	mm	303	303	303	303	303	303	303	303	303	303

(E) Eurovent certified performance (MIN-MED-MAX speed)

(1) The sound pressure levels are 9 dB (A) lower than the sound power levels, apply to the reverberant field of a 100 m³ room and a reverberation time of 0.5 sec.



4 pipe system

The following standard rating conditions are used:

COOLING

Entering air temperature: + 27 °C d.b. + 19 °C w.b.
Water temperature: +7 °C E.W.T. +12 °C L.W.T.

HEATING

Entering air temperature: + 20 °C
Water temperature: +65 °C E.W.T. +55 °C L.W.T.

MODEL	Inverter power	CWE 1-4P					CWE 2-4P					CWE 3-4P				
		1 MIN	3	5 MED	7,5	10 MAX	1 MIN	3	5 MED	7,5	10 MAX	1 MIN	3	5 MED	7,5	10 MAX
Air flow	m ³ /h	310	345	380	457	535	310	377	445	577	710	360	485	610	745	880
Cooling total emission (E)	kW	1,85	2,02	2,17	2,48	2,75	2,09	2,46	2,81	3,39	3,90	2,37	2,99	3,51	4,03	4,47
Cooling sensible emission (E)	kW	1,34	1,31	1,59	1,64	2,06	1,49	1,76	2,03	2,49	2,92	1,70	2,17	2,60	3,01	3,40
Heating emission (E)	kW	2,13	2,32	2,51	2,85	3,18	1,73	1,97	2,20	2,57	2,91	1,92	2,31	2,66	2,99	3,29
Dp Cooling (E)	kPa	4,6	5,4	6,2	7,9	9,5	3,3	4,4	5,6	7,9	10,3	4,1	6,3	8,4	10,9	13,1
Dp Heating (E)	kPa	4,6	5,3	6,1	7,7	9,4	2,6	3,3	4,1	5,4	6,7	3,2	4,4	5,7	7,1	8,4
Sound power (Lw) (E)	dB(A)	33,0	36,0	39,0	43,0	47,0	33,0	38,0	43,0	48,5	54,0	37,0	43,5	50,0	55,0	60,0
Sound pressure (Lp) ⁽¹⁾	dB(A)	24,0	27,0	30,0	34,0	38,0	24,0	29,0	34,0	39,5	45,0	28,0	34,5	41,0	46,0	51,0
Motor power input (E)	W	5,0	6,5	8,0	12,0	16,0	5,0	8,0	11,0	21,0	31,0	7,0	14,0	21,0	41,5	62,0
Condensate drain pump power absorption	W	10	10	10	10	10	10	10	10	10	10	10	10	10	10	10
Cooling water content	l	1,4	1,4	1,4	1,4	1,4	1,7	1,7	1,7	1,7	1,7	1,7	1,7	1,7	1,7	1,7
Heating water content	l	0,7	0,7	0,7	0,7	0,7	0,5	0,5	0,5	0,5	0,5	0,5	0,5	0,5	0,5	0,5
Length	mm	575	575	575	575	575	575	575	575	575	575	575	575	575	575	575
Depth	mm	575	575	575	575	575	575	575	575	575	575	575	575	575	575	575
Height	mm	275	275	275	275	275	275	275	275	275	275	275	275	275	275	275

MODEL	Inverter power	CWE 4-4P					CWE 5-4P				
		1 MIN	3	5 MED	7,5	10 MAX	1 MIN	3	5 MED	7,5	10 MAX
Air flow	m ³ /h	630	750	870	1017	1165	710	920	1130	1450	1770
Cooling total emission (E)	kW	4,29	4,81	5,29	5,92	6,48	4,97	6,13	7,14	8,56	9,76
Cooling sensible emission (E)	kW	3,07	3,46	3,82	4,32	4,80	3,51	4,37	5,17	6,27	7,29
Heating emission (E)	kW	5,41	6,04	6,65	7,46	8,24	4,58	5,47	6,27	7,36	8,33
Dp Cooling (E)	kPa	9,4	11,6	13,6	16,8	19,8	8,8	12,9	17,0	23,7	30,1
Dp Heating (E)	kPa	8,5	10,3	12,3	15,1	18,1	4,9	6,7	8,6	11,4	14,3
Sound power (Lw) (E)	dB(A)	33,0	36,0	39,0	43,5	48,0	34,0	40,5	47,0	52,0	57,0
Sound pressure (Lp) ⁽¹⁾	dB(A)	24,0	27,0	30,0	34,5	39,0	25,0	31,5	38,0	43,0	48,0
Motor power input (E)	W	10,0	13,5	17,0	25,0	33,0	10,0	21,0	32,0	70,0	108,0
Condensate drain pump power absorption	W	10	10	10	10	10	10	10	10	10	10
Cooling water content	l	3,0	3,0	3,0	3,0	3,0	3,6	3,6	3,6	3,6	3,6
Heating water content	l	1,4	1,4	1,4	1,4	1,4	1,1	1,1	1,1	1,1	1,1
Length	mm	820	820	820	820	820	820	820	820	820	820
Depth	mm	820	820	820	820	820	820	820	820	820	820
Height	mm	303	303	303	303	303	303	303	303	303	303

(E) Eurovent certified performance (MIN-MED-MAX speed)

(1) The sound pressure levels are 9 dB (A) lower than the sound power levels, apply to the reverberant field of a 100 m³ room and a reverberation time of 0.5 sec.

COOLING EMISSION

Models with single coil (2 pipe installations)

Entering air temperature: 27 °C – R.H.: 50%

Model	Vdc	WT: 7 / 12 °C			WT: 8 / 13 °C			WT: 10 / 15 °C			WT: 12 / 17 °C			
		Qv m ³ /h	Pc kW	Ps kW	Qw l/h	Pc kW	Ps kW	Qw l/h	Pc kW	Ps kW	Qw l/h	Pc kW	Ps kW	Qw l/h
CWE 1-2P	10	535	2,94	2,06	506	2,64	1,94	455	1,78	1,78	307	1,53	1,53	263
	7,5	457	2,64	1,84	455	2,38	1,73	409	1,88	1,52	323	1,36	1,36	234
	5	380	2,32	1,60	399	2,09	1,50	360	1,65	1,32	284	1,20	1,20	206
	3	345	2,15	1,47	370	1,94	1,38	334	1,54	1,22	264	1,10	1,10	190
	1	310	1,97	1,34	339	1,78	1,26	307	1,41	1,11	242	1,00	1,00	173
CWE 2-2P	10	710	4,61	3,14	792	4,16	2,95	716	3,29	2,60	566	2,35	2,35	404
	7,5	577	3,96	2,67	681	3,59	2,51	617	2,85	2,20	490	2,20	1,93	379
	5	445	3,25	2,16	559	2,95	2,03	508	2,35	1,78	403	1,81	1,56	312
	3	377	2,83	1,87	487	2,57	1,76	442	2,06	1,54	354	1,59	1,35	274
	1	310	2,39	1,56	410	2,17	1,47	373	1,75	1,29	300	1,35	1,13	232
CWE 3-2P	10	880	5,32	3,67	916	4,80	3,45	825	3,80	3,04	653	2,74	2,74	471
	7,5	745	4,75	3,24	817	4,29	3,05	738	3,40	2,69	585	2,43	2,43	417
	5	610	4,13	2,79	710	3,74	2,62	643	2,97	2,31	510	2,29	2,02	394
	3	485	3,46	2,31	596	3,14	2,17	541	2,49	1,91	429	1,93	1,67	332
	1	360	2,73	1,80	470	2,48	1,69	426	1,99	1,49	342	1,54	1,30	264
CWE 4-2P	10	1165	6,76	4,67	1162	6,10	4,40	1049	4,80	3,88	826	3,48	3,48	599
	7,5	1017	6,15	4,22	1057	5,55	3,97	955	4,39	3,49	755	3,14	3,14	541
	5	870	5,50	3,74	945	4,97	3,52	856	3,93	3,10	675	2,79	2,79	480
	3	750	5,01	3,39	861	4,54	3,19	780	3,60	2,80	619	2,55	2,55	438
	1	630	4,49	3,02	772	4,07	2,84	426	3,23	2,49	556	2,50	2,18	430
CWE 5-2P	10	1770	11,41	7,81	1962	10,30	7,35	1772	8,20	6,48	1410	5,89	5,89	1012
	7,5	1450	9,90	6,70	1702	8,96	6,29	1541	7,14	5,55	1227	5,53	4,87	951
	5	1130	8,22	5,49	1415	7,45	5,17	1281	5,96	4,54	1026	4,60	3,98	791
	3	920	6,98	4,61	1200	6,34	4,34	1090	5,09	3,81	875	3,92	3,33	675
	1	710	5,63	3,68	968	5,12	3,46	881	4,13	3,04	710	3,20	2,66	550

WT: Water temperature
Vdc: Inverter power
Qv: Air flow
Pc: Cooling total emission
Ps: Cooling sensible emission
Qw: Water flow rate

Models with double coil (4 pipe installations)

Entering air temperature: 27 °C – R.H.: 50%

Model	Vdc	WT: 7 / 12 °C			WT: 8 / 13 °C			WT: 10 / 15 °C			WT: 12 / 17 °C			
		Qv m³/h	Pc kW	Ps kW	Qw l/h	Pc kW	Ps kW	Qw l/h	Pc kW	Ps kW	Qw l/h	Pc kW	Ps kW	Qw l/h
CWE 1-4P	10	535	2,95	2,05	508	2,66	1,93	458	1,77	1,77	305	1,52	1,52	261
	7,5	457	2,65	1,83	456	2,39	1,72	412	1,89	1,52	325	1,37	1,37	235
	5	380	2,33	1,59	401	2,10	1,50	362	1,66	1,32	286	1,19	1,19	204
	3	345	2,16	1,47	371	1,95	1,38	336	1,54	1,21	265	1,09	1,09	188
	1	310	1,98	1,33	340	1,79	1,26	308	1,41	1,10	242	0,99	0,99	171
CWE 2-4P	10	710	4,19	2,91	720	3,77	2,73	648	2,98	2,41	513	2,16	2,16	372
	7,5	577	3,62	2,49	623	3,27	2,34	562	2,59	2,06	446	1,85	1,85	319
	5	445	3,00	2,03	516	2,71	1,91	467	2,15	1,68	369	1,52	1,52	261
	3	377	2,63	1,76	452	2,38	1,66	409	1,90	1,46	326	1,46	1,28	251
	1	310	2,23	1,48	383	2,02	1,39	347	1,61	1,22	277	1,24	1,07	214
CWE 3-4P	10	880	4,80	3,38	826	4,31	3,18	742	3,41	2,81	586	2,51	2,51	431
	7,5	745	4,31	3,00	742	3,88	2,82	667	3,06	2,49	527	2,23	2,23	384
	5	610	3,77	2,60	649	3,40	2,44	585	2,69	2,15	462	1,94	1,94	333
	3	485	3,19	2,17	548	2,88	2,04	496	2,28	1,79	393	1,62	1,62	278
	1	360	2,54	1,70	436	2,30	1,60	395	1,83	1,40	314	1,41	1,23	243
CWE 4-4P	10	1165	6,95	4,79	1196	6,28	4,50	1080	4,95	3,96	851	3,56	3,56	613
	7,5	1017	6,31	4,31	1086	5,71	4,06	982	4,51	3,57	775	3,21	3,21	553
	5	870	5,64	3,82	969	5,10	3,59	878	4,05	3,16	697	2,88	2,88	495
	3	750	5,13	3,45	882	4,65	3,25	800	3,69	2,86	634	2,60	2,60	447
	1	630	4,59	3,07	790	4,17	2,89	717	3,30	2,54	567	2,55	2,22	439
CWE 5-4P	10	1770	10,47	7,26	1801	9,44	6,83	1623	7,48	6,03	1286	5,42	5,42	933
	7,5	1450	9,14	6,25	1571	8,25	5,88	1419	6,53	5,18	1123	4,68	4,68	805
	5	1130	7,65	5,17	1315	6,93	4,86	1191	5,48	4,27	942	4,25	3,74	731
	3	920	6,53	4,36	1123	5,93	4,10	1019	4,71	3,60	810	3,63	3,16	625
	1	710	5,31	3,51	913	4,83	3,30	831	3,86	2,90	664	2,99	2,53	514

WT: Water temperature
Vdc: Inverter power
Qv: Air flow
Pc: Cooling total emission
Ps: Cooling sensible emission
Qw: Water flow rate

HEATING EMISSION

Models with single coil (2 pipe installations)

Entering air temperature: +20 °C

Model	Vdc	Qv m ³ /h	WT: 70 / 60 °C		WT: 60 / 50 °C		WT: 55 / 45 °C		WT: 50 / 40 °C		WT: 45 / 40 °C	
			Ph kW	Qw l/h	Ph kW	Qw l/h	Ph kW	Qw l/h	Ph kW	Qw l/h	Ph kW	Qw l/h
CWE 1-2P	10	535	5,82	500	4,49	387	3,83	330	3,17	272	2,87	247
	7,5	457	5,16	444	3,99	343	3,41	293	2,82	243	2,55	219
	5	380	4,51	387	3,49	300	2,99	257	2,48	213	2,22	191
	3	345	4,13	355	3,21	276	2,74	236	2,28	196	2,04	176
	1	310	3,75	322	2,91	250	2,49	214	2,07	178	1,85	159
CWE 2-2P	10	710	8,81	758	6,85	589	5,87	505	4,89	420	4,36	375
	7,5	577	7,44	640	5,80	499	4,97	428	4,15	357	3,68	317
	5	445	6,01	517	4,70	404	4,04	347	3,38	290	2,98	256
	3	377	5,16	444	4,05	348	3,48	300	2,92	251	2,56	220
	1	310	4,28	368	3,36	289	2,90	249	2,43	209	2,12	183
CWE 3-2P	10	880	10,42	896	8,09	696	6,92	595	5,75	494	5,15	443
	7,5	745	9,14	786	7,11	611	6,09	524	5,06	435	4,52	389
	5	610	7,79	670	6,07	522	5,20	448	4,34	373	3,85	331
	3	485	6,41	551	5,01	430	4,30	370	3,59	309	3,17	273
	1	360	4,96	427	3,89	335	3,35	288	2,81	241	2,46	212
CWE 4-2P	10	1165	13,54	1165	10,51	904	9,00	774	7,47	642	6,70	576
	7,5	1017	12,16	1046	9,46	813	8,10	696	6,73	579	6,02	517
	5	870	10,72	922	8,34	717	7,15	615	5,95	512	5,30	456
	3	750	9,65	830	7,52	647	6,45	555	5,38	463	4,78	411
	1	630	8,61	741	6,72	578	5,78	497	4,82	415	4,27	367
CWE 5-2P	10	1770	21,37	1837	16,60	1428	14,21	1222	11,81	1015	10,56	908
	7,5	1450	18,20	1565	14,17	1219	12,15	1045	10,11	870	9,00	774
	5	1130	14,82	1274	11,56	994	9,93	854	8,29	713	7,34	631
	3	920	12,47	1073	9,76	839	8,40	722	7,02	604	6,18	532
	1	710	9,87	849	7,74	666	6,67	574	5,60	481	4,90	421

WT: Water temperature
Vdc: Inverter power
Qv: Air flow
Ph: Heating emission
Qw: Water flow rate

Models with double coil (4 pipe installations)

Entering air temperature: +20 °C

Model	Vdc	Qv m³/h	WT: 70 / 60 °C		WT: 60 / 50 °C		WT: 55 / 45 °C		WT: 50 / 40 °C		WT: 45 / 40 °C	
			Ph kW	Qw l/h	Ph kW	Qw l/h	Ph kW	Qw l/h	Ph kW	Qw l/h	Ph kW	Qw l/h
CWE 1-4P	10	535	3,62	311	2,74	236	2,30	198	1,87	161	1,78	153
	7,5	457	3,24	279	2,46	212	2,07	178	1,68	144	1,59	137
	5	380	2,85	245	2,16	186	1,82	156	1,48	127	1,40	120
	3	345	2,64	227	2,01	172	1,69	145	1,37	118	1,30	112
	1	310	2,43	209	1,84	158	1,55	133	1,26	108	1,19	103
CWE 2-4P	10	710	3,35	288	2,48	213	2,04	176	1,61	139	1,62	139
	7,5	577	2,96	254	2,19	189	1,81	156	1,43	123	1,43	123
	5	445	2,53	217	1,87	161	1,55	133	1,23	106	1,23	105
	3	377	2,27	195	1,68	145	1,39	120	1,11	95	1,10	95
	1	310	1,98	170	1,47	127	1,22	105	0,97	83	0,96	83
CWE 3-4P	10	880	3,79	326	2,80	241	2,31	198	1,82	156	1,83	158
	7,5	745	3,44	296	2,54	219	2,10	181	1,66	142	1,67	143
	5	610	3,06	263	2,27	195	1,87	161	1,48	127	1,48	127
	3	485	2,66	229	1,97	170	1,63	140	1,29	111	1,29	111
	1	360	2,20	189	1,64	141	1,36	117	1,08	93	1,07	92
CWE 4-4P	10	1165	9,36	805	7,13	613	6,01	517	4,90	421	4,61	396
	7,5	1017	8,48	729	6,46	555	5,45	468	4,44	382	4,17	359
	5	870	7,54	649	5,75	494	4,85	417	3,96	340	3,72	320
	3	750	6,86	590	5,23	450	4,41	380	3,60	310	3,38	291
	1	630	6,14	528	4,68	403	3,96	340	3,23	278	3,03	260
CWE 5-4P	10	1770	9,51	818	7,15	615	5,97	514	4,80	413	4,65	400
	7,5	1450	8,40	722	6,32	543	5,28	454	4,25	365	4,11	353
	5	1130	7,16	616	5,39	464	4,51	388	3,63	312	3,50	301
	3	920	6,24	537	4,70	405	3,94	339	3,18	273	3,06	263
	1	710	5,22	449	3,94	339	3,30	284	2,67	229	2,56	220

WT: Water temperature
Vdc: Inverter power
Qv: Air flow
Ph: Heating emission
Qw: Water flow rate

WATER SIDE PRESSURE DROP

2 pipe system

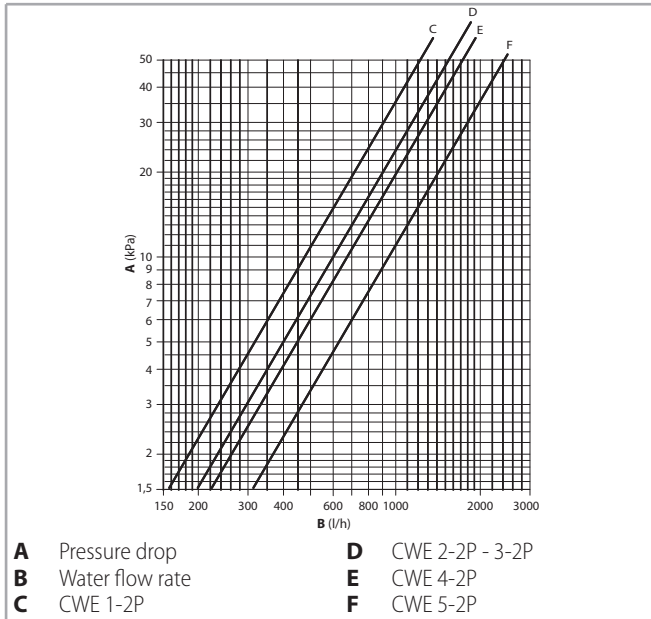

Pressure drop for mean water temperature of 10 °C, for different temperatures multiply the pressure drop figure by the K correction factors in the table.

K correction factor	Mean water temperature (°C)						
	20	30	40	50	60	70	80
	0,94	0,90	0,86	0,82	0,78	0,74	0,70

4 pipe system

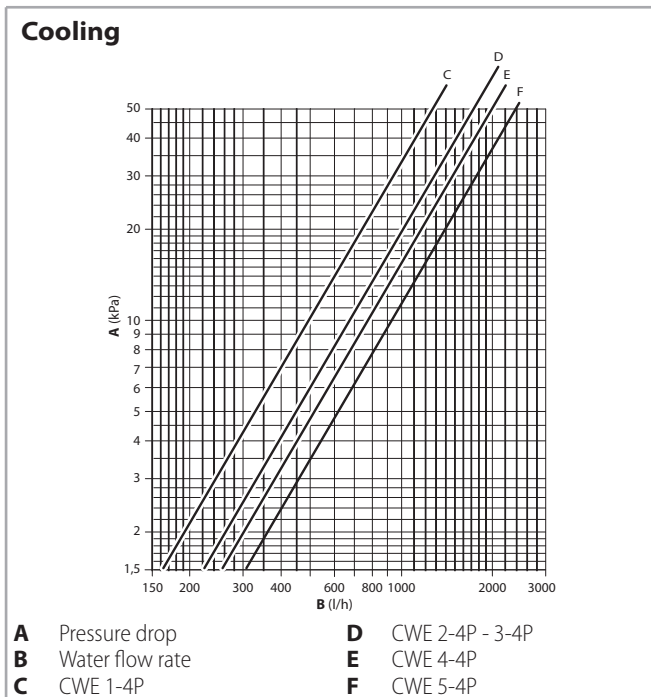

Pressure drop for mean water temperature of 10 °C, for different temperatures multiply the pressure drop figure by the K correction factors in the table.

K correction factor	Mean water temperature (°C)						
	20	30	40	50	60	70	80
	0,94	0,90	0,86	0,82	0,78	0,74	0,70

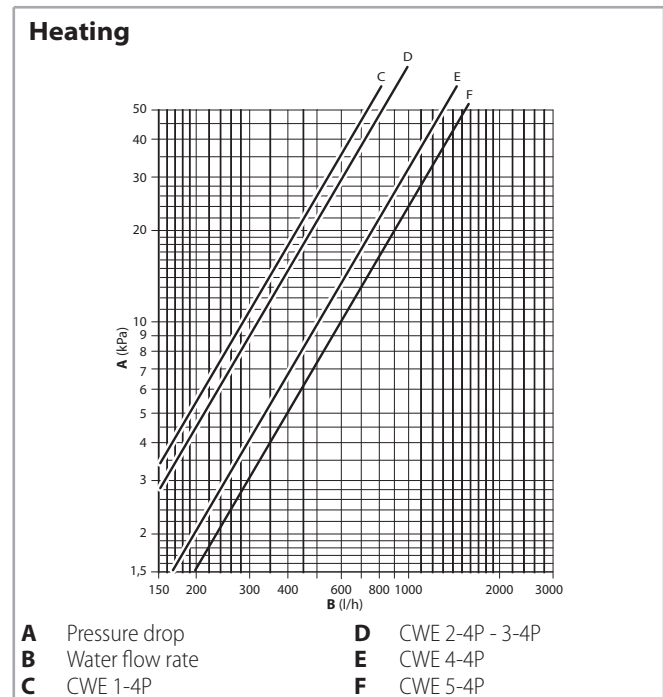

Pressure drop for mean water temperature of 60 °C, for different temperatures multiply the pressure drop figure by the K correction factors in the table.

K correction factor	Mean water temperature (°C)			
	40	50	70	80
	1,12	1,06	0,94	0,88

OPERATING LIMITS

Description		UoM	Value
Water flow	Highest working pressure	bars	10
		kPa	1000
	Lowest water inlet temperature	°C	+6
	Highest water inlet temperature	°C	+80
Power supply	Single-phase rated operating voltage	V/Hz	230/50

For maximum installation height, see p. 33.



DIMENSION AND WEIGHT

CWE 1 / 2 / 3 (600 x 600 version)

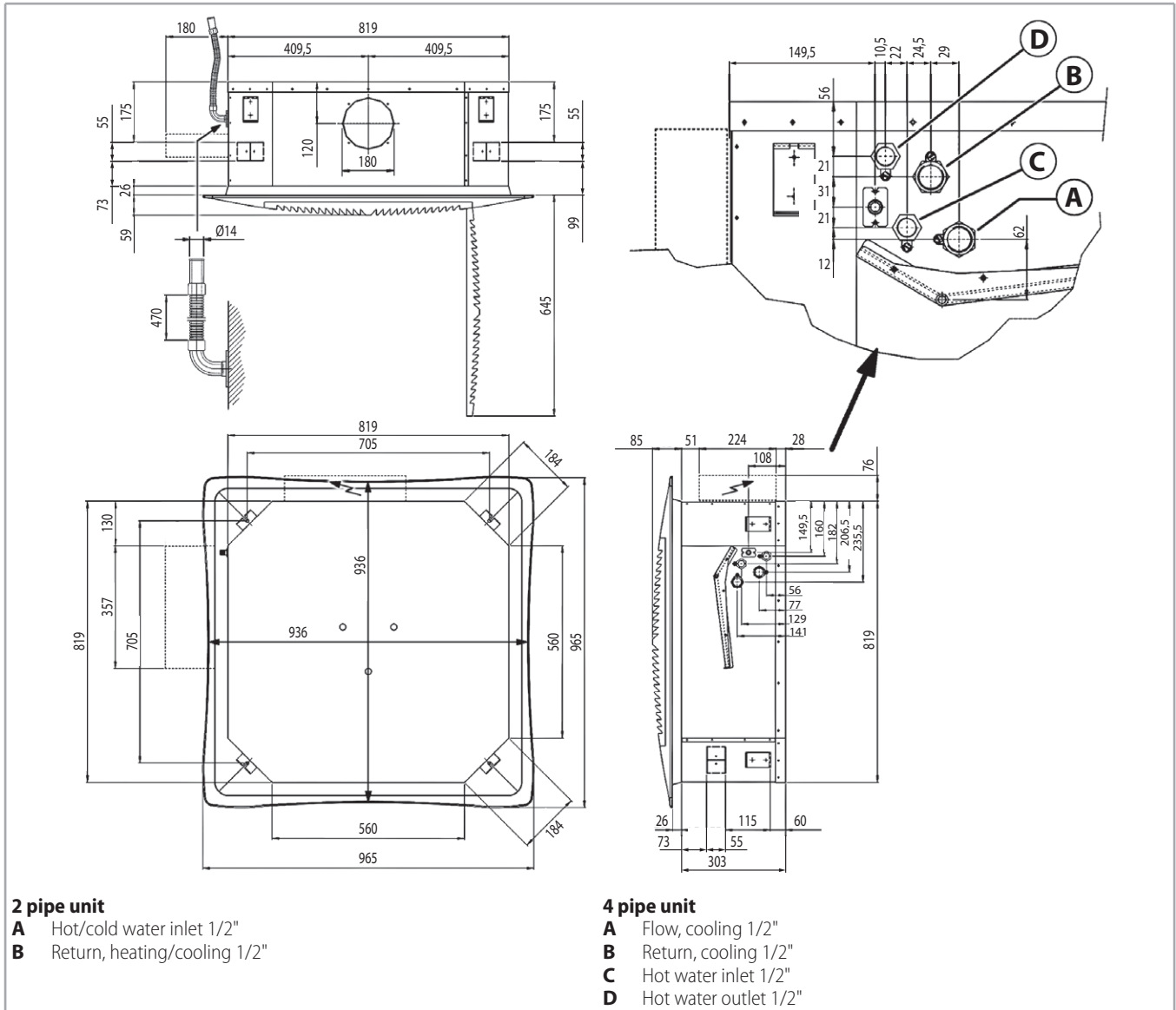

Packed unit

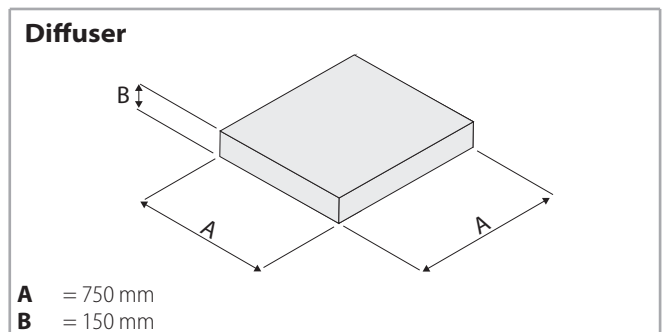
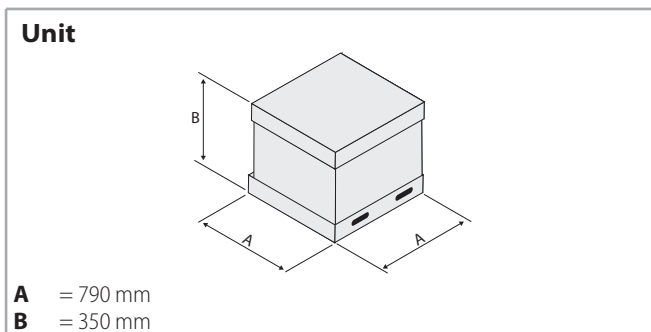

Weight/Model		1-2P	1-4P	2-2P - 2-4P	3-2P - 3-4P
With packaging	kg	28		30	
Without packaging	kg	22		24	

Weight/Model		1-2P	1-4P	2-2P - 2-4P	3-2P - 3-4P
With packaging	kg			6	
Without packaging	kg			3	

CWE 4 / 5 (800 x 800 version)

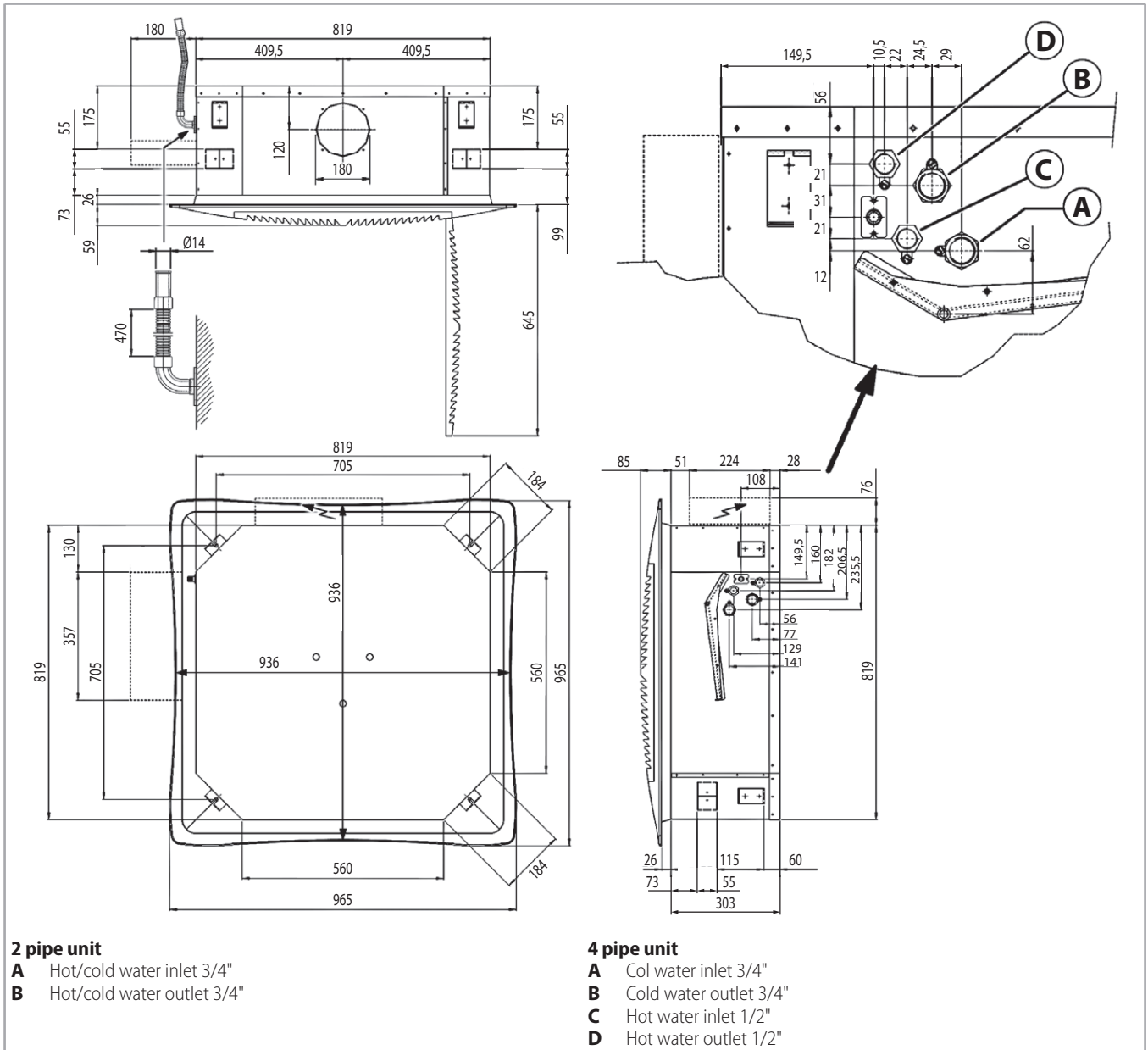

Packed unit

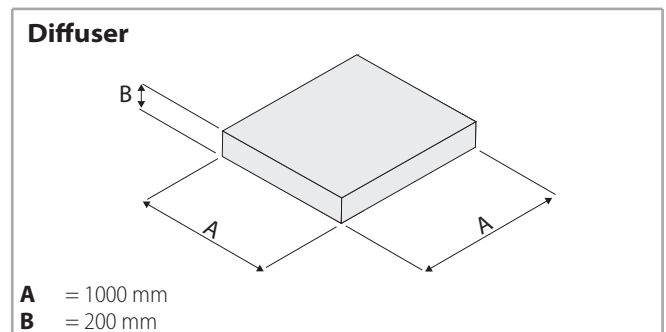
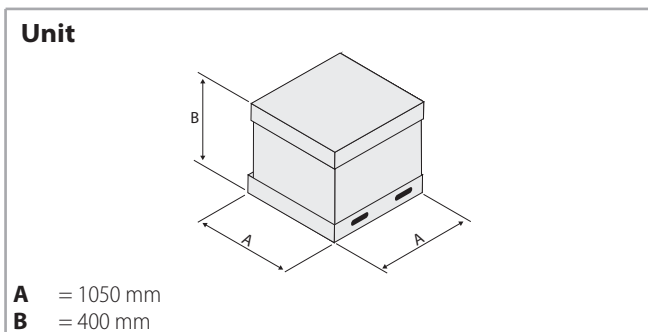

Weight/Model		4-2P	4-4P	5-2P - 5-4P
With packaging	kg	44		47
Without packaging	kg	36		39

Weight/Model		4-2P	4-4P	5-2P - 5-4P
With packaging	kg		10	
Without packaging	kg		6	

DIFFMD-600 / DIFFMD-800 metal air inlet grid

(REC-AD receiver, Code 9066338, for DIFFMD-600 / DIFFMD-800 metal diffuser for MB units)

Not suitable with electronic electrostatic filter.

Model	Code
DIFFMD-600	9079420
DIFFMD-800	9079417

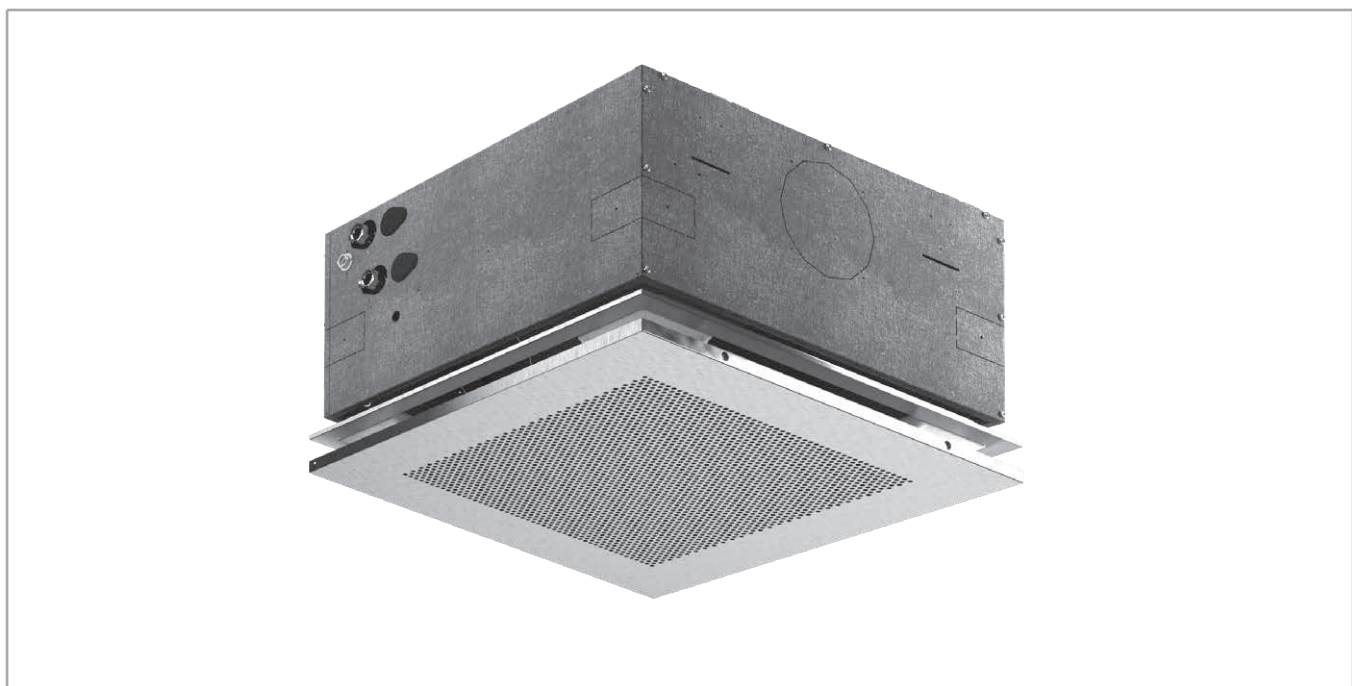
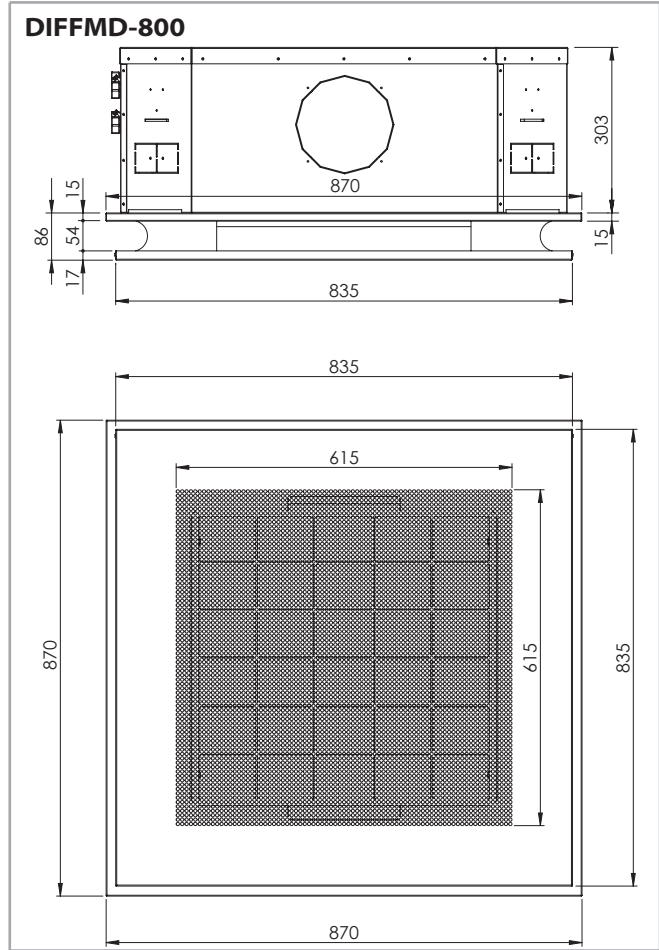
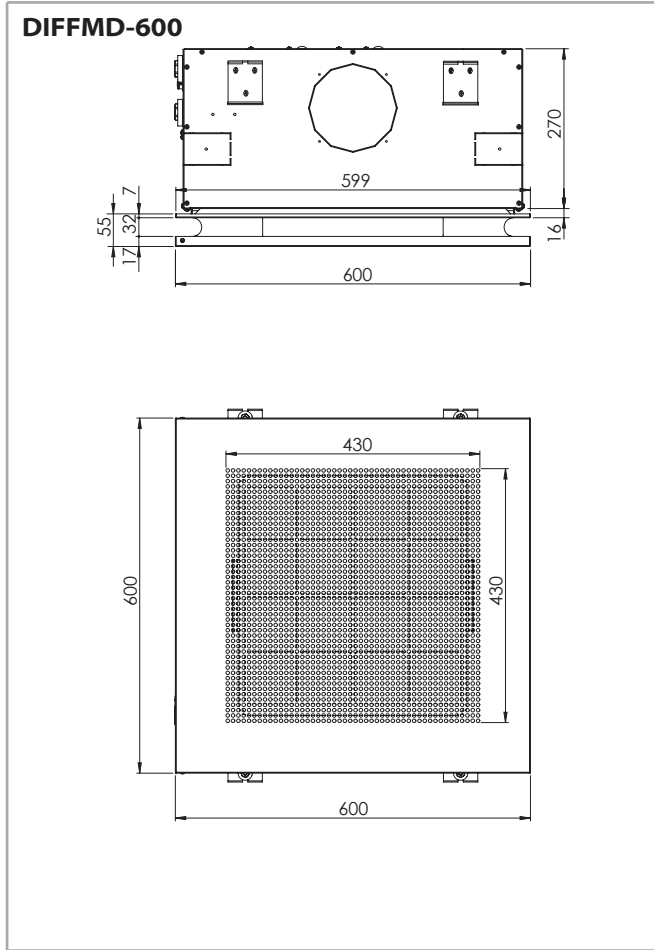

AIR THROW

The air throw indicated in the tables must only be considered the maximum value, as it may change significantly in relation to the dimensions of the room in which the appliance is installed and the positioning of the furniture in the room.

The useful throw L refers to the distance between the unit and the point where the air speed is 0.2 m/sec; if the louver has a gradient of 30° (recommended in cooling mode), the so-called "coanda" effect will occur,

illustrated in the first figure, while at a gradient of 45° (recommended in heating mode), there will be a downwards throw, as illustrated in the second figure.

Note: on heating it must be paid attention to rooms where the floor temperature is particularly low (for example less than 5°C). In this situation the floor can cool the lower layer of air to a level that stops the uniform diffusion of the hot air coming from the unit, decreasing the throw figures shown in the table.

With adjustable air diffusion louvers at 30°

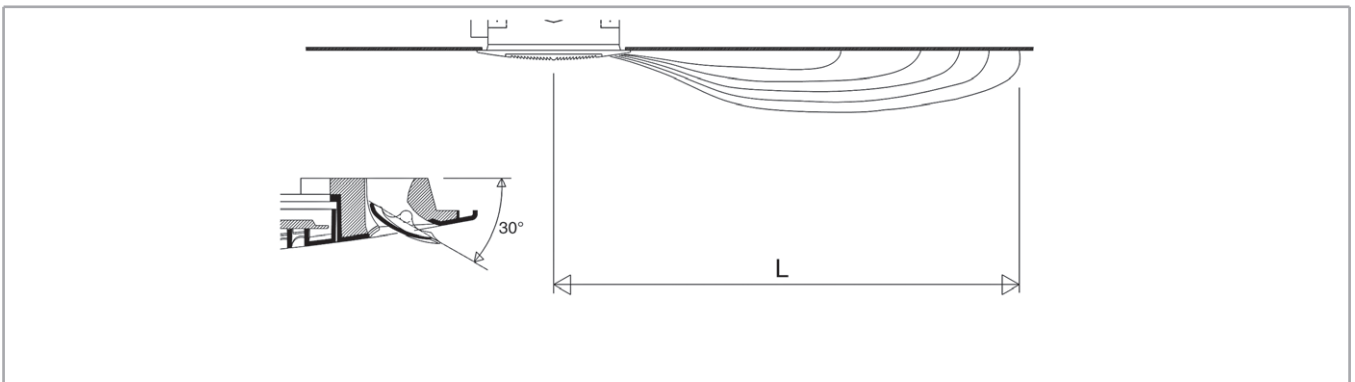

Model	CWE 1-2P - 1-4P			CWE 2-2P - 2-4P			CWE 3-2P - 3-4P			CWE 4-2P - 4-4P			CWE 5-2P - 5-4P			
	Vdc	1	5	10	1	5	10	1	5	10	1	5	10	1	5	10
L	m	3,0	3,5	3,8	3,0	3,8	4,5	3,5	4,2	5,0	3,2	3,7	4,3	3,4	4,0	5,0

Vdc = Inverter power

With adjustable air diffusion louvers at 45°

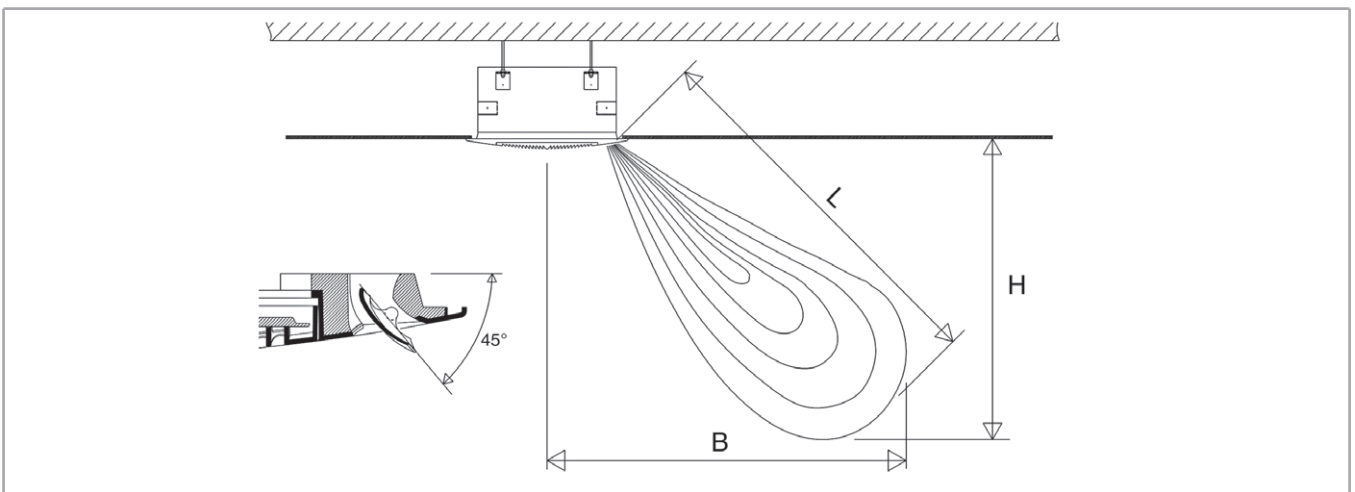

Model	CWE 1-2P - 1-4P			CWE 2-2P - 2-4P			CWE 3-2P - 3-4P			CWE 4-2P - 4-4P			CWE 5-2P - 5-4P			
	Vdc	1	5	10	1	5	10	1	5	10	1	5	10	1	5	10
L	m	3,3	3,9	4,2	3,3	4,2	4,8	3,9	4,5	5,2	3,5	4,1	4,8	3,8	4,6	5,4
H	m	2,2	2,6	2,8	2,2	2,8	3,2	2,6	3,0	3,4	2,2	2,6	3,0	2,4	2,8	3,4
B	m	2,5	2,9	3,1	2,5	3,1	3,6	2,9	3,4	3,9	2,7	3,2	3,8	3,0	3,6	4,2

Vdc = Inverter power

CWE CONTROLS

CWE version

For this Cassette configuration, the 1-10 Vdc signal, which controls the inverter, must be supplied by a controller with the following signal specifications:

Fan drive signal

- Fan OFF = 0 Vdc
- Fan ON > 1 Vdc
- Max. speed = 10 Vdc

Blac-ECM Inverter board

- 0÷10 Vdc Circuit Input Impedance Value = 68kOhm

Power supply

230 Vac 1 Ph 50-60 Hz

Controls

All the units of the **CWE** range can be supplied with a wide range of controls that allows managing one single unit or several units (with the use of the power units).

The room temperature can be controlled through electronic room thermostats, with different solutions according to every ambient conditions.

The **T-AUTO**, **IR-MB** and **T-ECM** electronic thermostats control the room temperature precisely and are suitable when the user wants to set the fan speed.

T-AUTO control (*)



230 V 50-60 Hz

IR-MB control (*)



230 V 50-60 Hz

T-ECM control



230 V 50 Hz

(*) To be used with T-POWER-M or T-POWER-A only

Control systems

See from p. 49 for:

- the MB electronic board (to be fitted on the MB version)
- the MB controls and units

CWE-E VERSION

The 2 pipe model Cassette units are available with electric heater.

The electric heater is controlled in place of the hot water valve and not as integration to it.

The electric heaters are hermetically sealed and supplied inside the coil pipes and therefore can be only factory mounted.

The electric resistances of the units are for single phase

230V supply.

The Cassette fan coil unit includes no. 2 safety thermostats which intervene in case of internal over-heating, opening an auxiliary power relay (included in the electrical panel) which stops the power supply to the electric heaters.

Note: the cooling emission of the units is 95% of the emission in the tables of p. 24.

Constructional features of the electric heater

Model		CWE 1-2P	CWE 2-2P	CWE 3-2P	CWE 4-2P	CWE 5-2P
Emission	W	1500	2500		3000	
Single-phase rated operating voltage	Vac/Ph/Hz	230/1/50				
Connecting wires	n x mm ²	3 x 1,5	3 x 2,5			
Maximum current absorbed	A	7,0	11,0		13,5	
Advised fuse ⁽¹⁾	A	8	12		16	
Max. ambient temperature ⁽²⁾	°C	25				

- (1) for the overheat protection; gG type
 (2) with electric heater in heating mode

CWE-E CONTROL

T-AUTO control (*)



230 V 50-60 Hz

IR-MB control (*)



230 V 50-60 Hz

(*) To be used with T-POWER-M or T-POWER-A only

MAIN COMPONENTS





Air diffuser

Intake grids, frame and adjustable air distribution louvers on each side, made of ABS. In the **CWE-MB** version the outlet louvers are adjustable with infra-red remote control or with IR-MB wall control (for the **CWE** version manually only).

The intake and air distribution grids are available with both, the G0 filter and the **ePM₁ 55% - F7 filter**.

- **DIFF** version white ABS, RAL 9003.
- **DIFF** version in ABS one single color to choose.

Inner casing

It is made of galvanized steel with internal thermal insulation with polyolefin (PO) foam (class M1) and external anti-condensate lining.

Control panel

- **CWE / CWE-EH** version

It consists of the pump control circuit board and the inverter circuit board.

- **CWE-MB / CWE-MB-EH** version

It consists of the MB electronic board (that integrates pump control) and the inverter board.

The diffusion louvers are adjustable with the infra-red remote control or with IR-MB wall control.

Fan assembly

The fan assembly, which is mounted on anti-vibrating supports, is extremely silent.

The radial fan has been designed to optimise performance, using wing profile blades with a shape that reduces turbulence, increasing efficiency and reducing noise.

The fans are connected to a three phase permanent magnet brushless electronic motor that is controlled with reconstructed current according to a BLAC sinusoidal wave.

The inverter board that controls the motor operation is powered by 230 Volt, single-phase and, with a switching system, it generates a three-phase frequency modulated, wave form power supply.

The electric power supply required for the machine is therefore single-phase with voltage of 230 - 240 V and

frequency of 50 - 60 Hz.

Coil

Made of copper tubes with bonded aluminium fins for maximum transfer contact.

3 row coil for 2 pipe models and 2,5 + 1/2 row coil for 4 pipe models (the heating row is on the inside part of the coil).

The heat exchanger is not suitable for use in corrosive atmosphere or in environments where aluminium may be subject to corrosion.

Condensate collection tray

High density polystyrene foam condensate tray, shaped in order to optimize the air diffusion.

Fire retardant rating B1 to DIN 4102.

Filter

Easy access to the filter that is available in both versions, in the G0 (synthetic regenerable washable) and in the ePM₁ 55% - F7 one (to change at the end of its life-cycle).

Condensate pump

Float switch centrifugal pump with 650 mm of maximum head, integral to the unit and wired to the control panel on the outside of the casing.

Valve set

Two or three way valves for ON/OFF operation, with pipe mounting kit and ball valves.



EUROVENT CERTIFICATIONS

2 pipe system

The following standard rating conditions are used:

COOLING

Entering air temperature: + 27 °C d.b. + 19 °C w.b.
Water temperature: +7 °C E.W.T. +12 °C L.W.T.

HEATING

Entering air temperature: + 20 °C
Water temperature: +45 °C E.W.T. +40 °C L.W.T.

MODEL	Inverter power	72					82				
		1 MIN	3	5 MED	7,5	10 MAX	1 MIN	3	5 MED	7,5	10 MAX
Air flow	m ³ /h	790	1040	1290	1600	1905	1025	1340	1650	2060	2480
Cooling total emission (E)	kW	6,36	7,95	9,43	11,10	12,60	7,86	9,72	11,38	13,35	15,13
Cooling sensible emission (E)	kW	4,45	5,65	6,77	8,09	9,31	5,58	7,00	8,30	9,88	11,41
Heating emission (E)	kW	6,18	7,93	9,59	11,55	13,39	7,82	9,91	11,86	14,29	16,40
Dp Cooling (E)	kPa	6,6	9,8	13,4	18,0	22,7	9,6	14,1	18,8	25,2	31,8
Dp Heating (E)	kPa	5,4	8,4	11,8	16,5	21,5	8,2	12,5	17,3	24,2	31,0
Sound power (Lw) (E)	dB(A)	38	44	49	54	58	47	50	55	60	64
Sound pressure (Lp) ⁽¹⁾	dB(A)	29	35	40	45	49	38	41	46	51	55
Motor power input (E)	W	13	22	35	59	93	21	38	64	113	183
Condensate drain pump power absorption	W	10	10	10	10	10	10	10	10	10	10
Water content	l	4,6	4,6	4,6	4,6	4,6	4,6	4,6	4,6	4,6	4,6
Length	mm	869	869	869	869	869	869	869	869	869	869
Depth	mm	869	869	869	869	869	869	869	869	869	869
Height	mm	304	304	304	304	304	304	304	304	304	304

(E) Eurovent certified performance (MIN-MED-MAX speed)

(1) The sound pressure levels are 9 dB (A) lower than the sound power levels, apply to the reverberant field of a 100 m³ room and a reverberation time of 0.5 sec.

4 pipe system

The following standard rating conditions are used:

COOLING

Entering air temperature: + 27 °C d.b. + 19 °C w.b.
Water temperature: +7 °C E.W.T. +12 °C L.W.T.

HEATING

Entering air temperature: + 20 °C
Water temperature: +65 °C E.W.T. +55 °C L.W.T.

MODEL	Inverter power	76					86				
		1 MIN	3	5 MED	7,5	10 MAX	1 MIN	3	5 MED	7,5	10 MAX
Air flow	m ³ /h	790	1040	1290	1600	1905	1025	1340	1650	2060	2480
Cooling total emission (E)	kW	6,07	7,53	8,86	10,35	11,61	7,45	9,10	10,59	12,30	13,59
Cooling sensible emission (E)	kW	4,33	5,46	6,53	7,74	8,87	5,40	6,73	7,96	9,44	10,68
Heating emission (E)	kW	6,01	7,27	8,40	9,63	10,55	7,19	8,62	9,80	11,05	12,17
Dp Cooling (E)	kPa	7,0	10,3	13,8	18,3	22,6	10,1	14,5	19,1	25,2	30,4
Dp Heating (E)	kPa	7,2	10,2	13,2	16,9	19,9	10,0	13,8	17,4	21,6	25,7
Sound power (Lw) (E)	dB(A)	38	44	49	54	58	47	50	55	60	64
Sound pressure (Lp) ⁽¹⁾	dB(A)	29	35	40	45	49	38	41	46	51	55
Motor power input (E)	W	13	22	35	59	93	21	38	64	113	183
Condensate drain pump power absorption	W	10	10	10	10	10	10	10	10	10	10
Cooling water content	l	3,6	3,6	3,6	3,6	3,6	3,6	3,6	3,6	3,6	3,6
Heating water content	l	1,2	1,2	1,2	1,2	1,2	1,2	1,2	1,2	1,2	1,2
Length	mm	869	869	869	869	869	869	869	869	869	869
Depth	mm	869	869	869	869	869	869	869	869	869	869
Height	mm	304	304	304	304	304	304	304	304	304	304

(E) Eurovent certified performance (MIN-MED-MAX speed)

(1) The sound pressure levels are 9 dB (A) lower than the sound power levels, apply to the reverberant field of a 100 m³ room and a reverberation time of 0.5 sec.

COOLING EMISSION

Entering air temperature: 27 °C – R.H.: 50%

Model	Vdc	WT: 7 / 12 °C					WT: 8 / 13 °C					WT: 10 / 15 °C				WT: 12 / 17 °C			
		Qv m ³ /h	Pc kW	Ps kW	Qw l/h	Dp(c) kPa	Pc kW	Ps kW	Qw l/h	Dp(c) kPa	Pc kW	Ps kW	Qw l/h	Dp(c) kPa	Pc kW	Ps kW	Qw l/h	Dp(c) kPa	
72	10	1905	13,52	9,25	2341	25,7	12,21	8,73	2116	21,3	9,70	7,68	1684	14,0	6,96	6,96	1213	7,7	
	7,5	1600	11,90	8,07	2058	20,4	10,77	7,59	1862	16,9	8,58	6,69	1486	11,2	6,63	5,86	1150	7,0	
	5	1290	10,11	6,77	1744	15,1	9,14	6,36	1577	12,6	7,31	5,60	1264	8,3	5,65	4,90	978	5,2	
	3	1040	8,52	5,65	1470	11,1	7,74	5,32	1335	9,3	6,19	4,66	1068	6,2	4,77	4,08	825	3,8	
	1	790	6,80	4,45	1172	7,4	6,19	4,19	1067	6,2	4,99	3,68	860	4,2	3,85	3,22	665	2,6	
82	10	2480	16,21	11,31	2819	35,9	14,60	10,67	2543	29,7	11,59	9,41	2025	19,5	8,49	8,49	1491	11,1	
	7,5	2060	14,28	9,84	2476	28,5	12,92	9,28	2242	23,6	10,23	8,17	1779	15,4	7,39	7,39	1291	8,6	
	5	1650	12,18	8,27	2106	21,3	11,03	7,79	1907	17,7	8,74	6,85	1515	11,5	6,78	6,01	1177	7,2	
	3	1340	10,41	6,98	1797	16,0	9,43	6,57	1628	13,3	7,51	5,77	1299	8,8	5,81	5,06	1005	5,5	
	1	1025	8,42	5,58	1453	10,9	7,64	5,25	1318	9,1	6,13	4,61	1057	6,0	4,73	4,03	816	3,8	
76	10	1905	12,40	8,78	2149	25,5	11,20	8,31	1942	21,1	8,93	7,36	1553	13,9	6,65	6,65	1160	8,2	
	7,5	1600	11,03	7,69	1908	20,6	10,01	7,28	1731	17,2	7,97	6,43	1381	11,3	5,83	5,83	1013	6,4	
	5	1290	9,47	6,49	1635	15,6	8,57	6,11	1480	12,9	6,84	5,40	1183	8,6	5,32	4,75	921	5,4	
	3	1040	8,07	5,44	1391	11,6	7,30	5,13	1259	9,7	5,82	4,51	1005	6,4	4,53	3,97	782	4,0	
	1	790	6,50	4,32	1121	7,9	5,88	4,06	1014	6,6	4,73	3,57	816	4,4	3,67	3,14	634	2,8	
86	10	2480	14,48	10,52	2522	34,0	13,08	9,98	2281	28,2	10,41	8,85	1822	18,6	7,94	7,94	1396	11,4	
	7,5	2060	13,05	9,31	2264	28,0	11,81	8,82	2051	23,3	9,40	7,81	1635	15,3	7,04	7,04	1231	9,1	
	5	1650	11,27	7,87	1949	21,4	10,22	7,45	1768	17,8	8,13	6,58	1409	11,7	5,97	5,97	1038	6,7	
	3	1340	9,74	6,69	1681	16,4	8,82	6,30	1524	13,6	7,04	5,57	1217	9,0	5,47	4,90	947	5,7	
	1	1025	7,98	5,38	1376	11,4	7,22	5,07	1246	9,5	5,79	4,47	1000	6,3	4,48	3,92	774	3,9	

WT: Water temperature
Vdc: Inverter power
Qv: Air flow
Pc: Cooling total emission
Ps: Cooling sensible emission
Qw: Water flow rate
Dp(c): Dp Cooling

Entering air temperature 26 °C – R.H.: 50%

Model	Vdc	WT: 7 / 12 °C					WT: 8 / 13 °C				WT: 10 / 15 °C				WT: 12 / 17 °C			
		Qv m ³ /h	Pc kW	Ps kW	Qw l/h	Dp(c) kPa	Pc kW	Ps kW	Qw l/h	Dp(c) kPa	Pc kW	Ps kW	Qw l/h	Dp(c) kPa	Pc kW	Ps kW	Qw l/h	Dp(c) kPa
72	10	1905	12,13	8,75	2102	21,2	10,85	8,19	1883	17,3	8,55	7,21	1487	11,2	6,39	6,39	1116	6,6
	7,5	1600	10,67	7,61	1846	16,8	9,56	7,13	1655	13,7	7,57	6,28	1311	8,9	5,58	5,58	971	5,1
	5	1290	9,07	6,38	1565	12,5	8,16	5,98	1410	10,3	6,45	5,25	1115	6,6	4,70	4,70	814	3,7
	3	1040	7,67	5,33	1322	9,2	6,90	4,99	1190	7,6	5,46	4,38	943	4,9	4,17	3,82	721	3,0
	1	790	6,13	4,21	1056	6,1	5,53	3,94	954	5,1	4,39	3,45	757	3,3	3,36	3,01	580	2,0
82	10	2480	14,49	10,67	2523	29,4	12,94	10,03	2257	23,9	10,26	8,85	1797	15,7	7,78	7,78	1370	9,5
	7,5	2060	12,78	9,30	2218	23,3	11,44	8,72	1988	19,0	9,04	7,68	1574	12,4	6,79	6,79	1187	7,4
	5	1650	10,93	7,80	1891	17,5	9,78	7,31	1694	14,3	7,72	6,43	1338	9,2	5,72	5,72	995	5,4
	3	1340	9,35	6,59	1615	13,2	8,40	6,17	1451	10,8	6,63	5,42	1147	7,0	4,84	4,84	840	3,9
	1	1025	7,58	5,27	1307	9,0	6,82	4,94	1176	7,4	5,40	4,32	932	4,8	4,12	3,77	713	2,9
76	10	1905	11,14	8,33	1932	21,0	9,94	7,83	1725	17,0	7,93	6,93	1380	11,3	6,10	6,10	1065	7,0
	7,5	1600	9,95	7,30	1721	17,1	8,88	6,84	1538	13,9	7,04	6,04	1221	9,0	5,35	5,35	931	5,5
	5	1290	8,52	6,13	1471	12,9	7,62	5,76	1317	10,5	6,03	5,07	1043	6,8	4,53	4,53	785	4,0
	3	1040	7,25	5,15	1251	9,6	6,51	4,82	1124	7,9	5,15	4,24	889	5,1	3,80	3,80	658	2,9
	1	790	5,85	4,08	1009	6,5	5,27	3,83	909	5,4	4,18	3,36	722	3,5	3,21	2,94	555	2,2
86	10	2480	13,03	10,00	2272	28,1	11,64	9,41	2033	22,9	8,61	8,61	1512	13,3	7,26	7,26	1280	9,7
	7,5	2060	11,76	8,85	2042	23,2	10,50	8,31	1825	18,9	8,33	7,35	1452	12,4	6,45	6,45	1129	7,8
	5	1650	10,16	7,47	1758	17,7	9,07	7,00	1571	14,4	7,17	6,19	1244	9,4	5,48	5,48	954	5,7
	3	1340	8,77	6,34	1514	13,6	7,83	5,94	1353	11,0	6,19	5,23	1071	7,1	4,67	4,67	809	4,3
	1	1025	7,17	5,08	1237	9,4	6,45	4,76	1112	7,7	5,11	4,20	882	5,0	3,76	3,76	650	2,9

- WT:** Water temperature
- Vdc:** Inverter power
- Qv:** Air flow
- Pc:** Cooling total emission
- Ps:** Cooling sensible emission
- Qw:** Water flow rate
- Dp(c):** Dp Cooling

Entering air temperature: 25 °C – R.H.: 50%

Model	Vdc	WT: 7 / 12 °C					WT: 8 / 13 °C					WT: 10 / 15 °C					WT: 12 / 17 °C				
		Qv m ³ /h	Pc kW	Ps kW	Qw l/h	Dp(c) kPa	Pc kW	Ps kW	Qw l/h	Dp(c) kPa	Pc kW	Ps kW	Qw l/h	Dp(c) kPa	Pc kW	Ps kW	Qw l/h	Dp(c) kPa			
72	10	1905	10,80	8,21	1874	17,2	9,64	7,70	1674	14,0	7,53	6,75	1310	8,9	5,82	5,82	1018	5,6			
	7,5	1600	9,51	7,15	1646	13,6	8,52	6,72	1476	11,1	6,63	5,87	1151	7,0	5,09	5,09	886	4,4			
	5	1290	8,11	6,00	1401	10,2	7,25	5,62	1254	8,3	5,65	4,92	977	5,2	4,29	4,29	744	3,2			
	3	1040	6,86	5,01	1184	7,5	6,13	4,69	1059	6,1	4,79	4,10	827	3,9	3,59	3,59	622	2,3			
	1	790	5,50	3,96	948	5,1	4,93	3,70	851	4,1	3,85	3,23	665	2,6	2,86	2,86	495	1,5			
82	10	2480	12,91	10,07	2251	24,0	11,54	9,45	2016	19,5	8,49	8,49	1492	11,2	7,07	7,07	1247	8,0			
	7,5	2060	11,41	8,73	1981	19,0	10,17	8,21	1769	15,4	7,40	7,40	1292	8,7	6,18	6,18	1082	6,2			
	5	1650	9,75	7,33	1688	14,3	8,70	6,88	1508	11,6	6,78	6,02	1177	7,3	5,22	5,22	908	4,5			
	3	1340	8,35	6,19	1442	10,8	7,46	5,80	1290	8,7	5,81	5,07	1006	5,5	4,43	4,43	768	3,4			
	1	1025	6,79	4,95	1171	7,4	6,08	4,64	1050	6,0	4,73	4,05	818	3,8	3,55	3,55	615	2,3			
76	10	1905	9,94	7,84	1726	17,2	8,89	7,38	1545	14,0	6,65	6,65	1160	8,3	5,54	5,54	969	5,9			
	7,5	1600	8,82	6,86	1528	13,8	7,91	6,44	1370	11,3	5,84	5,84	1014	6,5	4,87	4,87	848	4,6			
	5	1290	7,59	5,77	1311	10,5	6,81	5,42	1177	8,6	5,32	4,76	921	5,4	4,13	4,13	716	3,4			
	3	1040	6,49	4,84	1119	7,9	5,78	4,54	999	6,4	4,53	3,98	782	4,1	3,47	3,47	601	2,5			
	1	790	5,24	3,84	903	5,3	4,69	3,59	809	4,4	3,68	3,15	635	2,8	2,78	2,78	481	1,7			
86	10	2480	11,61	9,42	2028	22,9	10,38	8,87	1816	18,7	7,93	7,93	1396	11,5	6,58	6,58	1163	8,2			
	7,5	2060	10,47	8,31	1821	18,9	9,36	7,83	1629	15,4	7,05	7,05	1231	9,2	5,86	5,86	1027	6,6			
	5	1650	9,03	7,01	1564	14,4	8,07	6,59	1399	11,7	5,97	5,97	1039	6,8	4,99	4,99	869	4,8			
	3	1340	7,79	5,95	1347	11,0	6,99	5,59	1209	9,0	5,48	4,91	948	5,7	4,25	4,25	738	3,6			
	1	1025	6,41	4,78	1106	7,7	5,72	4,48	988	6,2	4,48	3,93	774	4,0	3,43	3,43	594	2,4			

WT: Water temperature
Vdc: Inverter power
Qv: Air flow
Pc: Cooling total emission
Ps: Cooling sensible emission
Qw: Water flow rate
Dp(c): Dp Cooling

HEATING EMISSION

Entering air temperature: 20 °C

Model	Vdc	WT: 65 / 55 °C				WT: 60 / 50 °C			WT: 50 / 40 °C			WT: 50 / 45 °C			WT: 45 / 40 °C		
		Qv m³/h	Ph kW	Qw l/h	Dp(h) kPa	Ph kW	Qw l/h	Dp(h) kPa	Ph kW	Qw l/h	Dp(h) kPa	Ph kW	Qw l/h	Dp(h) kPa	Ph kW	Qw l/h	Dp(h) kPa
72	10	1905	24,08	2070	17,0	21,08	1813	13,5	15,06	1295	7,6	16,34	2810	30,4	13,39	2302	21,5
	7,5	1600	20,78	1787	13,0	18,21	1566	10,4	13,05	1122	5,9	14,08	2421	23,2	11,55	1987	16,5
	5	1290	17,25	1483	9,3	15,14	1302	7,5	10,90	937	4,2	11,67	2007	16,6	9,59	1649	11,8
	3	1040	14,26	1226	6,6	12,54	1078	5,3	9,06	779	3,0	9,63	1656	11,7	7,93	1363	8,4
	1	790	11,12	956	4,2	9,79	842	3,4	7,11	611	2,0	7,49	1289	7,5	6,18	1063	5,4
82	10	2480	29,49	2536	24,4	25,79	2218	19,4	18,33	1577	10,8	20,06	3450	43,9	16,40	2821	31,0
	7,5	2060	25,69	2210	19,1	22,49	1934	15,2	16,04	1379	8,5	17,45	3001	34,2	14,29	2457	24,2
	5	1650	21,33	1834	13,6	18,69	1608	10,9	13,39	1151	6,1	14,45	2486	24,4	11,86	2039	17,3
	3	1340	17,83	1533	9,9	15,65	1346	7,9	11,25	968	4,5	12,06	2075	17,6	9,91	1705	12,5
	1	1025	14,08	1211	6,5	12,38	1064	5,2	8,94	769	3,0	9,50	1635	11,5	7,82	1346	8,2

WT: Water temperature
Vdc: Inverter power
Qv: Air flow
Ph: Heating emission
Qw: Water flow rate
Dp(h): Dp Heating

Entering air temperature: 20 °C

Model	Vdc	WT: 70 / 60 °C				WT: 60 / 50 °C			WT: 50 / 40 °C			WT: 50 / 45 °C			WT: 45 / 40 °C		
		Qv m³/h	Ph kW	Qw l/h	Dp(h) kPa	Ph kW	Qw l/h	Dp(h) kPa	Ph kW	Qw l/h	Dp(h) kPa	Ph kW	Qw l/h	Dp(h) kPa	Ph kW	Qw l/h	Dp(h) kPa
76	10	1905	12,04	1036	24,9	9,07	780	15,3	6,10	525	7,7	7,36	1266	37,4	5,89	1014	25,5
	7,5	1600	10,98	944	21,1	8,28	712	13,0	5,58	480	6,6	6,71	1155	31,7	5,38	925	21,6
	5	1290	9,58	824	16,5	7,23	621	10,2	4,88	420	5,2	5,85	1007	24,8	4,69	807	16,9
	3	1040	8,28	712	12,7	6,25	538	7,9	4,23	364	4,0	5,06	870	19,1	4,06	698	13,0
	1	790	6,84	588	9,0	5,17	445	5,6	3,51	301	2,9	4,18	719	13,5	3,35	577	9,2
86	10	2480	13,89	1195	32,3	10,45	899	19,8	7,02	604	10,0	8,50	1461	48,5	6,80	1169	32,9
	7,5	2060	12,61	1085	27,1	9,49	817	16,7	6,39	549	8,4	7,71	1326	40,7	6,17	1062	27,7
	5	1650	11,18	961	21,8	8,42	724	13,4	5,68	488	6,8	6,83	1176	32,8	5,48	942	22,3
	3	1340	9,83	845	17,3	7,41	637	10,7	5,00	430	5,4	6,00	1033	25,9	4,81	828	17,7
	1	1025	8,20	705	12,5	6,19	532	7,7	4,19	360	3,9	5,01	862	18,7	4,02	691	12,8

WT: Water temperature
Vdc: Inverter power
Qv: Air flow
Ph: Heating emission
Qw: Water flow rate
Dp(h): Dp Heating

WATER SIDE PRESSURE DROP

2 pipe system

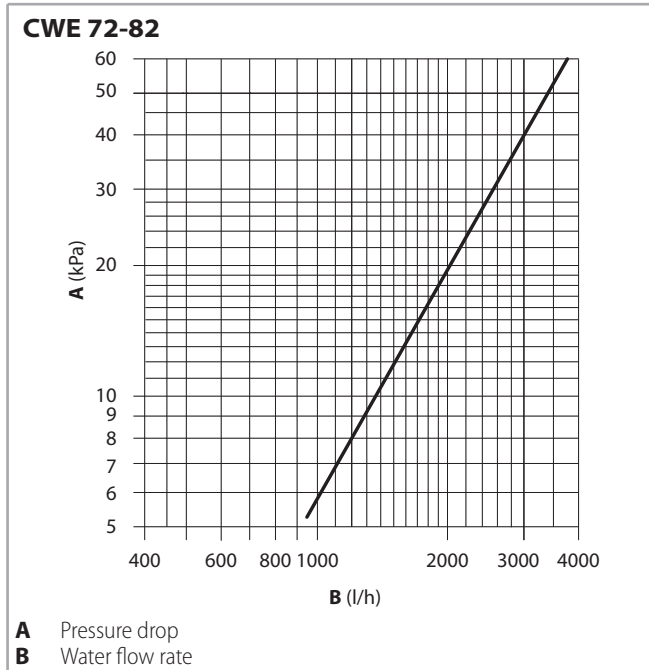

Pressure drop for mean water temperature of 10 °C, for different temperatures multiply the pressure drop figure by the K correction factors in the table.

	Mean water temperature (°C)						
	20	30	40	50	60	70	80
K correction factor	0,94	0,90	0,86	0,82	0,78	0,74	0,70

4 pipe system

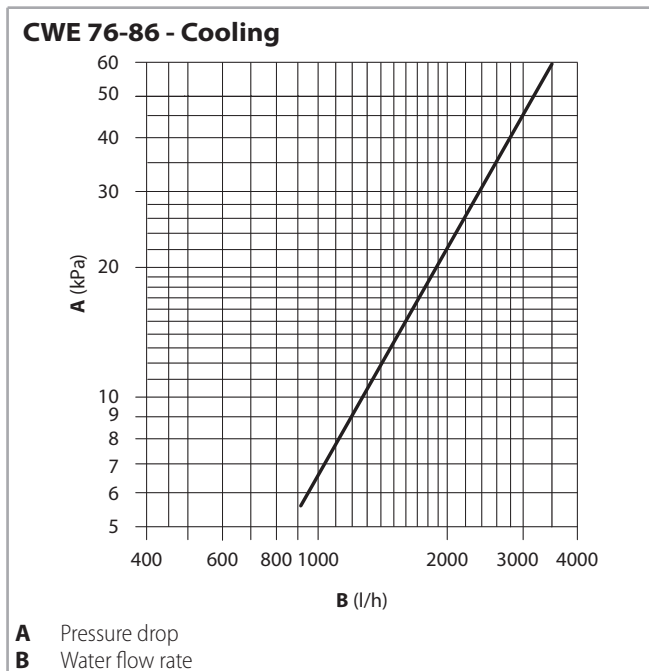

Pressure drop for mean water temperature of 10 °C, for different temperatures multiply the pressure drop figure by the K correction factors in the table.

	Mean water temperature (°C)						
	20	30	40	50	60	70	80
K correction factor	0,94	0,90	0,86	0,82	0,78	0,74	0,70

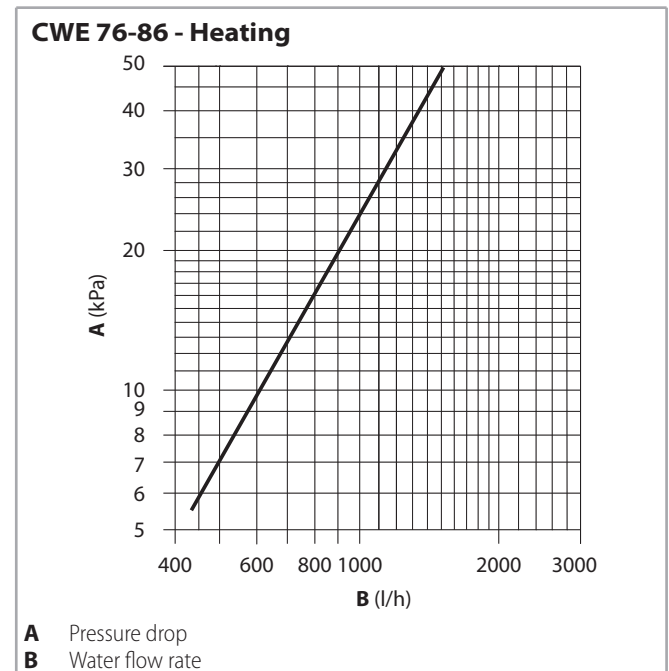

Pressure drop for mean water temperature of 60 °C, for different temperatures multiply the pressure drop figure by the K correction factors in the table.

	Mean water temperature (°C)			
	40	50	70	80
K correction factor	1,12	1,06	0,94	0,88

OPERATING LIMITS

Description	UoM	Value
Water flow	Highest working pressure	bars
		kPa
	Lowest water inlet temperature	°C
	Highest water inlet temperature mod. 72-82	°C
		+6
		+65
		+80
Power supply	Single-phase rated operating voltage	V/Hz
		230/50-60

For maximum installation height, see p. 46.

Filter

ePM₁ 55% - F7 filter

Micro-pleated synthetic filter dimension 578x578x24 mm.

The filtering media is made of (PP+PS) polystyrene and

polypropilene. The very big micro-pleated filtering surface increases the emissions and reduces the pressure drops.

Air flow Qv (m ³ /h)	700	1000	1300	1600	1900	2200
Efficiency	70%	70%	65%	65%	55%	55%

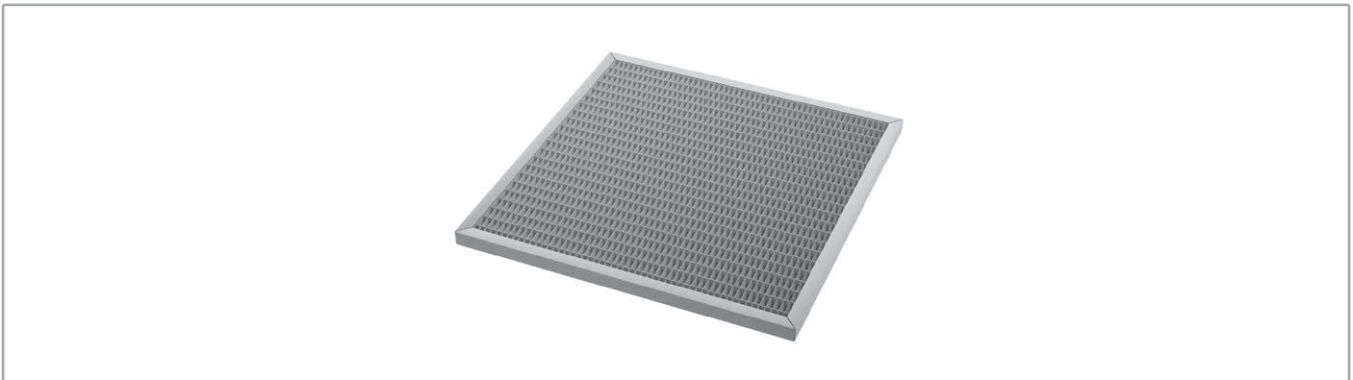

DIMENSION AND WEIGHT

CWE 72-76 / CWE 82-86

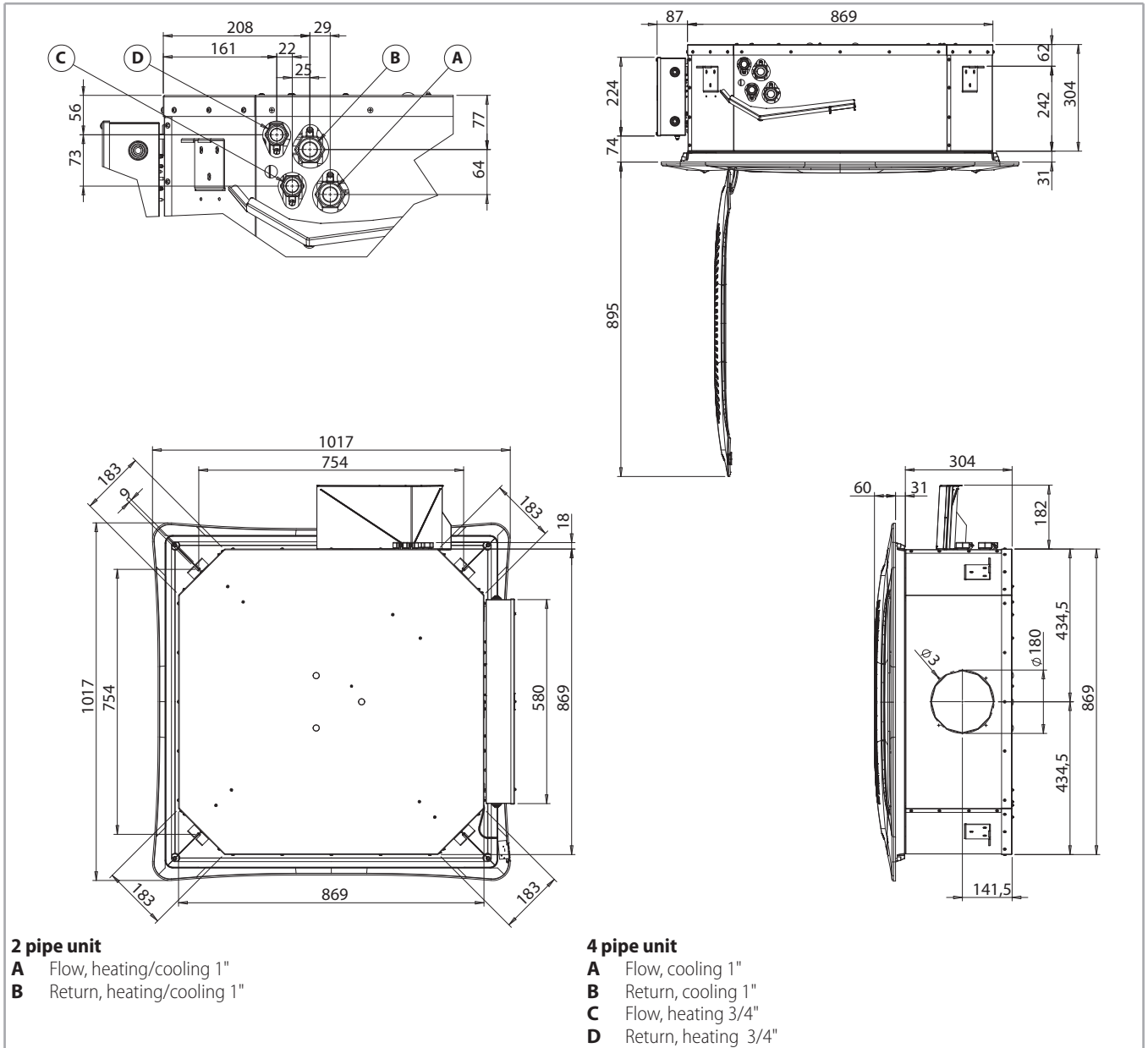

Packed unit

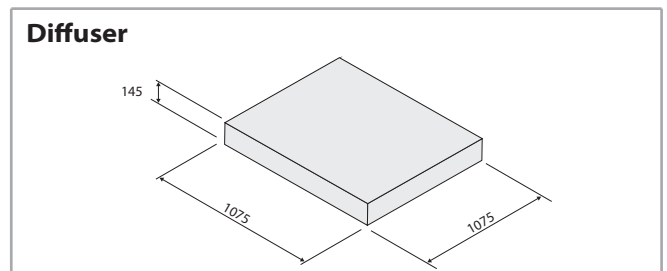
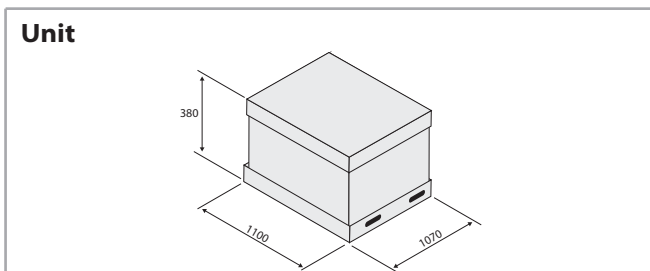

Weight/Model		72	76	82	86
With packaging	kg			52	
Without packaging	kg			42	

Weight/Model		72	76	82	86
With packaging	kg			9,4	
Without packaging	kg			7,5	

AIR THROW

The air throw indicated in the tables must only be considered the maximum value, as it may change significantly in relation to the dimensions of the room in which the appliance is installed and the positioning of the furniture in the room.

The useful throw L refers to the distance between the unit and the point where the air speed is 0.2 m/sec; if the louver has a gradient of 40° (recommended in cooling mode), the so-called "coanda" effect will occur,

illustrated in the first figure, while at a gradient of 60° (recommended in heating mode), there will be a downwards throw, as illustrated in the second figure.

Note: on heating it must be paid attention to rooms where the floor temperature is particularly low (for example less than 5 °C). In this situation the floor can cool the lower layer of air to a level that stops the uniform diffusion of the hot air coming from the unit, decreasing the throw figures shown in the table.

With adjustable air diffusion louvers at 40°

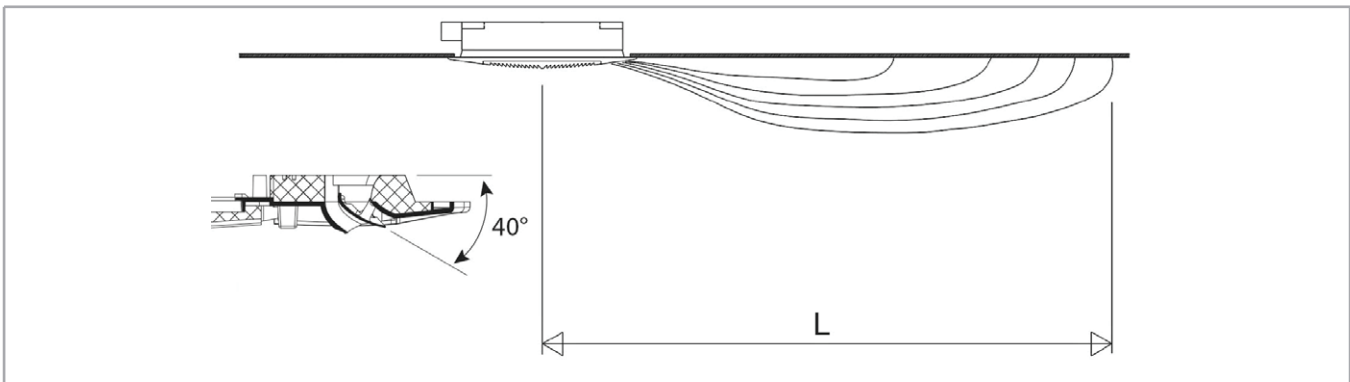

Model	CWE 72-76			CWE 82-86			
Vdc	1	5	10	1	5	10	
L	m	3,5	5,0	6,5	4,0	6,0	7,5

Vdc = Inverter power

With adjustable air diffusion louvers at 60°

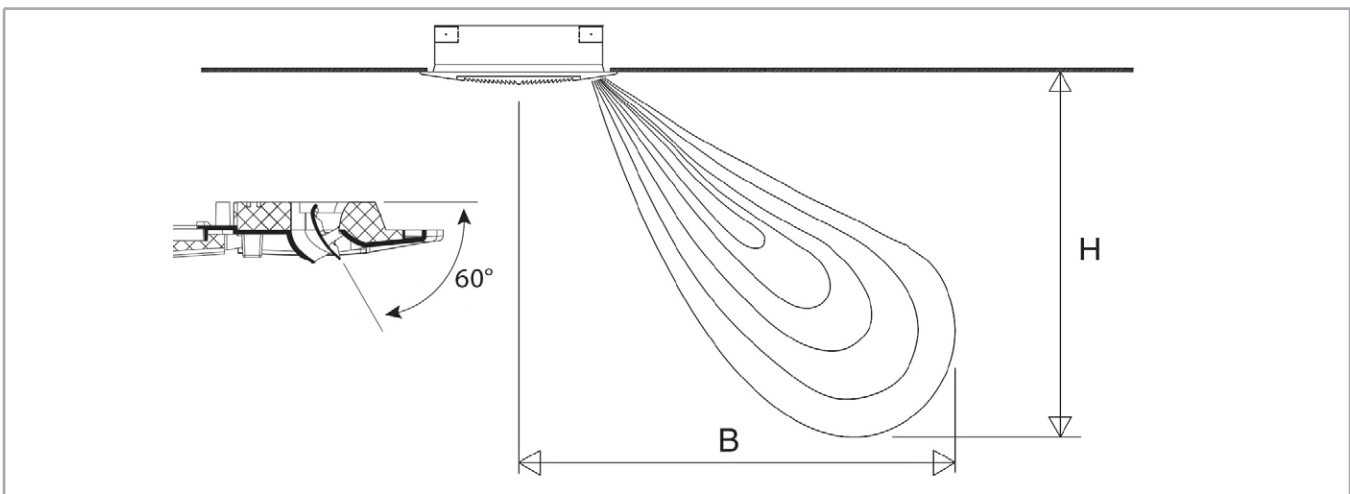

Model	CWE 72-76			CWE 82-86			
Vdc	1	5	10	1	5	10	
H	m	3,1	3,6	4,1	3,5	4,0	4,7
B	m	3,5	4,5	5,5	4,0	5,0	6,5

Vdc = Inverter power

CWE 7-8 CONTROLS

CWE 7-8 version

For this Cassette configuration, the 1-10 Vdc signal, which controls the inverter, must be supplied by a controller with the following signal specifications:

Fan drive signal

- Fan OFF = 0 Vdc
- Fan ON > 1 Vdc
- Max. speed = 10 Vdc

Blac-ECM Inverter board

- 0÷10 Vdc Circuit Input Impedance Value = 96 kOhm

Power supply

230Vac 1Ph 50-60Hz

Controls

All the units of the **CWE 7-8** range can be supplied with a wide range of controls that allows managing one single unit or several units (with the use of the power units).

The room temperature can be controlled through electronic room thermostats, with different solutions according to every ambient conditions.

The **T-AUTO**, **IR-MB** and **T-ECM** electronic thermostats control the room temperature precisely and are suitable when the user wants to set the fan speed.

T-AUTO control (*)



230 V 50-60 Hz

IR-MB control (*)



230 V 50-60 Hz

T-ECM control



230 V 50 Hz

(*) To be used with T-POWER-M or T-POWER-A only

Control systems

See from p. 49 for:

- the MB electronic board (to be fitted on the MB version)
- the MB controls and units

CWE 7-8-E VERSION

The 2 pipe model Cassette units are available with electric heater.

The electric heater is controlled in place of the hot water valve and not as integration to it.

The electric heaters are hermetically sealed and supplied inside the coil pipes and therefore can be only factory mounted.

The electric heaters of the unit can be for 230Vac 1Ph

50-60Hz or 400Vac 3Ph 50-60Hz supply.

The Cassette fan coil unit includes no. 2 safety thermostats which intervene in case of internal over-heating, opening an auxiliary power relay (included in the electrical panel) which stops the power supply to the electric heaters.

Note: the cooling emission of the units is 95% of the emission in the tables of p. 39.

Model		72	76	82	86
Emission	W	3000			
Single-phase rated operating voltage	Vac/Ph/Hz	230/1/50			
Rated three phase connection	Vac/Ph/Hz	400/3/50			
Connecting wires	n x mm ²	3 x 2,5			
Maximum single-phase current absorbed	A	13,5			
Maximum three-phase current absorbed	A	4,5			
Single-phase advised fuse ⁽¹⁾	A	16			
Three-phase advised fuse ⁽¹⁾	A	6			
Max. ambient temperature ⁽²⁾	°C	25			

- (1) for the overheat protection; gG type with electric heater in heating mode
- (2)

CWE 7-8-E controls

T-AUTO control (*)



230 V 50-60 Hz

IR-MB control (*)



230 V 50-60 Hz

(*) To be used with T-POWER-M or T-POWER-A only

CONTROLS

MB electronic board

The MB electronic board, to be mounted on the **CWS-MB**, **CWE-MB** and **CWE-MB-EH** versions, is set to carry out different functions and adjustment modes, in order to meet the installation requirements.

The Dip Switches on the board have to be set to carry out different functions:

- 2/4 pipe unit
- electronic room thermostat or automatic fan speed modulation for fan control (ON-OFF)
- electronic room thermostat for valve control (ON-OFF) (the fan keeps working)
- simultaneous thermostatic control of the valves and fan
- fan operation control depending on the coil temperature (cut-out T3 probe fitted), which can be activated only in heating mode or heating and cooling mode
- automatic switch of the operating mode by means of T2 water probe (optional) applied on the 2 pipe system
- seasonal switch by means of remote contact
- ON/OFF of the fan coil by means of the remote contact (window or clock contact)
- electric heater control

By activating the cut-out T3 probe function, the fan is stopped in winter when the coil temperature is lower than 32 °C and started when the temperature reaches 36 °C. In summer mode, the fan stops when inside the coil exceeds 22 °C and starts when it drops below 18 °C.

The following connections are located on the power board:

- receiver for infra-red remote control
- IR-MB wall control
- serial connection to manage several fan coil units in Master/Slave configuration or to create a supervisory network.

CWS / CWE

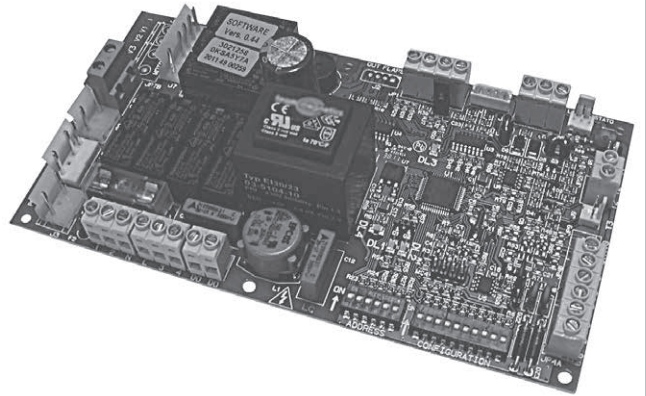

CWE 7-8

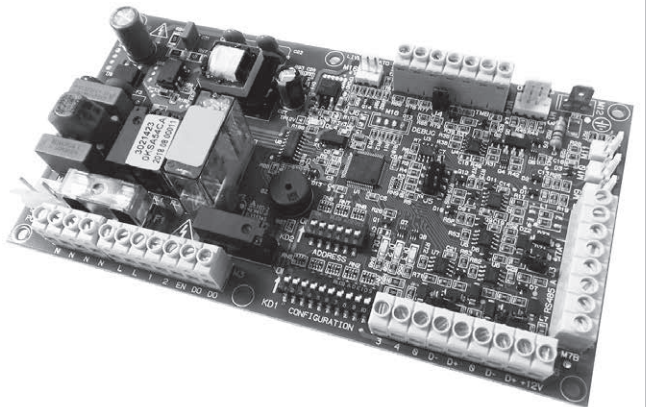

MB controls and units

All the units **CWS**, **CWE** and **CWE 7-8** can be supplied in **MB** version. This version includes a wide range of controls, including the infra-red remote control, which allows managing one single unit or several units by using the Modbus RTU - RS 485 communication protocol. Units can be managed according to the Master/Slave logic (up to 20 units) or by supervisory components. The system includes a single MB power board and a range of technical devices to be used with:

- the **IR-MB** wall control and the **RT03-A infra-red remote control** remote control, to manage single units;
- the **TODS** multifunctional panel and the **NET** supervisory system, to manage one single unit or several units.

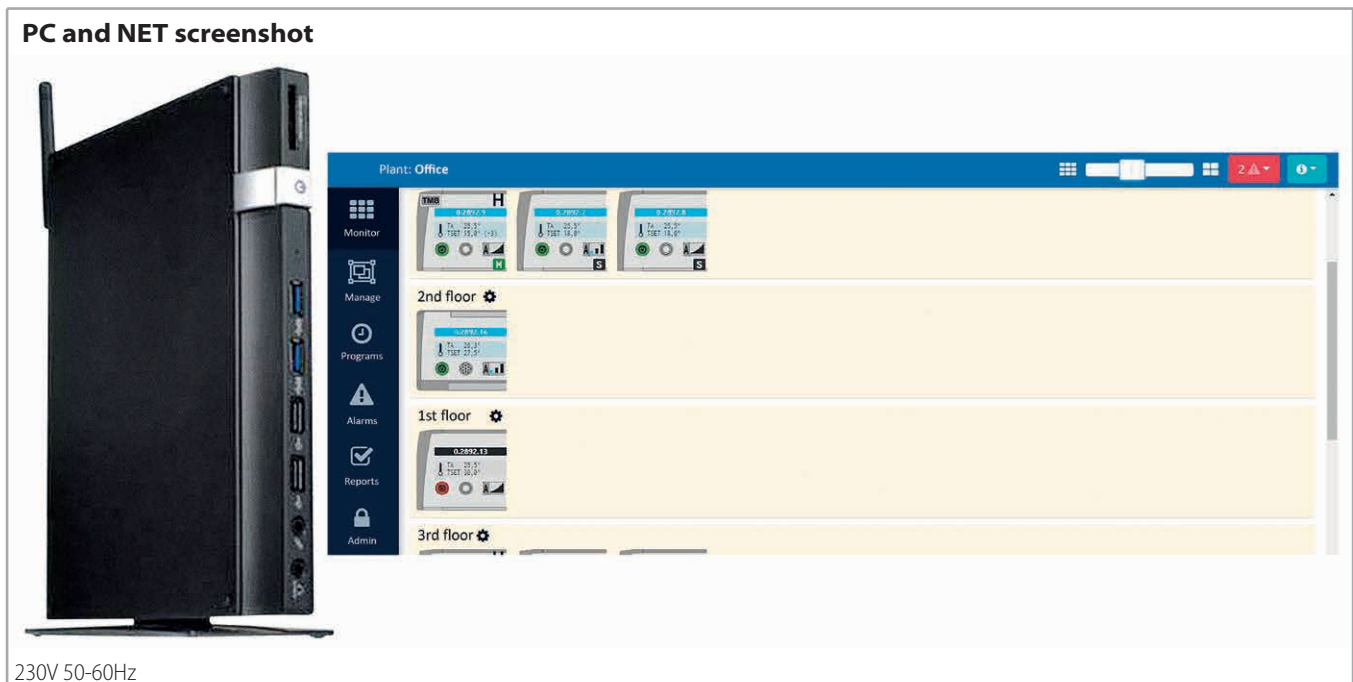

TODS multifunction control panel

With the TODS multifunction control panel it is possible to manage up to 60 units that are equipped with MB electronic board or ROB-A (max. 60 units: ROB-A + MB). The TODS multifunction control panel supervises via Bus network all the connected units. The remote connection (stand-alone) is not possible.



FRESH AIR AND FAC ACCESSORY

Fresh air

To be used with 0-1-2-3 models only.

The Cassette fan coil units is fitted with inlets for fresh air to be mixed with return air inside the unit (except CWE 7-8).

The fresh air flow is limited to 20% of the total fan coil air flow at medium speed and 100 m³/h for each treated air inlet.

The units feature fresh air inlets on three corners (no inlets on the fourth corner because of the condensate pump inside the unit).

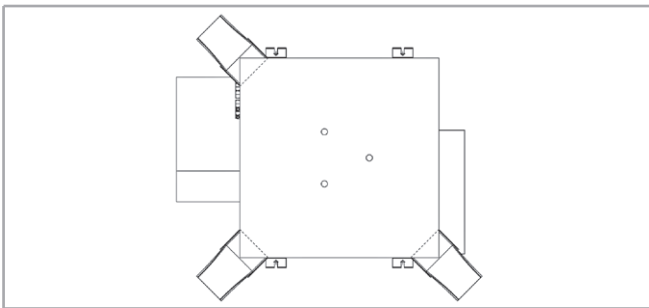

The fresh air inlets are designed for the insertion of standard 110x55 mm rectangular ducts or for the circular ducts fresh air connection FAC below illustrated.

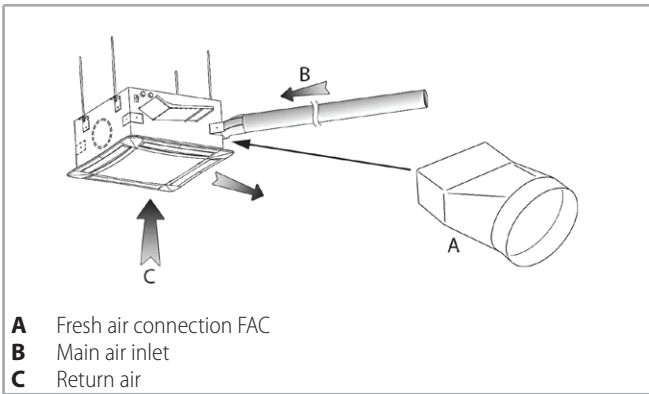

The fresh air is conveyed into the radial fan and mixed to the return air.

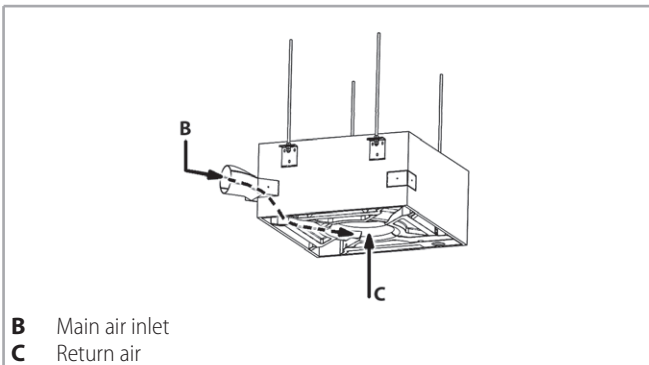

Note: the fresh air must be filtered.

Fresh air connection

Not suitable for MCT models with outer casing.

Model	ID	Code
0-1-2-3	FAC	6078005

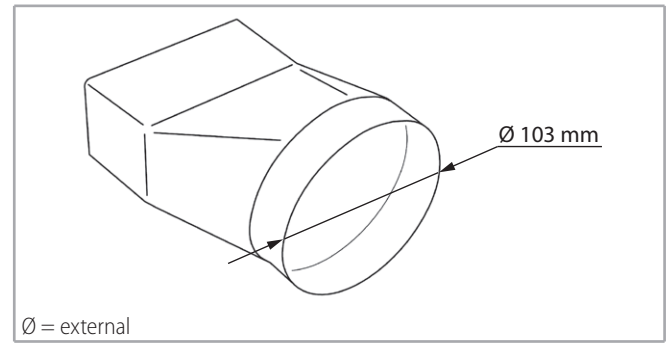

The air duct is connected quickly and easily. After removing the blank and the insulation inside the unit, the mounting plate is rolled back and the air duct with its V-shaped section must be pushed into the unit. The duct is then fixed to the mounting plate.

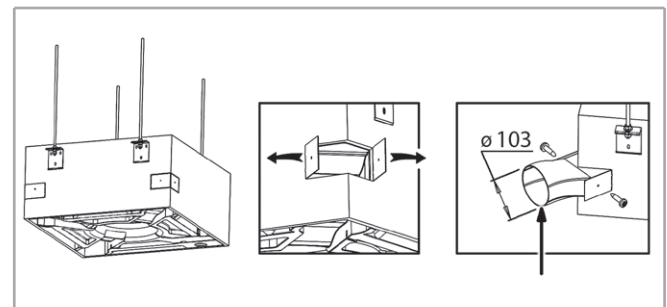

ACCESSORIES

Air distribution connection

Not suitable for MCT models with outer casing.

Model	ID	Code
0-1-2-3	CDA 600	9079232
4-5-6-7-8	CDA 800	9079233

On Cassette fan coils two air outlets are provided on the side of the unit for connection to separate supply air outlets. The total air flow does not change.

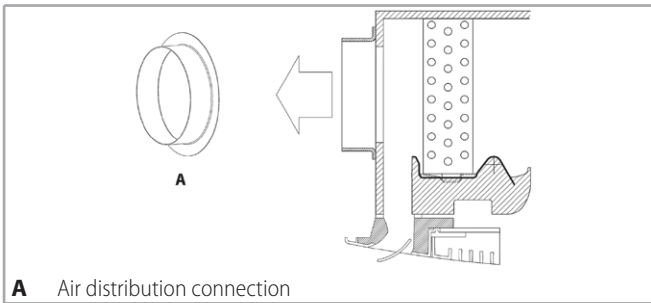

A Air distribution connection

The air distribution connection diameters are:

Model	0-1-2-3	4-5-6-7-8	
∅ fitting	mm	150	180

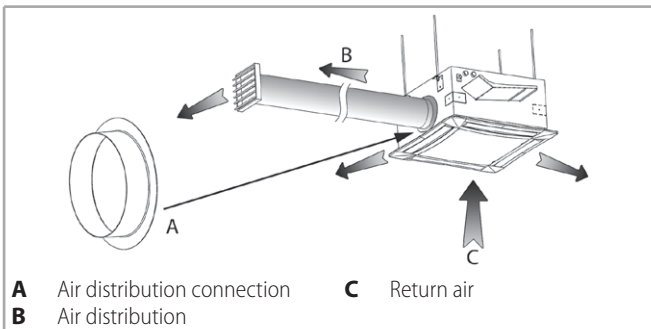

A Air distribution connection
B Air distribution

C Return air

The air flow at high speed depending on the air duct pressure drop is shown in the tables below.

Note: all air ducts must be insulated in order to avoid condensation.

Air distribution connection pressure drop

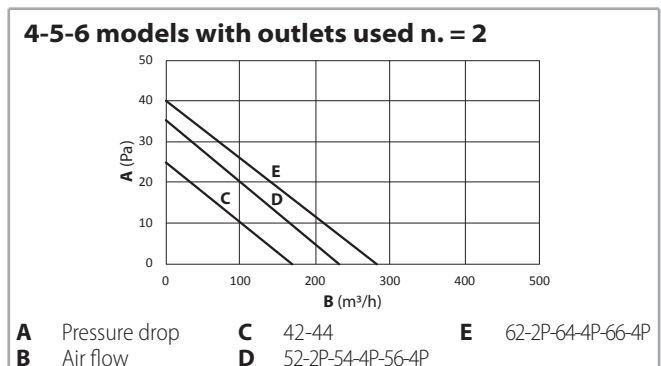
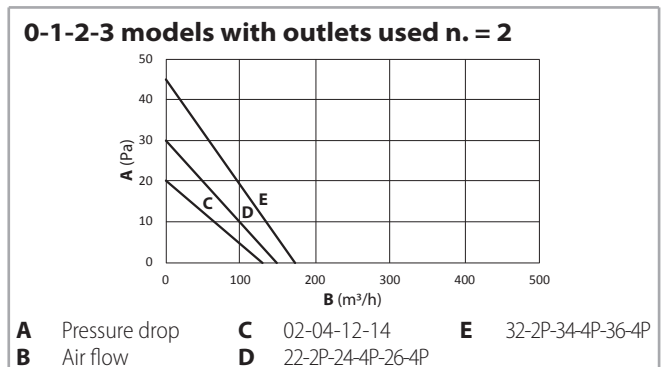
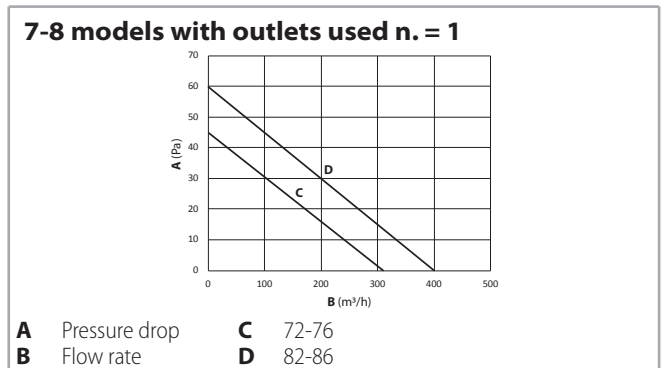
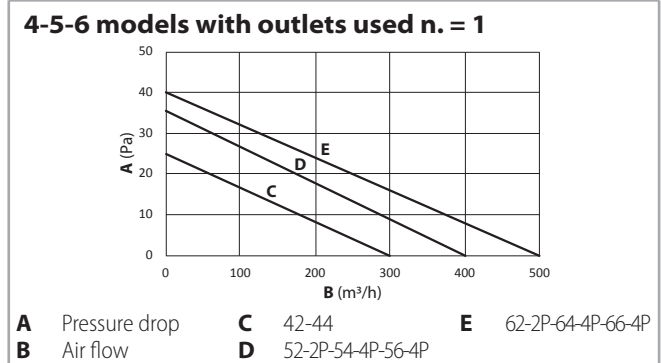
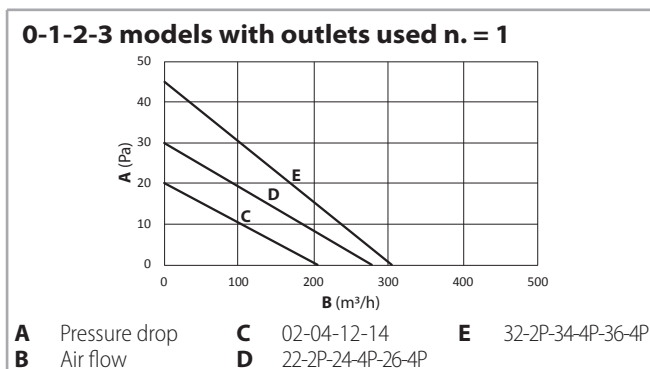

FAK fresh air kit

Not suitable for MCT models with outer casing.

Model	ID	Code
0-1-2-3	FAK 600	9079230
4-5-6	FAK 800	9079231
7-8	FAK 900	9079235

This is used to introduce fresh air into the environment directly through the diffuser.

The kit includes a flow separator to be fitted inside the Cassette, and a circular fitting for connection to the flexible system ducting.

The flow of air is sent directly to just one of the outlet louvers, without passing through the coil. The air flow of fresh air introduced into the environment depends on the inlet static pressure.

The fresh air kit diameters are:

Model		0-1-2-3	4-5-6-7-8
∅ fitting	mm	150	180

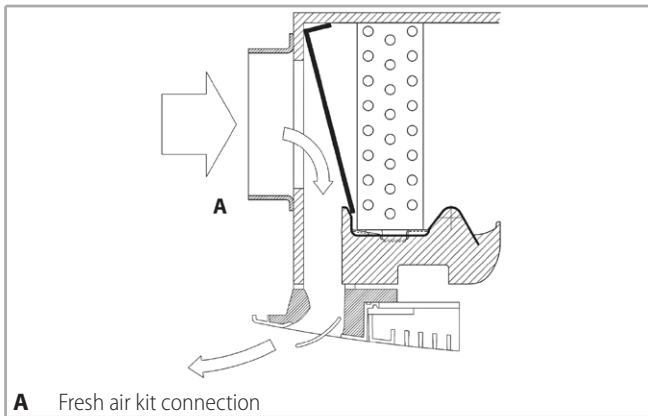

Correlation between flow-rate / Static pressure

Models 0-1-2-3

Flow rate	m ³ /h	80	120	160	200	240
Static pressure	Pa	3	8	15	25	36

Models 4-5-6-7-8

Flow rate	m ³ /h	160	200	300	400	500
Static pressure	Pa	3	8	15	25	36

Units with remote electric board

Factory mounted on standard units **CWS** without MB electronic board.

It can not be fitted on ECM versions.

Model	ID	Code
0-1-2-3-4-5-6	RUS	on request

On request the **CWS** Cassette are available with electric control panel reachable from below and with the electric board that can be placed in a remote position.

In this case the units are supplied with an electronic connecting control panel, fitted to the bottom side on the 4 smallest sizes and to the lateral side on the 3 biggest sizes.

The electronic control panel is connected to the fan motor, to the condensate pump and to the condensate level control.

A 6 m wire is also supplied with integral plug-in connections to connect the unit with the remote electric board that can be installed in a suitable and comfortable position, where the power and system connections can be made easily.

This feature is not available for units with electric heater or infrared remote control.

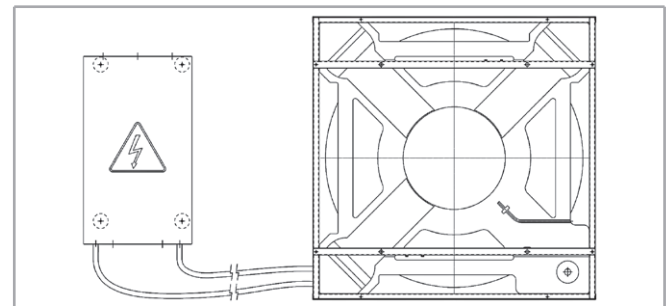

3 ways ON-OFF valves with actuator with interception valve

Valve set with 3 ways ON-OFF valves and with thermoelectric actuator; the set includes connection pipes.

3 ways valves + micrometric lockshield valve connection kit - CWS and CWE

Model	Valve fitted on the unit		Valve not fitted on the unit		Coil	Micrometric lockshield valve connections ø (female)	Kvs m ³ /h	Dp max kPa*
	ID	Code	ID	Code				
CWS 02-2P 12-2P 22-2P 32-2P CWE 1-2P 2-2P 3-2P	3V2T1-3-M	9079510W	3V2T1-3	9079500W	main	1/2"	2,5	50
CWS 42-2P 52-2P 62-2P CWE 4-2P 5-2P	3V2T4-6-M	9079511W	3V2T4-6	9079501W	main	3/4"	4,5	50
CWS 04-4P 14-4P 24-4P 26-4P 34-4P 36-4P CWE 1-4P 2-4P 3-4P	3V4T1-3-M	9079512W	3V4T1-3	9079502W	main	1/2"	2,5	50
					secondary	1/2"	2,5	50
CWS 44-4P 54-4P 56-4P 64-4P 66-4P CWE 4-4P 5-4P	3V4T4-6-M	9079513W	3V4T4-6	9079503W	main	3/4"	4,5	50
					secondary	1/2"	2,5	50

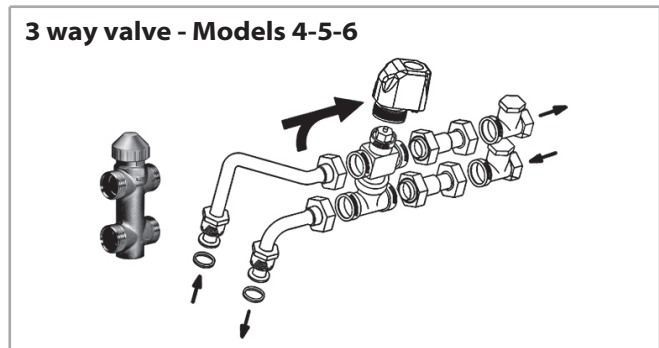
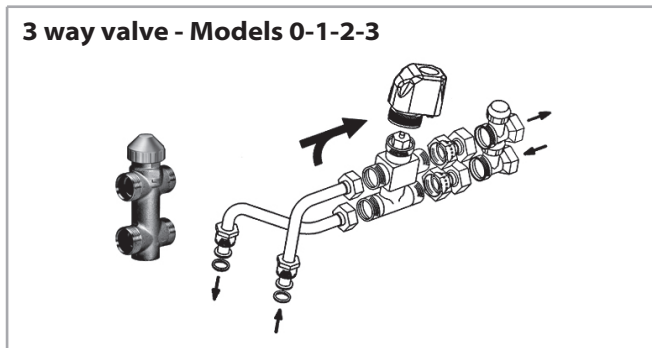

3 ways valves + ball valves connection kit - CWE 7-8

Model	Valve fitted on the unit		Valve not fitted on the unit		Coil	Ball valve connections ø (female)	Kvs m ³ /h	Dp max kPa*
	ID	Code	ID	Code				
72-82	3V2T7-8-M	9079923W	3V2T7-8	9079922W	main	1"	4,5	50
76-86	3V4T7-8-M	9079933W	3V4T7-8	9079932W	main	1"	4,5	50
					secondary	3/4"	2,5	50

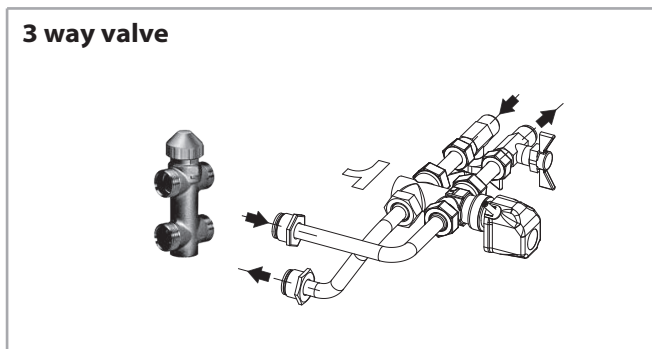

For technical data, operation limits and valves pressure drop, see p. 58

2 ways ON-OFF valves with actuator with interception valve

Valve set with 2 ways ON-OFF valves and with thermoelectric actuator; the set includes connection pipes.

2 ways valves + micrometric lockshield valve connection kit - CWS and CWE

Model	Valve fitted on the unit		Valve not fitted on the unit		Coil	Micrometric lockshield valve connections ø (female)	Kvs m ³ /h	Dp max kPa*
	ID	Code	ID	Code				
CWS 02-2P 12-2P 22-2P 32-2P CWE 1-2P 2-2P 3-2P	2V2T1-3-M	9079515W	2V2T-1-3	9079505W	main	1/2"	2,8	50
CWS 42-2P 52-2P 62-2P CWE 1-2P 2-2P 3-2P	2V2T4-6-M	9079516W	2V2T4-6	9079506W	main	3/4"	5,2	60
CWS 04-4P 14-4P 24-4P 26-4P 34-4P 36-4P CWE 1-4P 2-4P 3-4P	2V4T1-3-M	9079517W	2V4T1-3	9079507W	main	1/2"	2,8	50
					secondary	1/2"	2,8	50
CWS 44-4P 54-4P 56-4P 64-4P 66-4P CWE 4-4P 5-4P	2V4T4-6-M	9079518W	2V4T4-6	9079508W	main	3/4"	5,2	60
					secondary	1/2"	2,8	50

2 way valve - Models 0-1-2-3

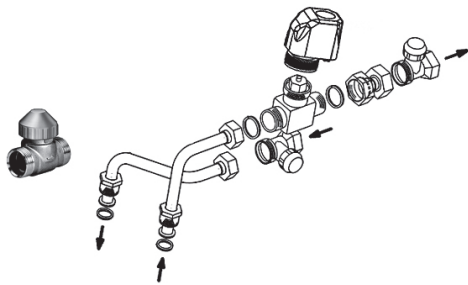

2 way valve - Models 4-5-6

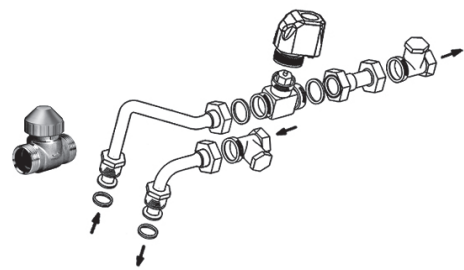

2 ways valves + ball valves connection kit - CWE 7-8

Model	Valve fitted on the unit		Valve not fitted on the unit		Coil	Ball valve connections ø (female)	Kvs m ³ /h	Dp max kPa*
	ID	Code	ID	Code				
72-82	2V2T7-8-M	9079921W	2V2T7-8	9079920W	main	1"	5,2	60
76-86	2V4T7-8	9079931W	2V4T7-8	9079930W	main	1"	5,2	60
					secondary	3/4"	2,8	50

2 way valve

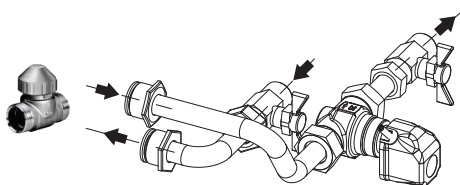

For technical data, operation limits and valves pressure drop, see p. 58

3 ways ON-OFF valves with actuator, without interception valve

Valve set with 3 ways ON-OFF valves and with thermoelectric actuator; the set includes connection pipes.

3 ways valves + simplified connection kit - CWS and CWE

Model	Valve fitted on the unit		Valve not fitted on the unit		Coil	Valve connection ø (male)	Kvs m ³ /h	Dp max kPa*
	ID	Code	ID	Code				
CWS 02-2P 12-2P 22-2P 32-2P CWE 1-2P 2-2P 3-2P	3VS2T1-3-M	9079530W	3VS2T1-3	9079520W	main	3/4"	2,5	50
CWS 42-2P 52-2P 62-2P CWE 4-2P 5-2P	3VS2T4-6-M	9079531W	3VS2T4-6	9079521W	main	1"	4,5	50
CWS 04-4P 14-4P 24-4P 26-4P 34-4P 36-4P CWE 1-4P 2-4P 3-4P	3VS4T1-3-M	9079532W	3VS4T1-3	9079522W	main	3/4"	2,5	50
					secondary	3/4"	2,5	50
CWS 44-4P 54-4P 56-4P 64-4P CWE 4-4P 5-4P	3VS4T4-6-M	9079533W	3VS4T4-6	9079523W	main	1"	4,5	50
					secondary	3/4"	2,5	50

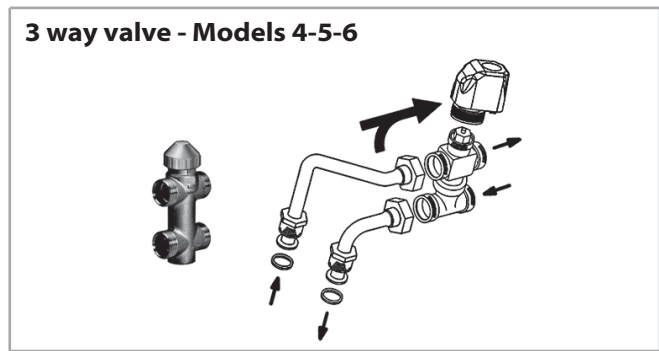
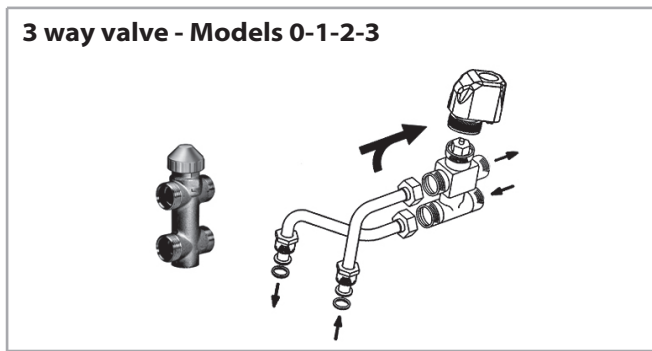

3 ways valves + simplified connection kit - CWE 7-8

Model	Valve fitted on the unit		Valve not fitted on the unit		Coil	Valve connection ø (male)	Kvs m ³ /h	Dp max kPa*
	ID	Code	ID	Code				
72-82	3VS2T7-8-M	9079928W	3VS4T7-8	9079927W	main	1"	4,5	50
76-86	3VS4T7-8-M	9079938W	3VS4T7-8	9079937W	main	1"	4,5	50
					secondary	3/4"	2,5	50

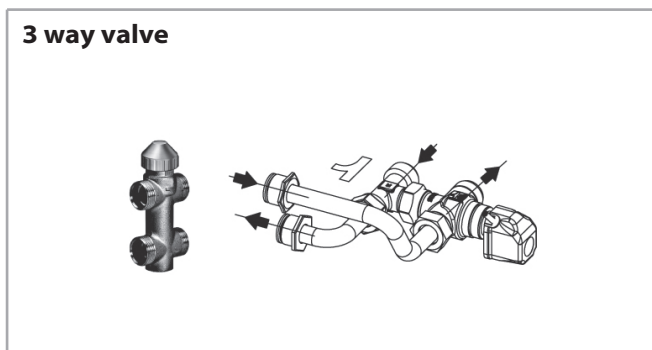

For technical data, operation limits and valves pressure drop, see p. 58

2 ways ON-OFF valves with actuator, without interception valve

Valve set with 2 ways ON-OFF valves and with thermoelectric actuator; the set includes connection pipes.

2 ways valves + simplified connection kit - CWS and CWE

Model	Valve fitted on the unit		Valve not fitted on the unit		Coil	Valve connection ø (male)	Kvs m ³ /h	Dp max kPa*
	ID	Code	ID	Code				
CWS 02-2P 12-2P 22-2P 32-2P CWE 1-2P 2-2P 3-2P	2VS2T1-3-M	9079535W	3VS2T1-3	9079525W	main	3/4"	2,8	50
CWS 42-2P 52-2P 62-2P CWE 4-2P 5-2P	2VS2T4-6-M	9079536W	2VS2T4-6	9079526W	main	1"	5,2	60
CWS 04-4P 14-4P 24-4P 26-4P 34-4P 36-4P CWE 1-4P 2-4P 3-4P	2VS4T1-3-M	9079537W	3VS4T1-3	9079527W	main	3/4"	2,8	50
					secondary	3/4"	2,8	50
CWS 44-4P 54-4P 56-4P 64-4P 66-4P CWE 4-4P 5-4P	2VS4T4-6-M	9079538W	3VS4T4-6	9079528W	main	1"	5,2	60
					secondary	3/4"	2,8	50

2 way valve - Models 0-1-2-3

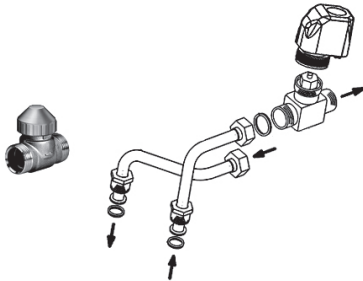

2 way valve - Models 4-5-6

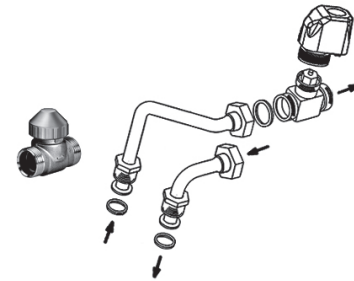

2 ways valves + simplified connection kit - CWE 7-8

Model	Valve fitted on the unit		Valve not fitted on the unit		Coil	Valve connection ø (male)	Kvs m ³ /h	Dp max kPa*
	ID	Code	ID	Code				
72-82	2VS2T7-8-M	9079926W	2VS2T7-8	9079925W	main	1"	5,2	60
76-86	2VS2T7-8-M	9079936W	2VS4T7-8	9079935W	main	1"	5,2	60
					secondary	3/4"	2,8	50

2 way valve

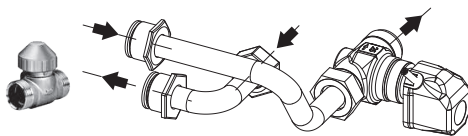

For technical data, operation limits and valves pressure drop, see p. 58

Valves technical data and operation limits

Description	UoM	Value
Max. working pressure	bars	16
Max. ambient temperature	°C	50
Max. water temperature	°C	110
Power supply	V-Hz	230-50/60
Rating	VA	2,5
Protection		IP 44
Travel time	min	ca. 3
Max. glycol content of water	%	50

Note: The maximum pressure drop across the fully open valve should not exceed 25 kPa for cooling operation and 15 kPa for heating operation.

Valves pressure drop

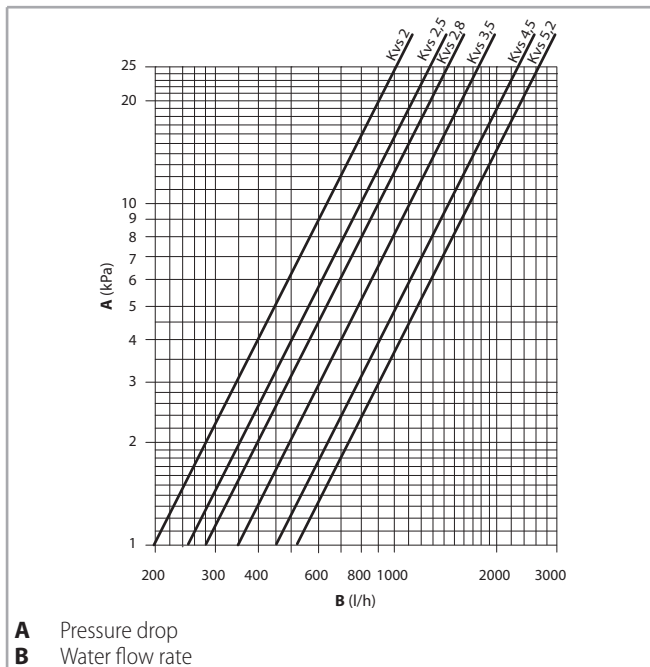

Balance valve with actuator

CWE 7-8 excluded.

Balancing valves independent from the system pressure.

- The balancing valve and a combined 2 way valve allow the regulation of the water flow value autonomously, regardless of the system pressure, and the control of the flow by using an ON/OFF electro-thermal actuator.
- The balancing valve allows you to balance the hydraulic system by supplying the required water flow, for each fan-coil, and to maintain it even under partial load conditions.
- A graduated ring nut placed under the valve allows you to set the flow rate value and also allows direct reading of the set value.



Valve operation logic

- "p1" the valve inlet pressure.
- "p3" the outlet pressure.
- "p2" the diaphragm activation pressure, which allows differential pressure "p2" – "p3" to be maintained at a constant value, in order to guarantee the water to flow at the set value.

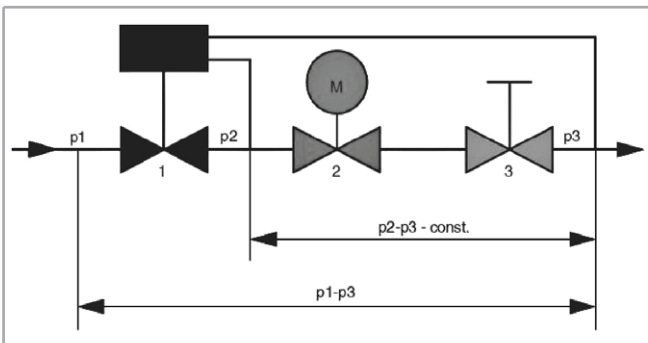

The minimum differential pressure "p1" – "p3", required to guarantee the correct value of the set water flow rate, is indicated in the diagrams on p. 60.

This is an essential factor to size the system pressure drop and pump pressure head.

The flow rate is kept at a constant value only if the valve pressure drop is higher than the indicated value.

Minimum operating differential pressure

The minimum differential pressure and the balancing valve pressure drop must be considered to size the system pumps.

The flow rate remains stable only if the water side pressure drop will be more than the one shown in the p. 60 diagrams.

The following diagram shows an example of the flow rate trend according to the pressure drop and calibration required.

Example DN 15 Model

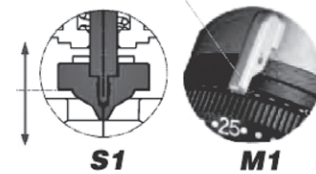
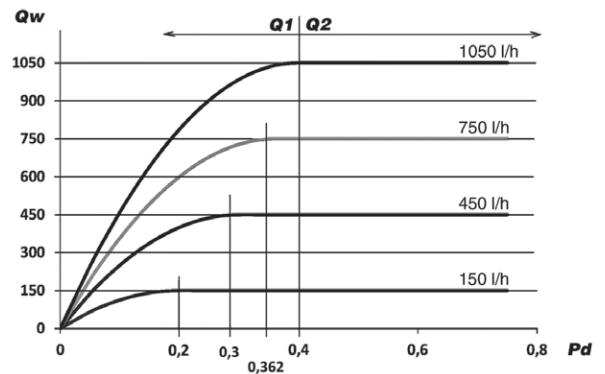

Qw = Water flow rate
 Pd = Min. differential pressure "p1" - "p3" (bar)
 Q1 = Area with inconstant water flow
 Q2 = Area with constant water flow
 S1 = Position of the adjustment valve plunger
 M1 = Position of the knob

The valve upstream-downstream minimum differential pressure ("p1" - "p3"), which depends on the valve calibration value, must be exceeded to access the constant flow rate field.

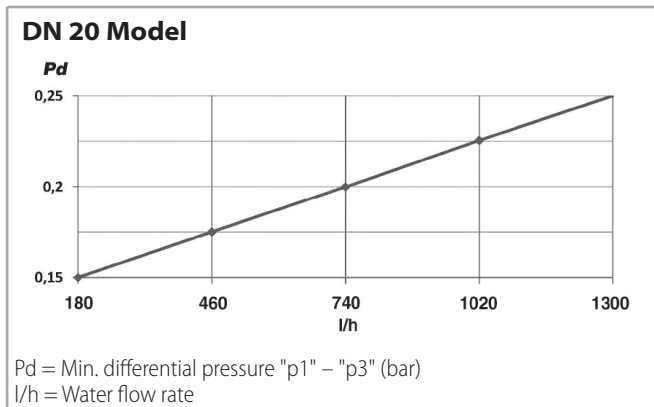
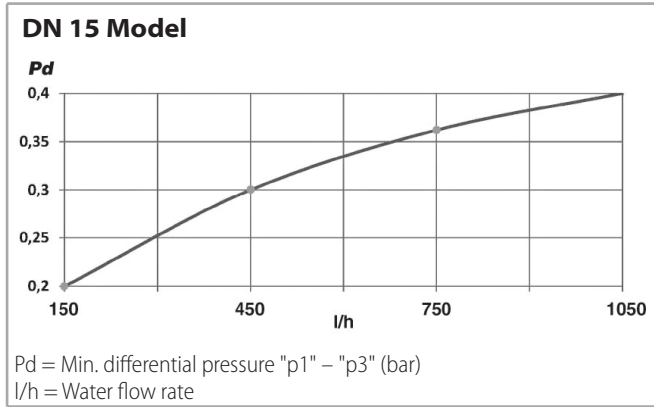

E.g., when sizing the system pump, in which the DN 15 valves will be installed and in which 450 l/h are constantly required for each device, consider a useful pressure of 0.3 bar (to compensate the pressure drop of the valve) for each balancing valve. Therefore, the pressure drop values produced by the system balancing valves must be summed and the pump must be sized to produce a pressure equal to or greater than the value obtained previously.

Benefits

- Reduced dimensions.
- Easy installation on 2 or 4 pipe devices.
- Pre-regulation of the nominal value set even with installed actuator.
- Easy display of the nominal value set. Nominal values are indicated in 10 l/h without any conversion.
- Guarantee of constant flow rate set even with partial loads.
- Pre-regulation can be blocked and leaded with the locking ring.

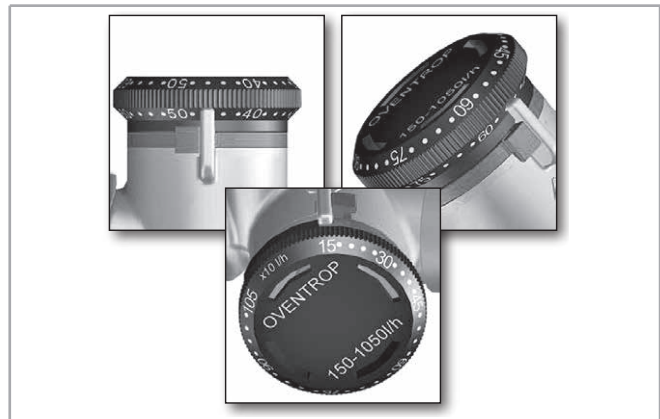

Technical specifications

DN model	Flow rate range (l/h)	Kvs
DN 15	150 - 1050	1,8
DN 20	180 - 1300	2,5

Operation limits of the balancing valves

- Maximum operating temperature: 120 °C
- Highest working pressure: 16 bar
- Maximum % of water/glycol mixture: 50%
- Minimum operating temperature: -10 °C
- Maximum differential pressure: 4 bar

Balancing valves for main coil

2 way valve for main coil and assembly kit.

The valve is supplied equipped with 230 Volt electro-thermal actuator for the ON/OFF control.

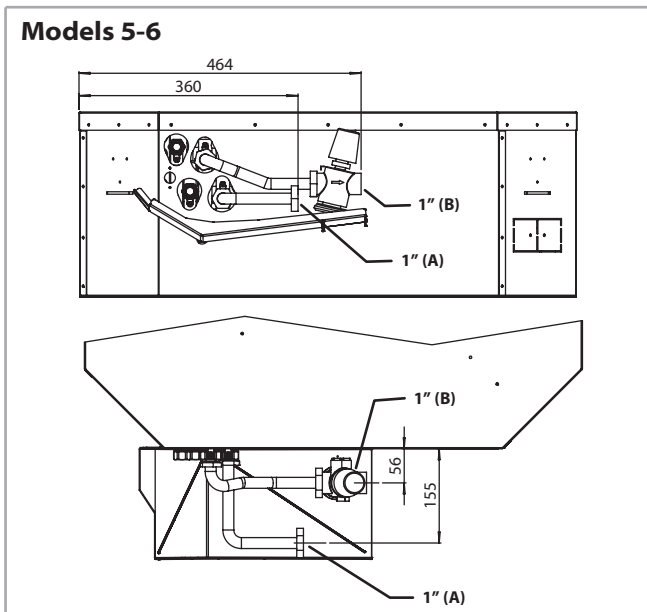
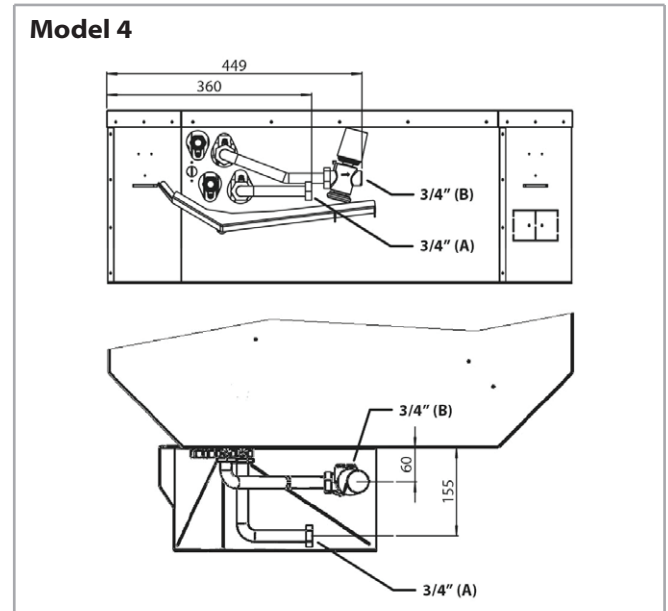
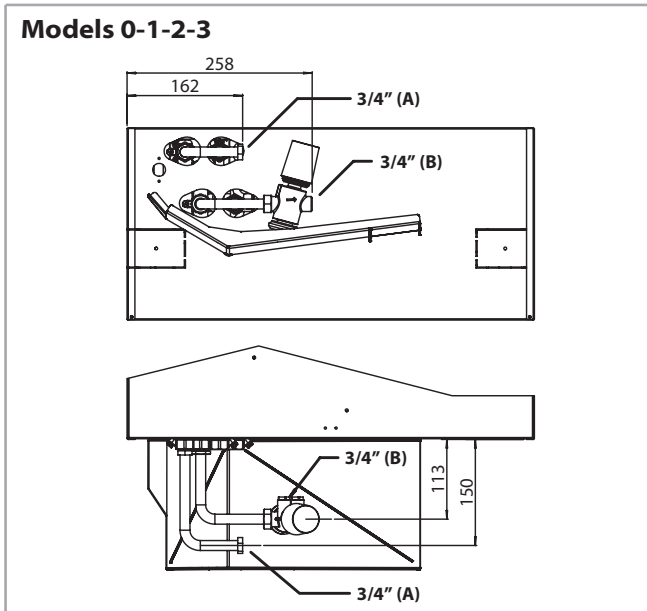

(A) = Water inlet - Female connection

(B) = Water outlet - Male connection

Model	DN	(Ø)	Qwr	Valve fitted on the unit		Valve not fitted on the unit	
				ID	Code	ID	Code
0-1-2-3	15	3/4"	150-1050	V20VSK6BPM 150-1050	9079771	V20VSK6BPS 150-1050	9079761
4				V20VSK8BPM 150-1050	9079791	V20VSK8BPS 150-1050	9079781
5-6	20	1"	180-1300	V20VSK8BPM 180-1300	9079792	V20VSK8BPS 180-1300	9079782

Balancing valves for main and additional coil

2 way valve for main and additional coil and assembly kit.

The valve is supplied equipped with 230 Volt electro-thermal actuator for the ON/OFF control.

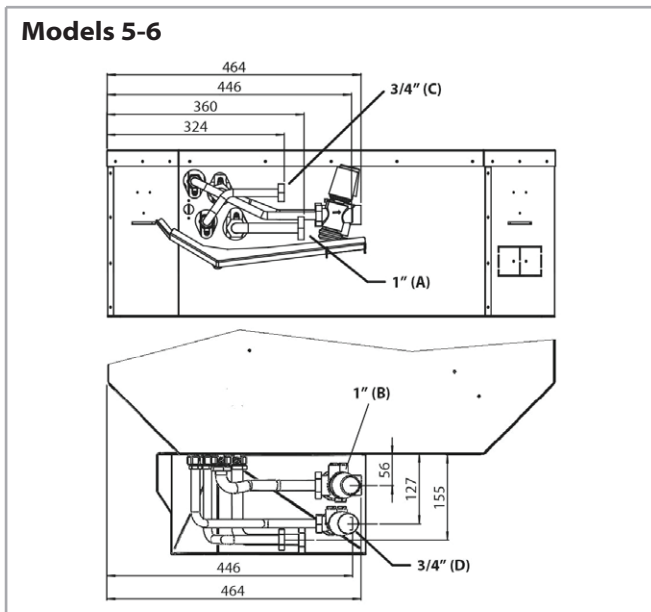
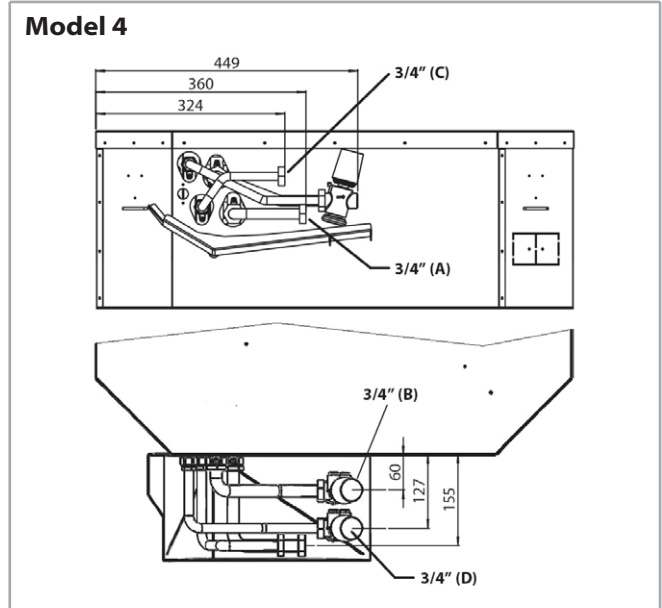
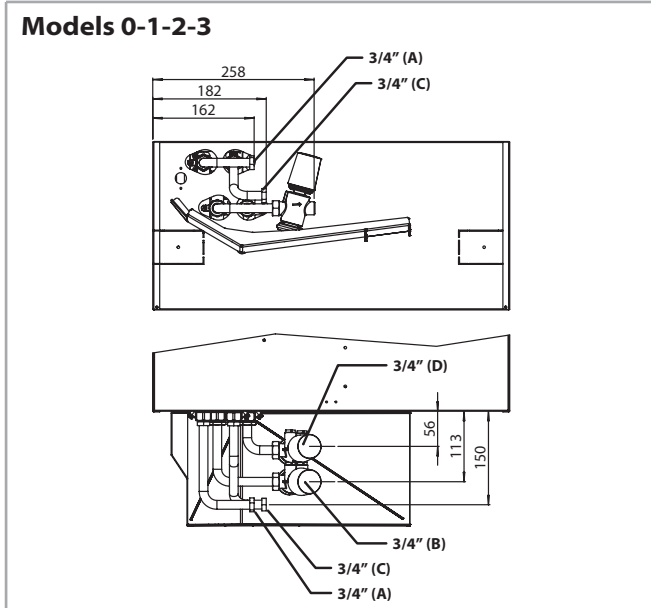

- (A) = Water inlet (main coil) - Female connection
- (B) = Water outlet (main coil) - Male connection
- (C) = Water inlet (additional coil) - Female connection
- (D) = Water outlet (additional coil) - Male connection

Model	DN	(Ø)	Qwr	Main coil			
				Valve fitted on the unit		Valve not fitted on the unit	
				ID	Code	ID	Code
0-1-2-3	15	3/4"	150-1050	V2OVSK6BPM 150-1050	9079771	V2OVSK6BPS 150-1050	9079761
4				V2OVSK8BPM 150-1050	9079791	V2OVSK8BPS 150-1050	9079781
5-6	20	1"	180-1300	V2OVSK8BPM 180-1300	9079792	V2OVSK8BPS 180-1300	9079782

Model	DN	(Ø)	Qwr	Additional coil			
				Valve fitted on the unit		Valve not fitted on the unit	
				ID	Code	ID	Code
0-1-2-3	15	3/4"	150-1050	V2OVSK6BAM 150-1050	9079773	V2OVSK6BAS 150-1050	9079763
4-5-6				V2OVSK8BAM 150-1050	9079793	V2OVSK8BAS 150-1050	9079783

MCT casing

Model	ID	Code
0-1-2-3	MCT 600	9079240
4-5-6	MCT 800	9079250
7-8	MCT 900	9079886

The MCT version has been designed for all environments where false ceilings are not featured or cannot be constructed.

The casing fits perfectly to the air intake and outlet diffuser, maintaining the appealing design that defines the Cassette serie.

The water fittings can be turned to point upwards.

The MCT series includes 9 models, with an installation height of up to 5 m, thanks to the highly flexible adjustment of the air distribution louvers.

All the technical specifications described on the previous pages remain the same, while keeping in mind that:

- the MCT series features one coil only (2 pipe systems)
- there is no possibility of fresh air intake
- there is no possibility of additional electric heater

The MCT version features a special casing, in COOL GREY 1C colour, delivered in separate packaging; this must only be fitted after having installed the unit and completed the water and electrical connections.

Warning: the electrical and water connections must enter the unit from above and must not interfere with the casing.

2 pipes CWS / CWE models



2 pipes CWE 7-8 models



Dimension and weight

MCT 600

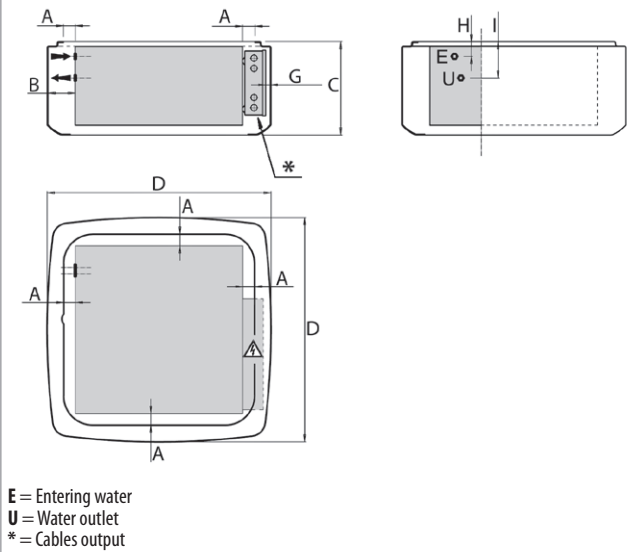

MCT 800-900

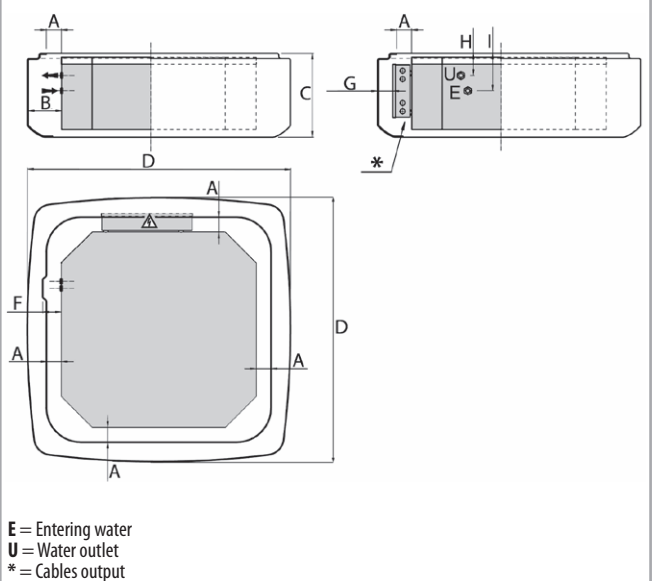

Model		MCT 600	MCT 800	MCT 900
A	mm	40	62	53
B	mm	93	140	126
C	mm	320	350	350
D	mm	768	1089	1125
F	mm	-	78	69
G	mm	15 max	65 max	33 max
H	mm	51	94	94
I	mm	125	158	158
Weight with packaging	kg	5	10,5	11
Weight without packaging	kg	7,5	13,5	14

Assembly diagram

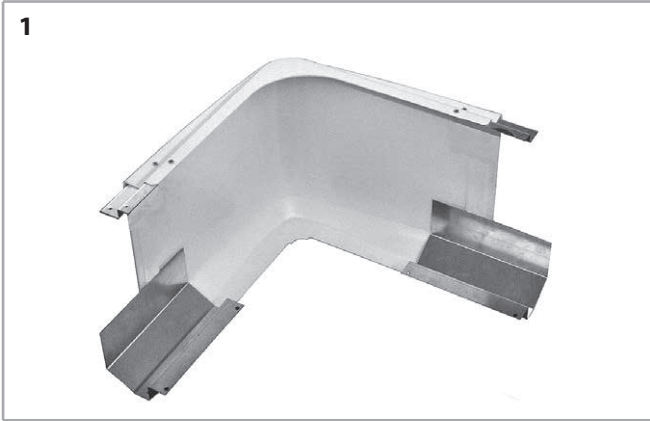

Components of the casing

The casing includes the following elements:

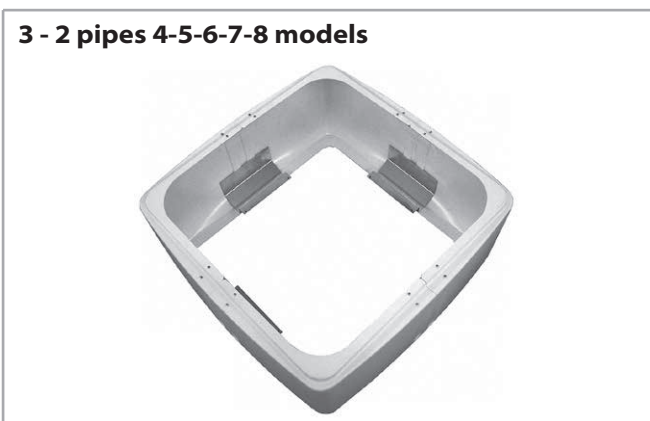
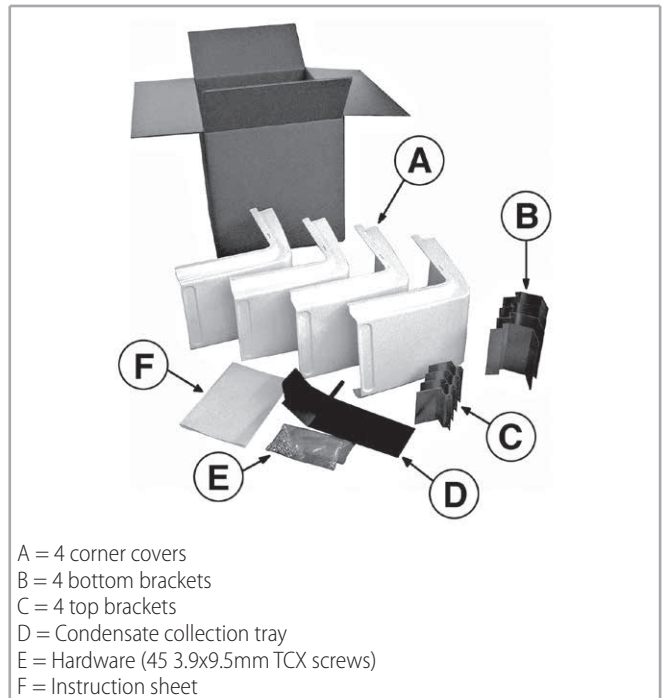

Valves kit

Model	Kvs m ³ /h	Dp max kPa*	Micrometric lockshield valve connections (female) Ø	Ball valve connections (female) Ø	ID	Code
MCT 600	2,5	50	3/4"	-	3V2T1-3MCT	9079155
MCT 800	4,5		1"		3V2T4-6MCT	9079221
MCT 900			3/4"	1"	3V2T7-8MCT	9079945W

* maximum pressure difference for valve to close

The valve fittings allow the water pipes to be connected from above.

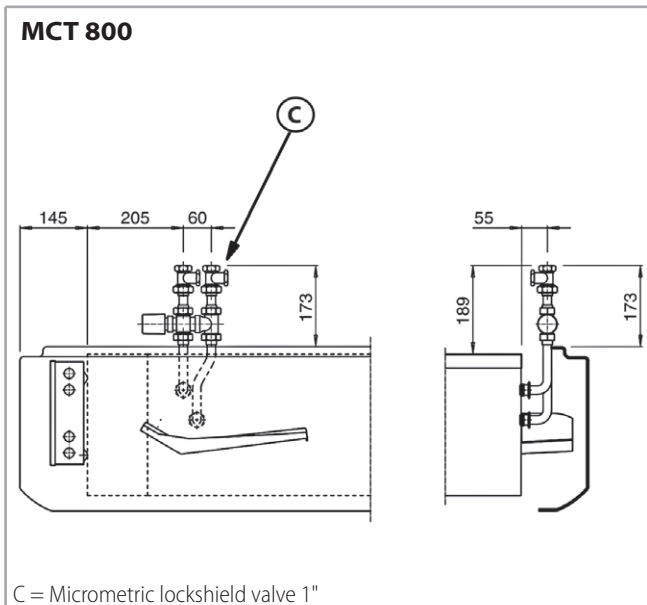
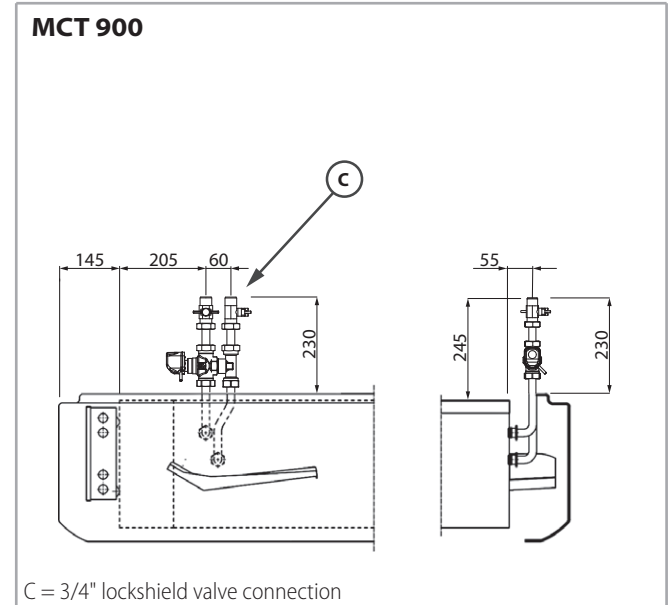
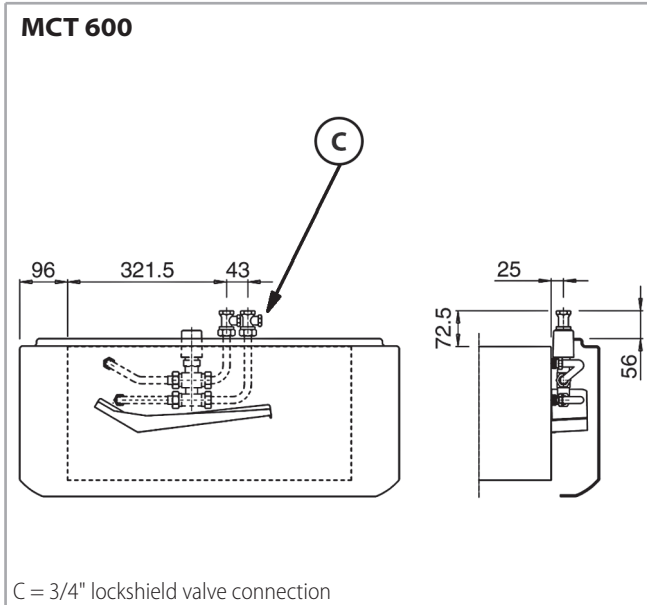

ELECTRONIC ELECTROSTATIC FILTER

CWE 7-8 excluded.

Cassette fan coil units, **CWS** and **CWE** series (except CWE 7-8), can be equipped with the innovative plate type electrostatic filter, combining air treatment and purifying in a single product.

The electronic filter is patented and certified according to Standard UNI 11254 and UNI EN ISO 16890 Class A+ (Eurovent).

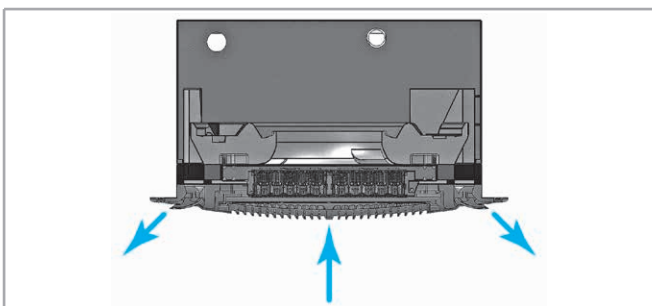
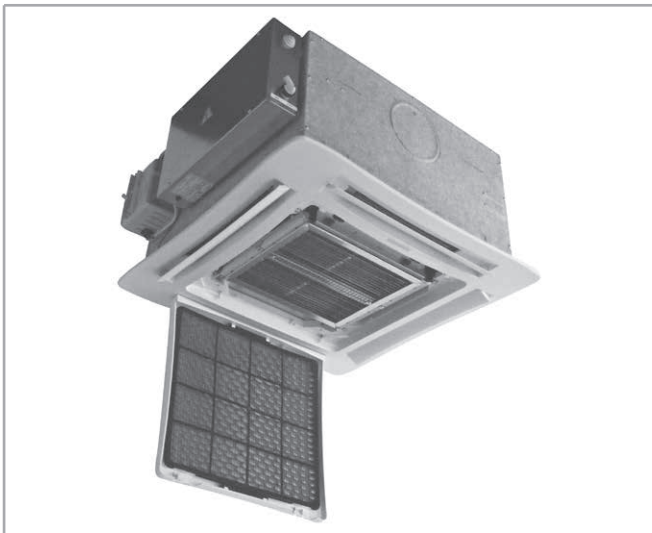
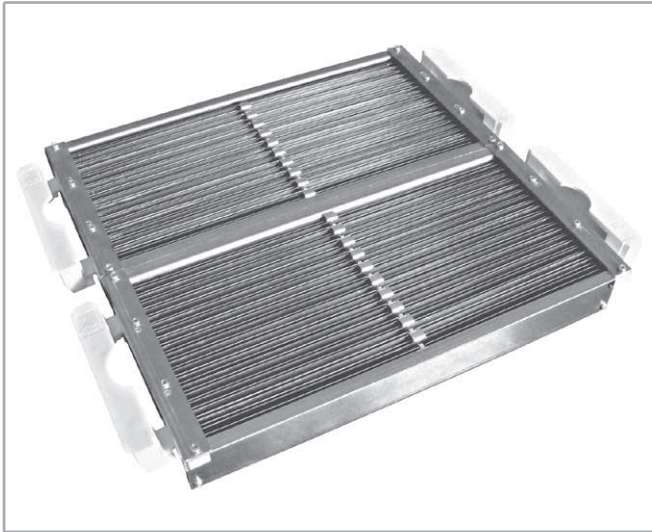

Operating principle of the electrostatic filter

When the polluted air goes through the mechanical pre-filter the particles $> 50 \mu\text{m}$ are eliminated (powder, insects, etc).

Then the smallest particles ($50 \div 0.01 \mu\text{m}$) are exposed to an intensive ionizing field and are polarized (B - B Phase).

The charged particles passing through the second filter section, are pushed back by the anode and attracted to the collection surfaces by a strong, induced magnetic field (C - C Phase).

The air which leaves the unit is free from polluting particles.

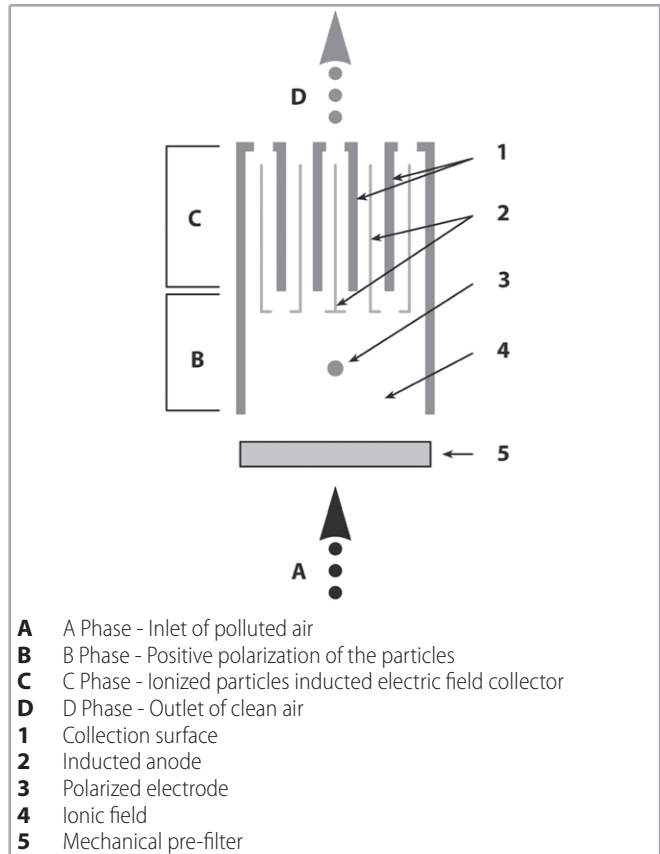

Dimensions

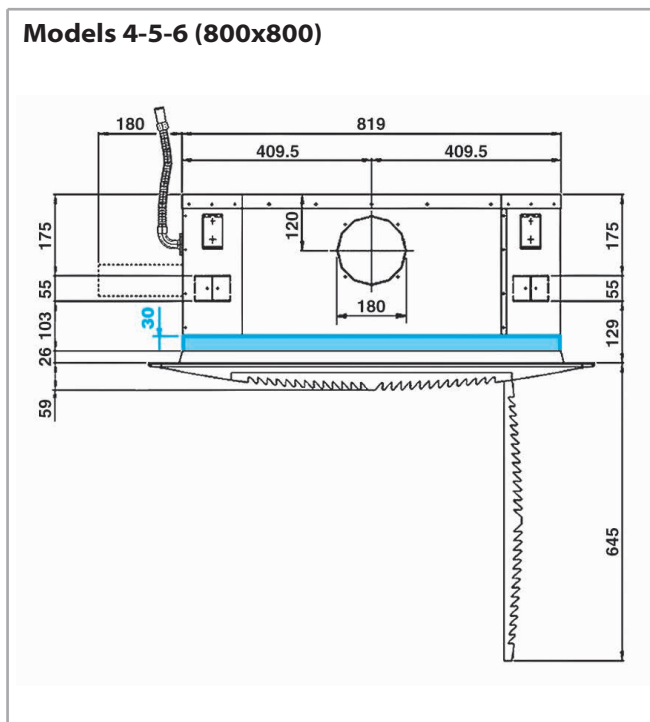
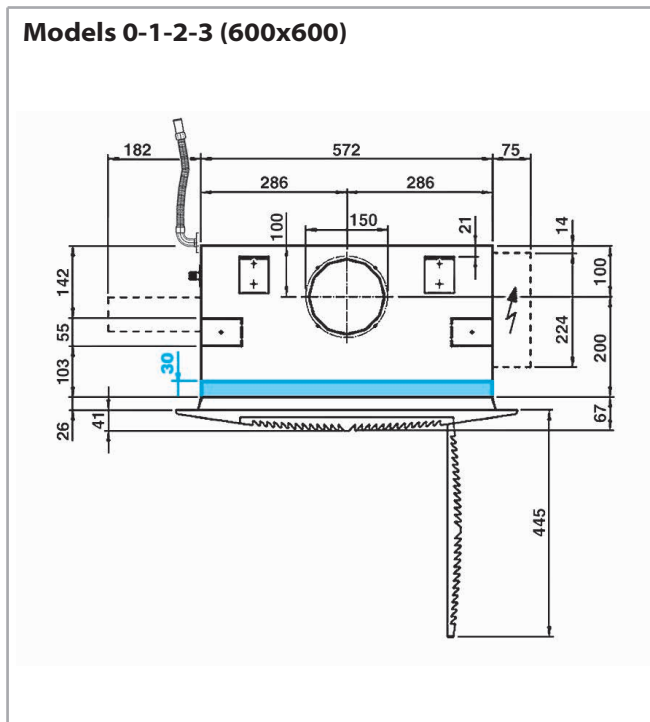

Indoor air quality (IAQ)

The expression Indoor Air Quality (IAQ) covers all the procedures and methodologies used to improve the quality of the air we breathe in the places where we live and work, from all points of view, from temperature to cleanliness, to relative humidity, etc. (UNI EN 16798-1 / 3).

Thanks to its new patented electronic filter, the

electrostatic filter totally eliminates the pollutants present in the air, including tobacco smoke, dust (PM10, PM2.5, PM1), fibres, microbiological substances such as bacteria, fungi, virus, etc., which are harmful to human health (source: WHO 2009).

Purifying the air means not only greater well-being, but also energy saving, as the fresh air changes are significantly reduced (indeed it is enough to supply just the quantity of air required to reduce the gaseous pollutants).

Moreover, according to the new EN UNI 16798, the re-circulated air of the unit can be considered as fresh air, because it is filtered with the same efficiency (ePMx), to be added to the minimum requirements (0,5 ls/ m² or 4 lt/pers. in accordance with WHO).

The positioning of the electronic filter allows simple and effective maintenance and, as it is easy to wash, its working life is practically unlimited.

The modularity of the filter components and their ease of mounting make the system extremely competitive in terms of cost and energy consumption (A+ class) if compared with other types of filters present on the market.

In spring and autumn, if air conditioning/heating is not required, the appliance acts simply as an air purifier.

Standards and legislation

The ambient condition is acceptable when:

- Microclimatic parameters are normal
- 80% of people are satisfied by the quality of air
- Specific internal contaminants are not in harmful concentrations

"Guidelines for the protection and promotion of health in confined areas O.G. No. 276 dated 27 Nov 01 ordinary supplement no. 252"

The method for obtaining the air quality required in confined areas and thus succeeding in ensuring that the contaminants present are in concentrations less than those considered dangerous to health are:

- **Prescriptive approach:** ventilation of the internal area using only properly filtered fresh air (SUPx), in the quantity and quality needed to dilute the internal contaminants in order to reach the required maximum acceptable concentration values (see WHO limits).
- **Performant approach:** ventilation with fresh air and recirculated air from the same area, both properly filtered, in the quantity and quality needed to dilute the internal contaminants in order to reach the required maximum acceptable concentration values (see WHO limits).

The quantity and quality of recirculated air and fresh air

to supply is better specified in the prescriptive approach of UNI EN 16798-1 (annex A national legislative) and UNI EN 16798-3.

The flow rate derives from a binomial equation that joins a proportion per surface (qp.s) (L/sec/m²), that can change according to the internal emission of the contaminants (3 classes: very low polluting, low polluting,

non low polluting) and a proportion per person (qp.p) (L/sec/pers.).

Tot. flow rate = (qp.s x m²) + (qp.p x N°pers.)

The table here below shows partially an example of the values:

Prescriptive Method

Ambients	UNI EN 16798-1 (annex A national legislative)											
	Flow rate per person (l/sec/pers.)			Flow rate per surface (l/sec/m ²) Very low polluting			Flow rate per surface (l/sec/m ²) Low polluting			Flow rate per surface (l/sec/m ²) Non low polluting		
	1	2	3	1	2	3	1	2	3	1	2	3
Offices	8,50	7,50	5,50	0,25	0,20	0,15	0,50	0,40	0,30	1,00	0,80	0,60
Hospital room	11,50	10,00	8,70	0,25	0,20	0,15	0,50	0,40	0,30	1,00	0,80	0,60
Restaurants	8,75	7,00	5,25	0,63	0,50	0,38	1,25	1,00	0,75	3,00	2,00	1,50
Shops	8,75	7,00	5,25	0,50	0,40	0,30	1,00	0,80	0,60	2,00	1,60	1,20
Schools	7,50	6,00	4,50	0,32	0,25	0,19	0,63	0,50	0,38	1,26	1,00	0,76

Performant Method

UNI EN 16798-1		
Identification and quantification of the reference pollutant (PM or gas)		
Concentration Limit	Minimum fresh air l.s. person	Quantity of recirculated air provided that it is filtered like fresh air
WHO publicized values and legislative acts expressed in µg/m ³ , PPM, ecc.	5 - 6	The volume of air to be considered is based on the internal production and the imposed concentration limits in the confined area

Identification and quantification of the reference pollutant (PMx)		
Concentration Limit	Minimum fresh air l.s. person	Quantity of recirculated air provided that it is filtered like fresh air
WHO publicized values and legislative acts expressed in µg/m ³ , PPM, ecc.	The minimum volume of air input varies based on the intended use of the confined area	The volume of air to be considered is based on the internal production and the imposed concentration limits in the confined area

Fresh air flow rates according to the performant approach

UNI EN 16798-1 and UNI EN 16798-3 Standards

The example reproduced at the bottom of the page shows how, with adequate air filtering, it is possible to decrease considerably the quantity of fresh air to be brought into the environment (up to 3-4 times less):

the thermal energy dissipated due to ventilation is in fact in direct proportion to the number of air changes, as indicated in the following equation:

Qv = ΔT • (R / 3600) • D • C • Vol.

Qv = Thermal energy lost for ventilation - Watt

ΔT = Indoor-Outdoor difference (T) - °C

R = A.C.H.

D = Air density - Kg/m³

C = Specific air heat - J/Kg-°C

Vol = Room size - m³

Note: www.tecnicabontempi.it for the simplified "IAQ software" performance rating

Main components

The filtering element consists of two sections: the first consists of electrodes and insulating elements, forming a self-supporting ionising frame, while the second consists of special light aluminium fins (collector).

All electrical connections are made during production. The installation of the Cassette fan coil unit incorporating the electronic filter is therefore similar to that of a normal unit: the only difference is the installation height, for which the filter dimensions must be taken into account (30 mm).

The electronic electrostatic filters can not be used with the electric heater.

Active plate type electronic filter

The filtering element consists of two sections: the first consists of electrodes and insulating elements, forming a self-supporting ionising frame, while the second consists of special light aluminium fins (collector).

The two sections are installed above the return air grille to make the extraction and maintenance of the filter easier.

Accessibility to sections to be cleaned is ensured by easy-open plastic closures.

The collector can be cleaned by washing with water and ordinary detergents or steam jets (please consult the maintenance manual for further details).

PCB (electronic board)

Controls and regulates all functions of the electrostatic filter.

It is appropriately protected against any operating defects of the electrostatic filter.

It supplies a constant voltage to the electrodes when the mains supply voltage varies ($\pm 15\%$).

The supply transformer is constructed with its primary and secondary coils physically separated and wound onto separate cores.

The energy consumption of the filter group is 25 W (to which the electrical consumption of the Cassette must be added).

Control and regulation commands

Units with electronic electrostatic filter can be controlled and regulated by the series of IAQ controls that are already provided for FxAS fan coils units.

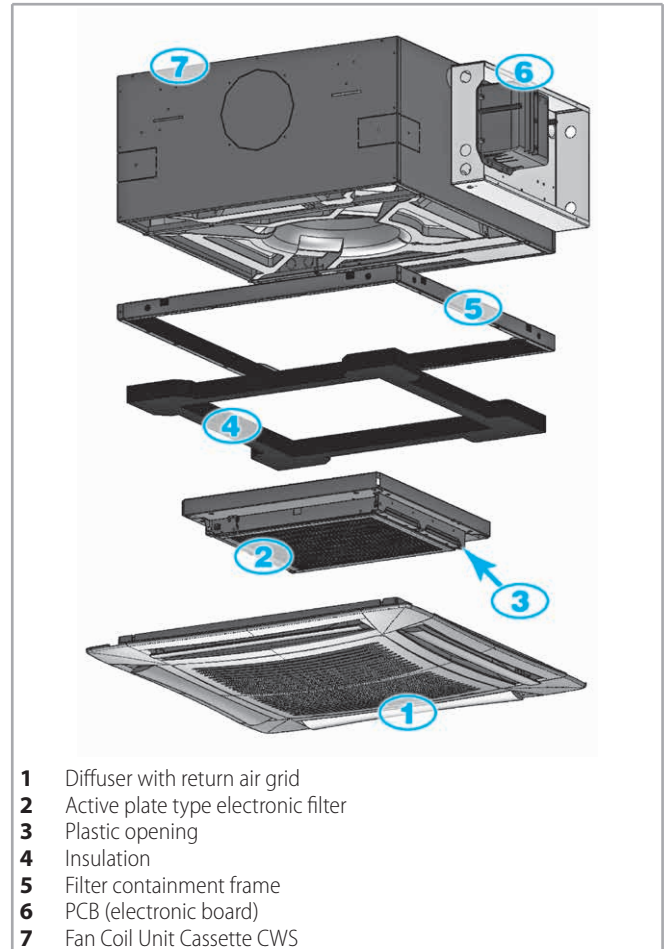

- 1 Diffuser with return air grid
- 2 Active plate type electronic filter
- 3 Plastic opening
- 4 Insulation
- 5 Filter containment frame
- 6 PCB (electronic board)
- 7 Fan Coil Unit Cassette CWS

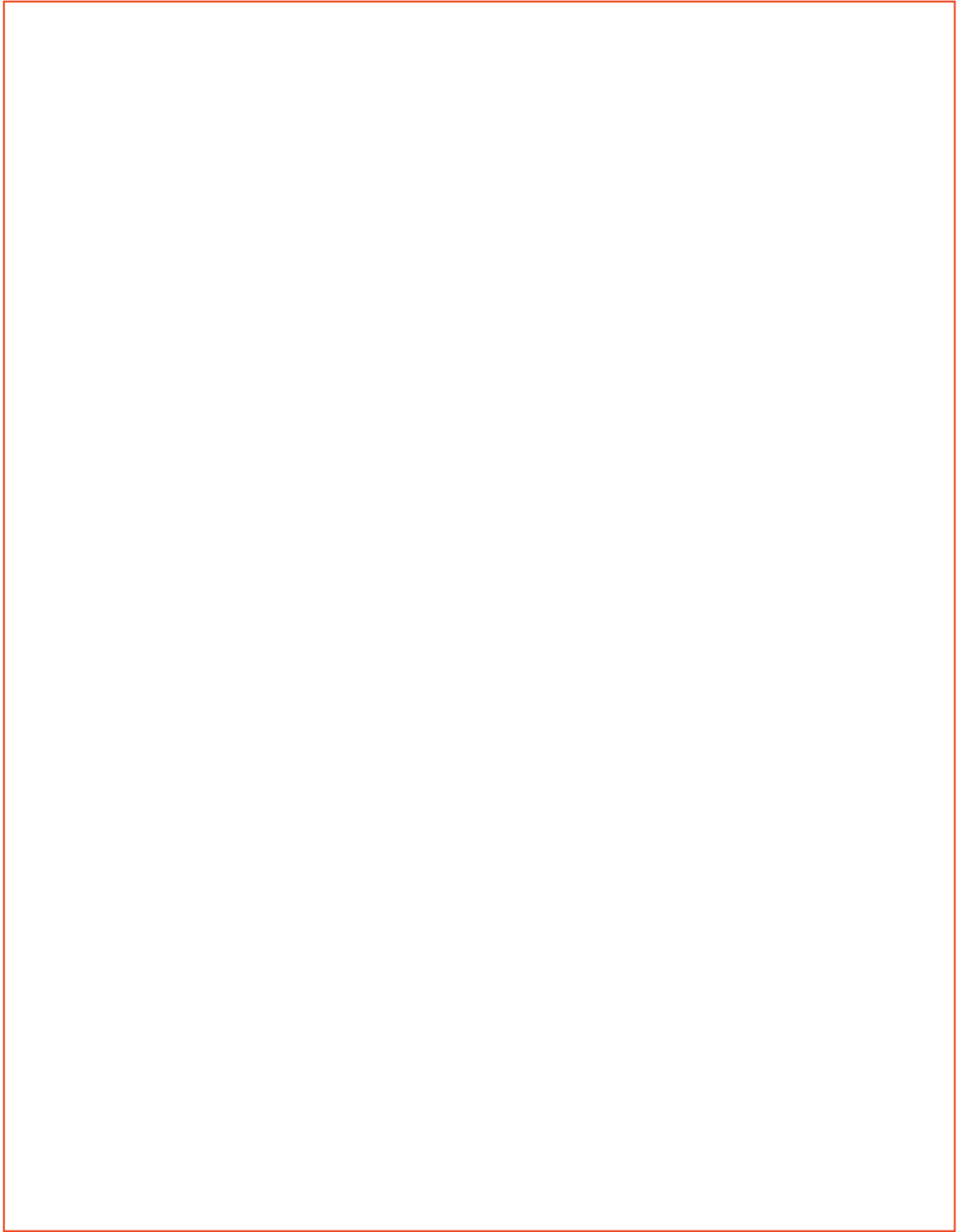

The descriptions and illustrations provided in this publication are not binding: **Trane** reserves the right, whilst maintaining the essential characteristics of the types described and illustrated, to make, at any time, without the requirement to promptly update this piece of literature, any changes that it considers useful for the purpose of improvement or for any other manufacturing or commercial requirements.



TRANE
TECHNOLOGIES

Trane - by Trane Technologies (NYSE: TT), a global climate innovator - creates comfortable, energy efficient indoor environments for commercial and residential applications. For more information, please visit www.trane.eu or www.tranetechnologies.com

Trane has a policy of continuous product and product data improvement and reserves the right to change design and specifications without notice. We are committed to using environmentally conscious print practices. Confidential and proprietary Trane information.