

HJEM 20 M4 (265201103)

GENERAL DATA



SQUARE WALL PLATE FAN

MANUFACTURING FEATURES

- Square plate made of galvanized steel sheet.
- Aluminium sheet impeller.
- Supplied with motor support and protection guard according to the UNE-EN 294 standard.
- Shaded-pole asynchronous motor, rated Class F isolation and IP-42.

APPLICATIONS

Designed for wall assembly, they are suitable for:

- Air renewal in all kind of closed environments.
- Maximum working temperature: 50°C.

PERFORMANCE CURVE

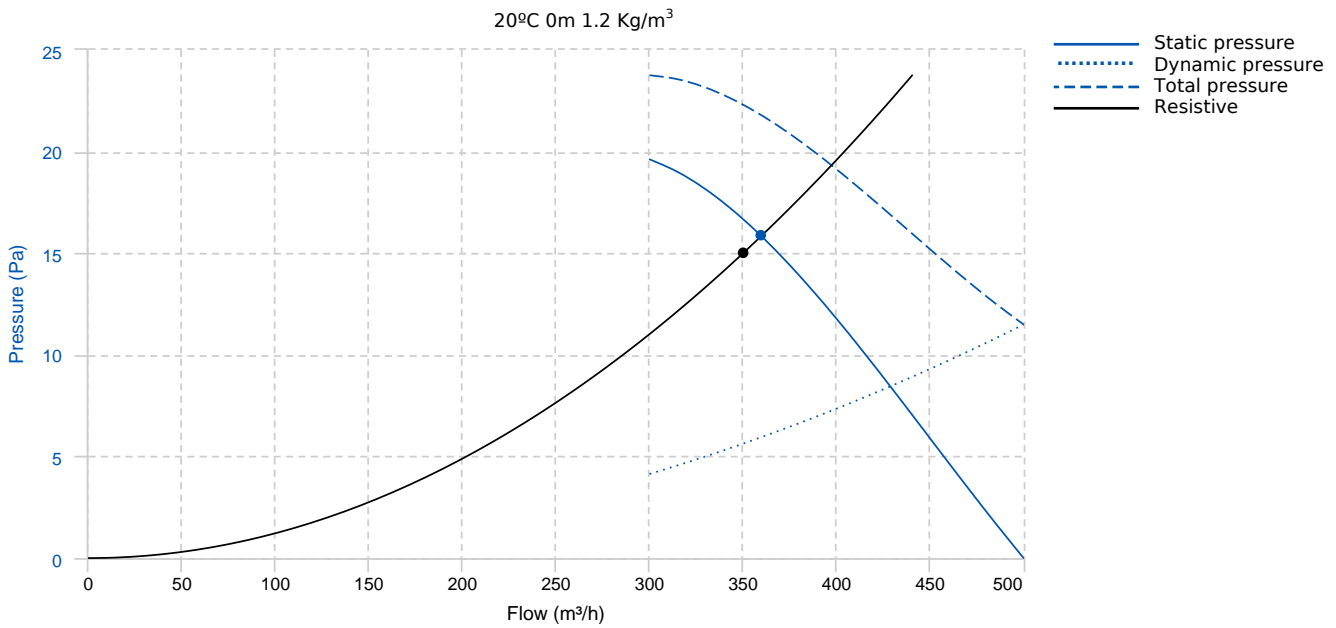

Design point

Flow (m³/h)	350	Pressure (Pa)	15
-------------	-----	---------------	----

Service point							
T.max (°C)	50	Q (m³/h)	359.7	Ps (Pa)	15.84	Pd (Pa)	5.95
Pt (Pa)	21.79	Speed (m/s)	3.15	Fan total efficiency	6.17	Pabs (kW) 1.2 kg/m³	0.04
SFP (W/l/s) 1.2 kg/m³	0.35						

TECHNICAL DATA

Fan					
RPM	1300	Approx. weight	1.5 kg	Max. Flow	510 m³/h
Motor					
Power	0,005 kW	RPM	1300	I max. (230V)	0,21 A

ACOUSTIC DATA

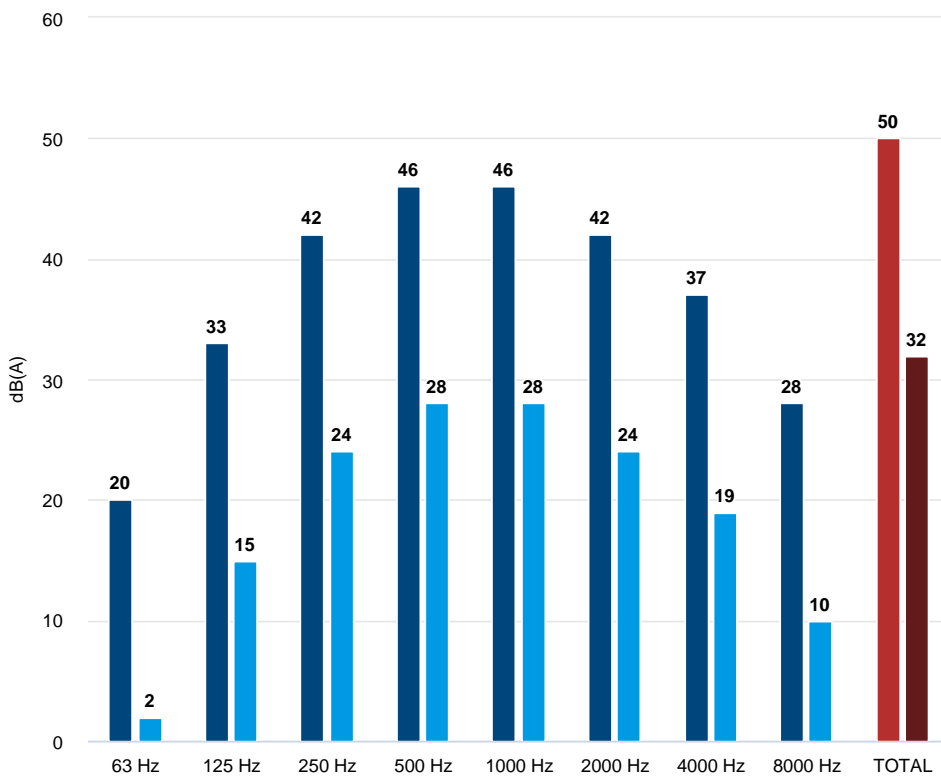

Sound power	
63 Hz	20
125 Hz	33
250 Hz	42
500 Hz	46
1000 Hz	46
2000 Hz	42
4000 Hz	37
8000 Hz	28
TOTAL	50

Sound pressure 3m (in) Q=2	
63 Hz	2
125 Hz	15
250 Hz	24
500 Hz	28
1000 Hz	28
2000 Hz	24
4000 Hz	19
8000 Hz	10
TOTAL	32

DIMENSIONS

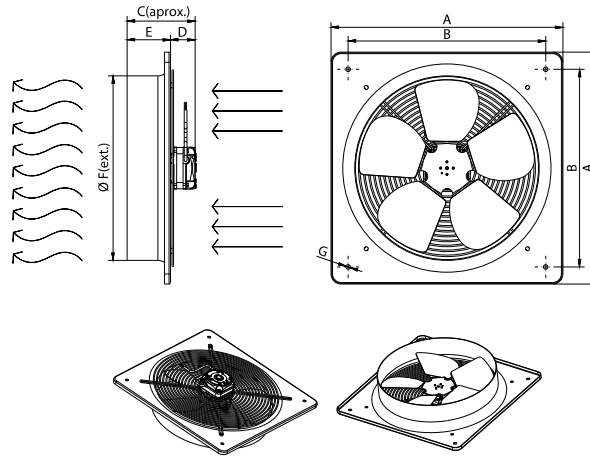

Dimensions (mm)									
A	312	B	262	C	97	D	49	E	48
ØF	201	ØG	7						

WIRING DIAGRAM

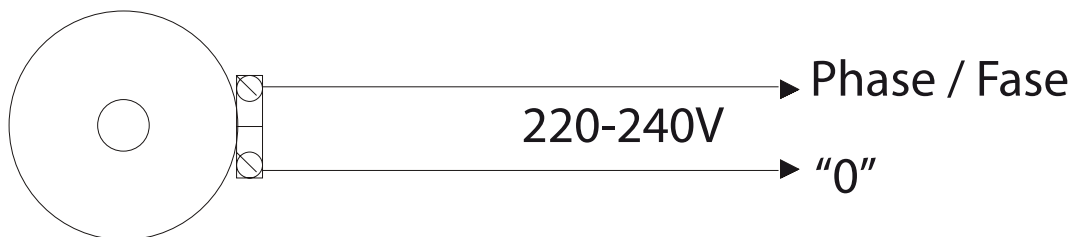

ACCESSORIES



MANUAL SINGLE PHASE SPEED CONTROLLER
REG 1,5A
REF: 960710015



SAFETY SWITCH
INT 25 3P A
REF: INT253PA



Outlet protection guard for axial fans
RP0 20
REF: 980000020



MANUAL SINGLE PHASE SPEED CONTROLLER
REGD-1
REF: 300782600

SPARE PARTS

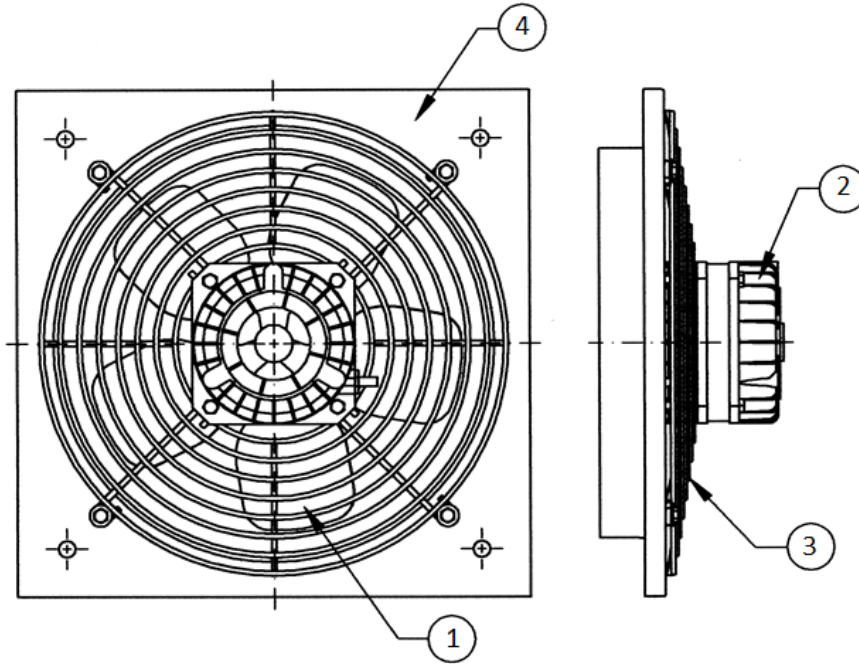

	Code	Model	Qty
1	R-265243671	IMPELLER HJEM20 170/26 ALUMINIO	x1
2	720001006	MOTOR 5W M4 230V (HJEM)	x1
3	R-265201905	PROTECTION GRID HJEM20	x1
4	R-265201778A001	FRAME HJEM20	x1