

# HJEM 30 M4 (265301103)

## GENERAL DATA



SQUARE WALL PLATE FAN

MANUFACTURING FEATURES

- Square plate made of galvanized steel sheet.
- Aluminium sheet impeller.
- Supplied with motor support and protection guard according to the UNE-EN 294 standard.
- Shaded-pole asynchronous motor, rated Class F isolation and IP-42.

APPLICATIONS

Designed for wall assembly, they are suitable for:

- Air renewal in all kind of closed environments.
- Maximum working temperature: 50°C.

## PERFORMANCE CURVE

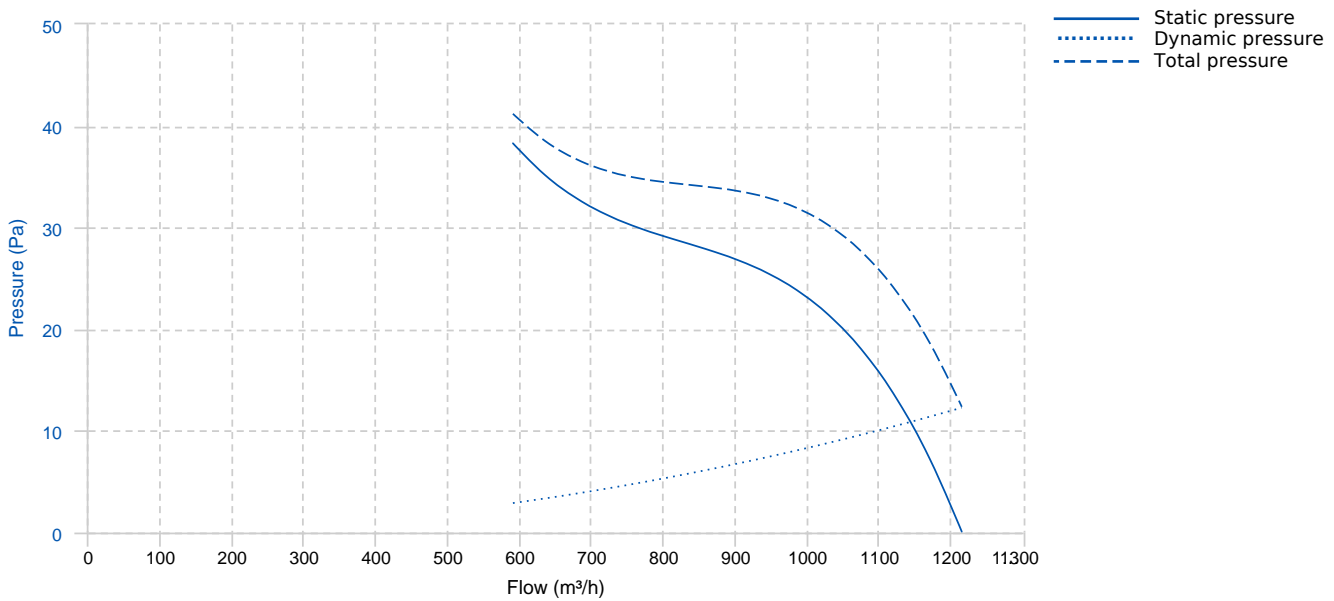

## TECHNICAL DATA

Fan					
RPM	1300	Approx. weight	3.5 kg	Max. Flow	1220 m³/h
Motor					
Power	0,025 kW	RPM	1300	I max. (230V)	0,7 A

## DIMENSIONS

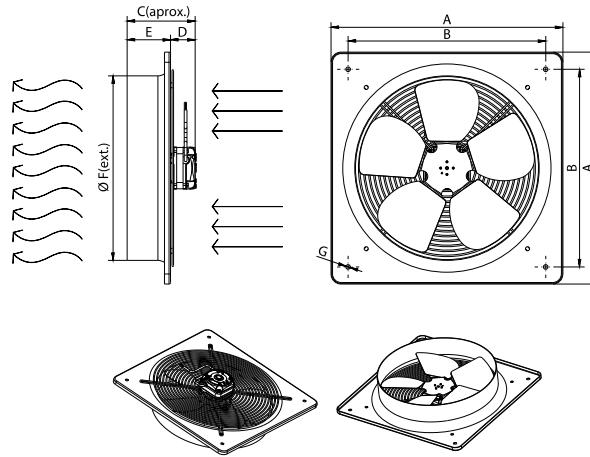

Dimensions (mm)									
A	404	B	337	C	156	D	74	E	82
ØF	308	ØG	9						

## WIRING DIAGRAM

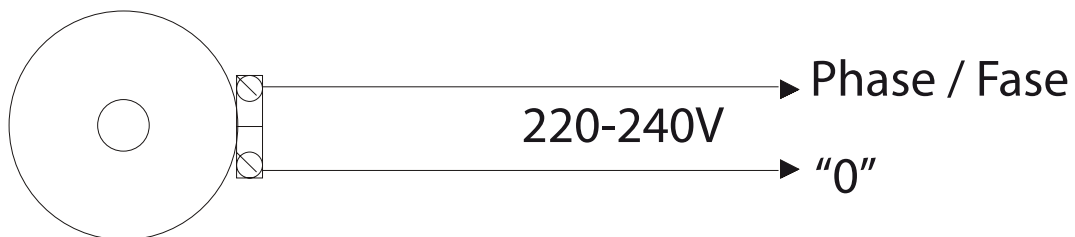

## ACCESSORIES



**MANUAL SINGLE PHASE SPEED CONTROLLER**  
**REG 1,5A**  
**REF: 960710015**



**SAFETY SWITCH**  
**INT 25 3P A**  
**REF: INT253PA**



**Outlet protection guard for axial fans**  
**RPO 30**  
**REF: 980000030**



**MANUAL SINGLE PHASE SPEED CONTROLLER**  
**REGD-1**  
**REF: 300782600**

**SPARE PARTS**

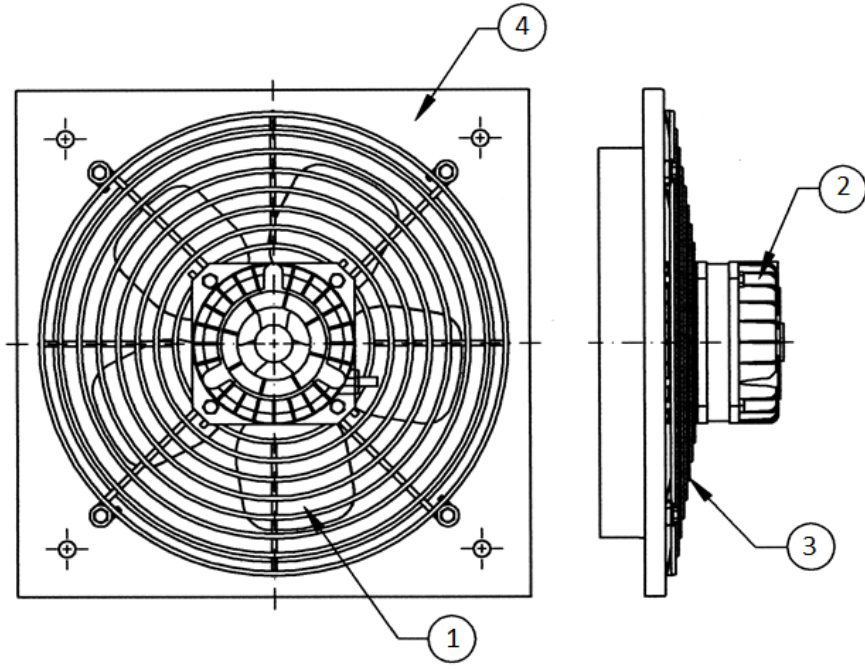

	Code	Model	Qty
1	R-265293650	IMPELLER HJEM30 300/20 ALUMINIO	x1
2	720001011	MOTOR 25,5W M4 230V (HJEM)	x1
3	R-265301905	PROTECTION GRID HJEM30	x1
4	R-265311778A001	FRAME HJEM-HJBM30	x1