

## MBP 20 T2 0,18kW (502202013)

### GENERAL DATA



#### MEDIUM PRESSURE WITH BACKWARD IMPELLER AND PLASTIC CONSTRUCTION

##### MANUFACTURING FEATURES:

- PE plastic housing.
- Backward impeller with self-cleaning system in PP plastic.
- Motor support made of rolled steel sheet with polyester powder finishing coat.
- Stainless steel nuts and bolts.
- Standard asynchronous squirrel-cage motor, IP-55, class F insulation. Standard voltages 230/400V 50Hz

- Available positions (to be indicated in case of order): LG270, LG0, LG45, LG90, LG135, LG180, LG225, LG315, RD0, RD45, RD90, RD135, RD180, RD225, RD270, RD315.
- The indicated codes correspond to the model in position LG270

##### APPLICATIONS:

Designed for inline installation, they are suitable for:

- Corrosive air transport.
- Chemical and petrochemical industry.
- Laboratories and gas cabinets.

- Maximum temperature of transported air: If it is clean air 70°C, other depends on the gas (see table in documentation)

##### UNDER REQUEST:

- Single phase motors (up to 1,1Kw).
- 60Hz fans and special voltages fans.
- 2 speed motors.
- Stainless steel motor support.
- Casing made of PP.

### PERFORMANCE CURVE

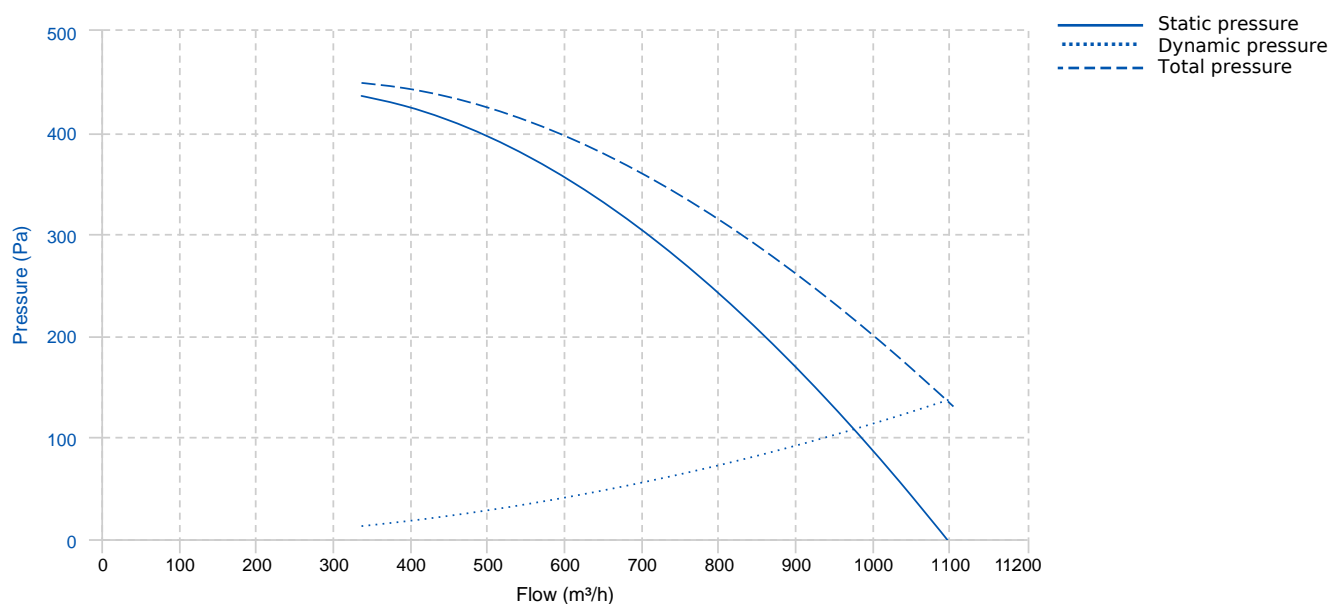

## TECHNICAL DATA

Fan							
RPM	2710	Approx. weight	9 kg	Max. Flow	1110 m <sup>3</sup> /h		
Motor							
Power	0.18 kW	RPM	2710	I max. (230V)	1 A	I max. (400V)	0,55 A
Size	63	Efficiency (%)	63 %	FP	0.75		

## DIMENSIONS

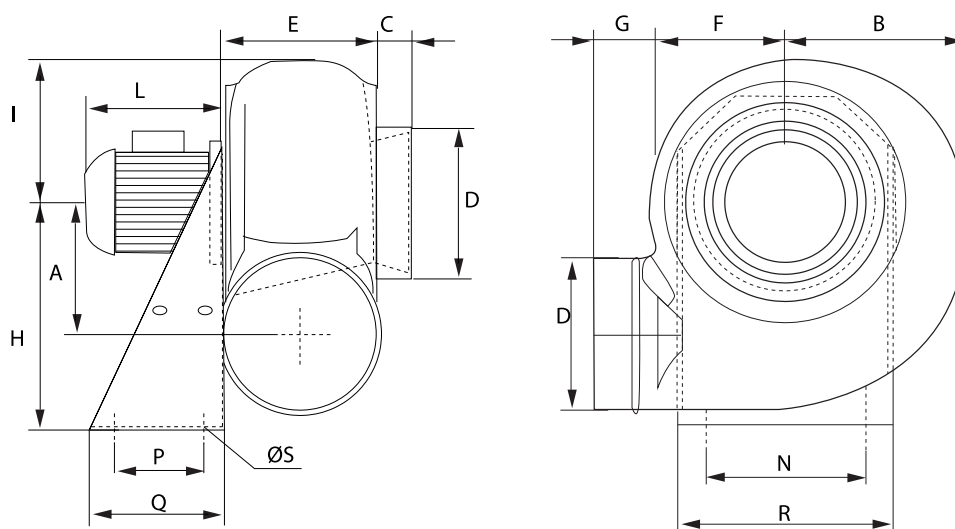

Dimensions (mm)									
A	140	B	180	C	35	DØ	160	E	160
F	138	G	55	H	250	I	150	L	195
N	200	P	100	Q	140	R	235	S	11

## WIRING DIAGRAM

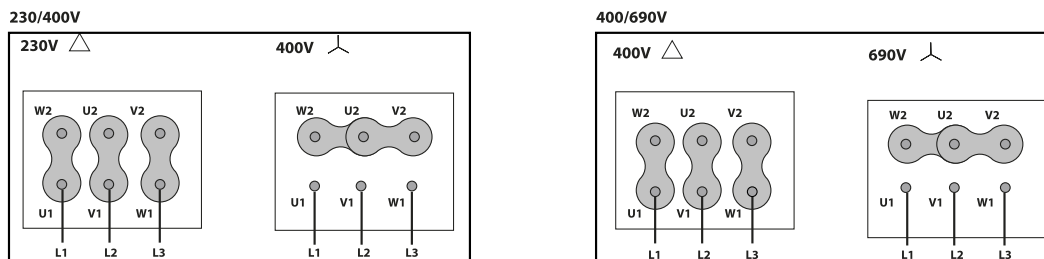

## ACCESSORIES



**SAFETY SWITCH**  
INT 25 3P A  
REF: INT253PA



**ANTI-VIBRATION JOINT**  
JE 45  
REF: 300719201



**DIFUSOR GRID**  
DG Ø160  
REF: DG160



**ADJUSTABLE DAMPER**  
AD Ø160  
REF: AD-160

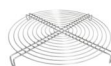

**STAINLESS STEEL PROTECTION GRID**  
RPI Ø160  
REF: RPI160



**ANTI-VIBRATION BLOCK**  
AV 1  
REF: AV-1



**MOTOR PROTECTION**  
PCM 1  
REF: PCM1



**ANTI-VIBRATING FLANGE 400<sup>º</sup>/2H**  
BA-400 15/16  
REF: 960002067



**PVC FLEXIBLE JOINT**  
FJ Ø160  
REF: FJ-160



**CIRCULAR GRAVITY DAMPER**  
CSC Ø160  
REF: CSC160



**DRAIN PLUG**  
PD 1  
REF: PD1



**WALL SUPPORT**  
WS 1  
REF: WS1



**CASING PROTECTION**  
PC 20  
REF: PC20



**FREQUENCY SPEED CONTROLLER**  
SFC 230 I 2,5A \*  
REF: SFC230I003



**FREQUENCY SPEED CONTROLLER  
SFC 400 III 1,2A \***  
REF: SFC400III1



**ANTI-VIBRATION RUBBER BLOCK  
AVR (GENERIC)**



**ANTI-VIBRATION SPRING BLOCK  
AVS (GENERIC)**

## SPARE PARTS

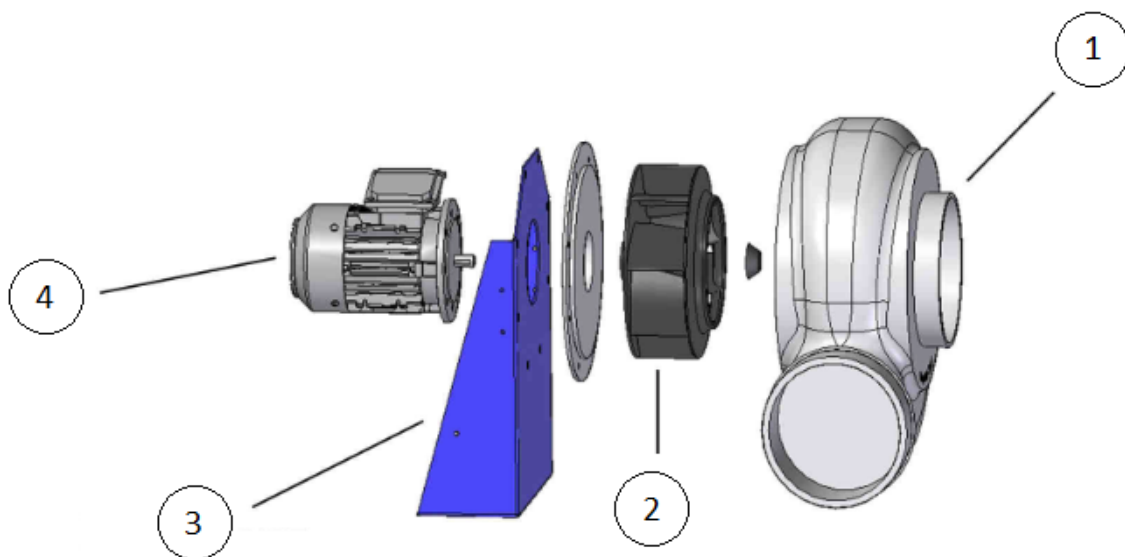

	Code	Model	Qty
2	T02202013	TURBINE MBP 20 T2 0,18kW LG	x1
4	721001013	MOTOR 0,18kW T2 B5 230/400V	x1