

SBC-3 315 EEC (SBC3315EC)

GENERAL DATA

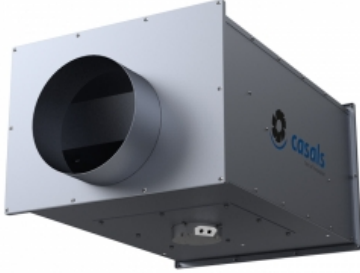

CENTRIFUGAL FAN IN LOW PROFILE BOX WITH CIRCULAR FLANGES, WITH EXTERNAL ROTOR EC MOTOR

MANUFACTURING FEATURES

Inline ventilation box made of galvanized steel with circular connection flanges. Self-cleaning impeller with back curved (backward) blades of high performance and single inlet, direct driven. Dynamically balanced to minimize noise and vibrations. Polyamide reinforced impeller for models 125, 150 and 160 and aluminum plate for the rest. High efficiency (IE4 for three phase motors and IE5 for single motors), low noise external rotor EC motor. Speed control through a 0-10V or PWM signal. Single-phase 230V 50/60Hz power supply for models 125 to 355 and three-phase 400V 50 / 60Hz for sizes 400 to 560. IP44 motor and class B insulation.

APPLICATIONS

Designed for duct installation, they are indicated for:

- Air renovations in bathrooms and small rooms.
 - Perfect for false ceiling installation.
- Working temperature range from -20°C to 60°C.

PERFORMANCE CURVE

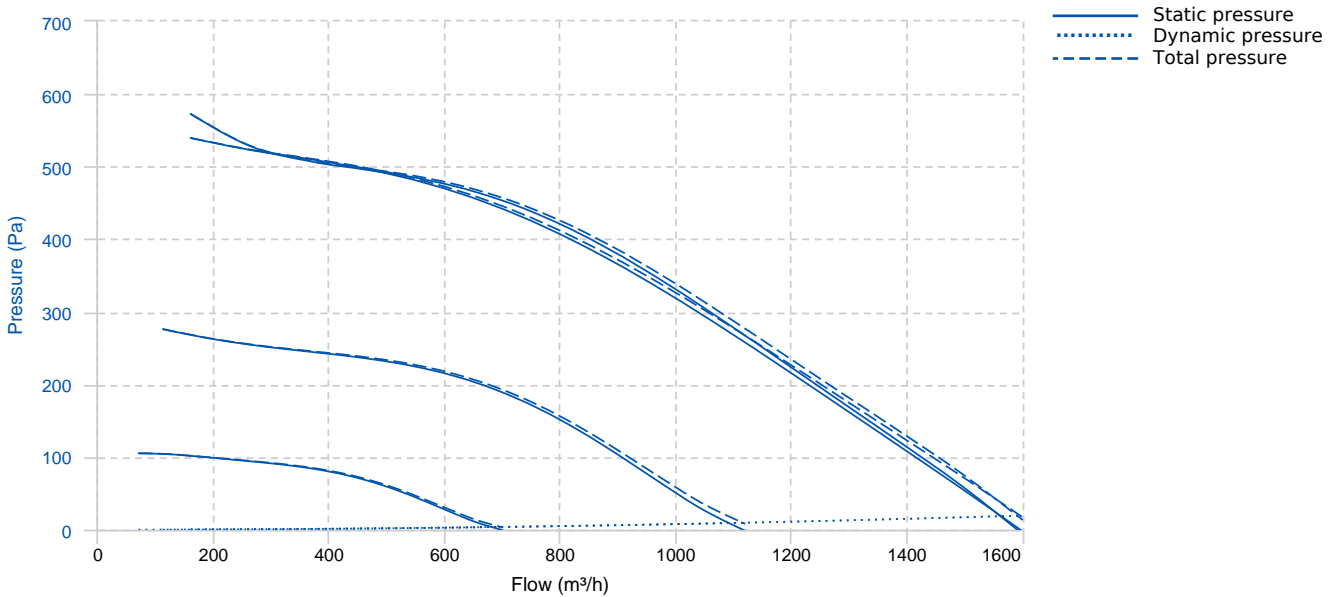

TECHNICAL DATA

Fan							
RPM	2500	Approx. weight	16 kg	Max. Flow	1600 m³/h		
Motor							
Power	0,145 kW	RPM	2500	I max. (230V)	1 A	Approx. weight	3.1 kg

ERP DATA

Fan data sheet		
Fan type	Unit for non-residential ventilation (LOT 6)	
Typology	Static	
reports.other	Outlet and Inlet free discharge	
Type of driver	None	
Motor power (kW)	0.145	
	Fan values	ERP Requirements 2018
Max. efficiency (%)	44.45	32.37
Effic. Heat recovery (%)	-	
Pabs (kW)	0.212	
Flow (m³/h)	898.58	
Static pressure (Pa)	379.98	
Speed (m/s)	3.2	
SFP (W/m3/s)	848.27	

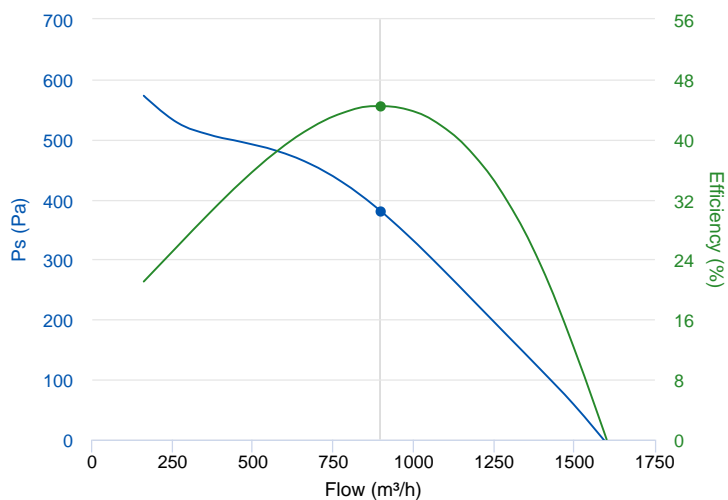

DIMENSIONS

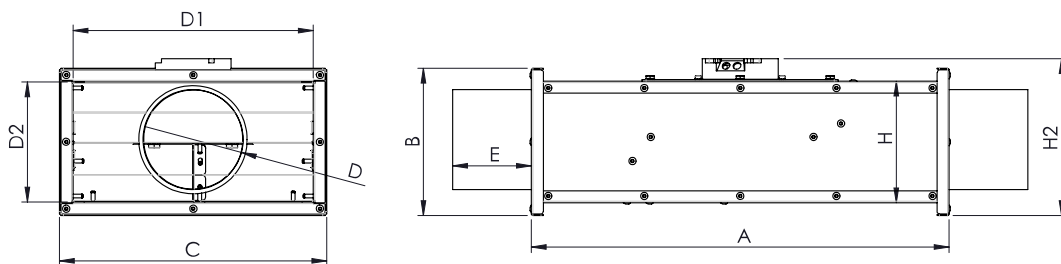

Dimensions (mm)									
A	752	B	387	C	534	D	315	D1	500
D2	353	E	98	H	357	H2	402.5		

WIRING DIAGRAM

Nº	Signal Señal	Colour Color	Specification Especificación
1	L	Brown Marrón	AC 220V/50Hz
2	N	Blue Azul	AC 220V/50Hz
3	Pe	Yellow-Green Amarillo-Verde	

Nº	Signal Señal	Colour Color	Specification Especificación
1	GND	Blue Azul	
2	Vsp	Yellow Amarillo	0-10 V/PWM
3	Vcc	Red Rojo	DC 10V
4	FG	White Blanco	1 Pulse/R

ACCESSORIES



**SAFETY SWITCH
INT 25 3P A**
REF: INT253PA



**SPEED CONTROLLER FOR EEC MOTOR
REGC**
REF: FX263300



**CIRCULAR OUTDOOR FLANGE WITH BIRD GUARD
VISC Ø315**
REF: FX0050065



**WEATHER PROTECTIVE ROOF FOR SB-3 EEC &
SBC-3 EEC & VARIANTS**
TEJ SB-3 5035
REF: TEJSB35035



**SPEED CONTROLLER WITH SAFETY SWITCH FOR
EEC MOTOR
PMR 25A**
REF: PMREEC

SPARE PARTS

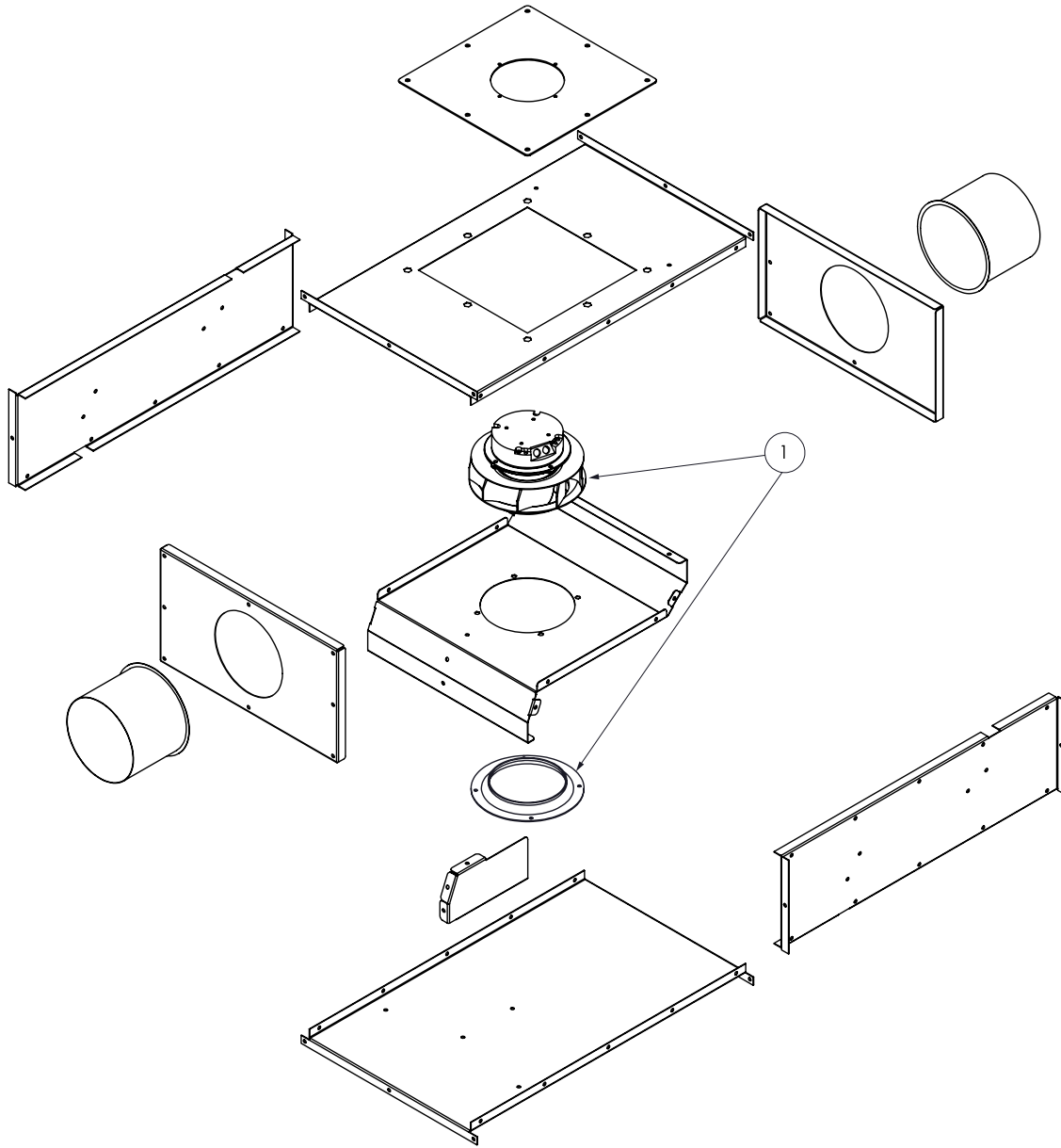

	Code	Model	Qty
1	R-241263017	MOTOR-FAN+INLET CONE Ø250 230V 50/60Hz	x1